

**GUAY**



**GROVE**  
worldwide



**RT700B** Series  
Rough-Terrain Hydraulic Crane Specifications

# Dimensions

# RT700B Series

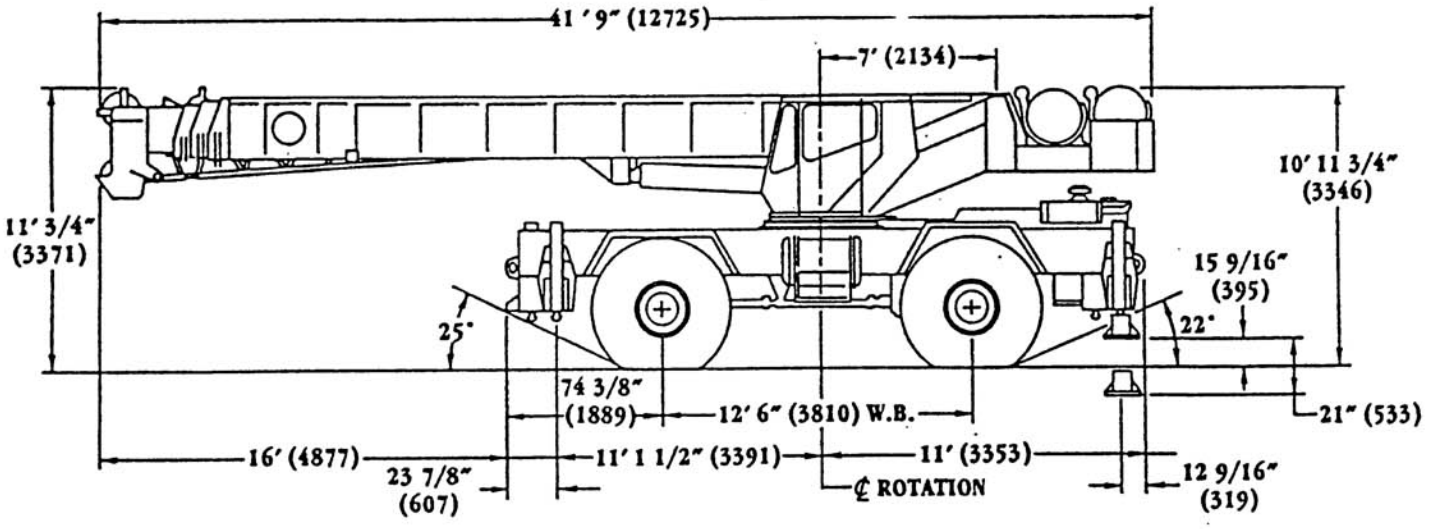
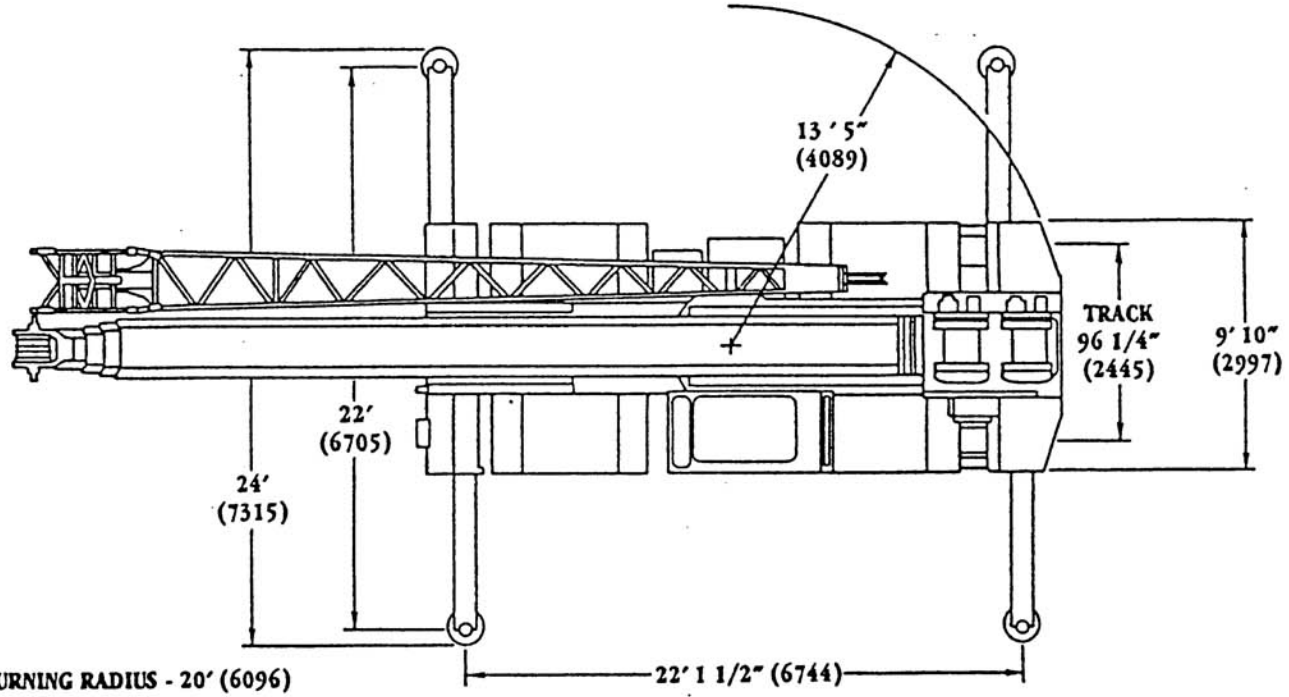



# RT740B

Rough terrain hydraulic crane/35 ft.-110 ft. full power boom

RANGE DIAGRAM (UNLADEN BOOM)

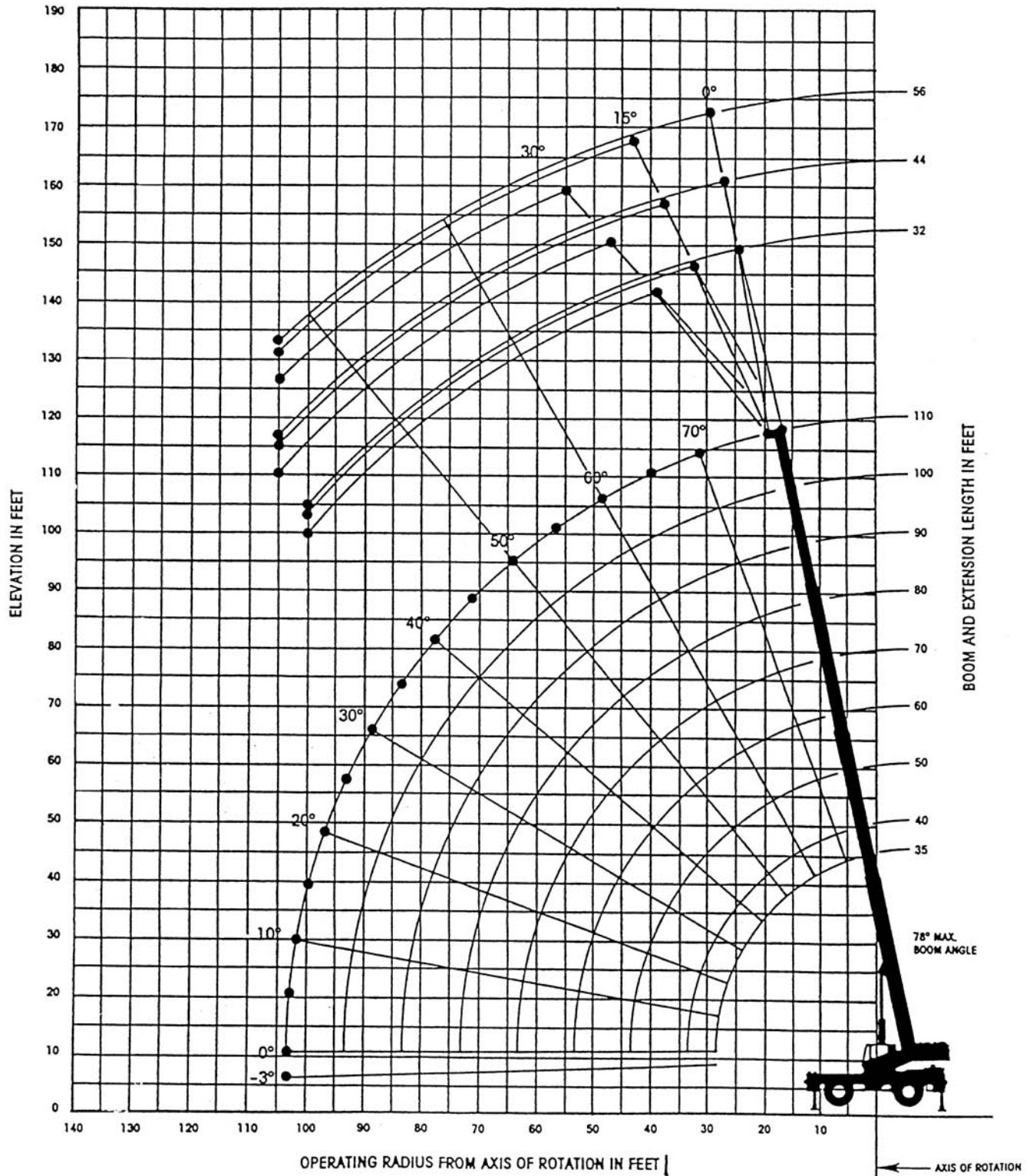

# NOTES FOR LIFTING CAPACITIES

"WARNING: THIS CHART IS ONLY A GUIDE. The Notes below are for illustration only and should not be relied upon to operate the crane. The individual crane's load chart, operating instructions and other instruction plates must be read and understood prior to operating the crane."

- All rated loads have been tested to and meet minimum requirements of SAE J1063 OCT80 - Cantilevered Boom Crane Structures - Method of Test, and do not exceed 85% of the tipping load on outriggers (75% of the tipping load on rubber) as determined by SAE J765 OCT80 Crane Stability Test Code.
- Capacities given do not include the weight of hookblocks, slings, auxiliary lifting equipment and load handling devices. Their weights MUST be added to the load to be lifted. When more than minimum required reeving is used, the additional rope weight shall be considered part of the load.
- Capacities appearing above the bold line are based on structural strength and tipping should not be relied upon as a capacity limitation.
- All capacities are for crane on firm, level surface. It may be necessary to have structural supports under the outrigger floats or tires to spread the load to a larger bearing surface.
- When either boom length or radius or both are between values listed, the smallest load shown at either the next larger radius or boom length shall be used.
- For outrigger operation, ALL outriggers shall be fully extended with tires raised free of ground before raising the boom or lifting loads.
- Tires shall be inflated to the recommended pressure before lifting on rubber.
- Unless otherwise stated, capacities are with powered boom sections equally extended.
- Defined Arc  $\pm 6^\circ$  on either side of longitudinal centerline of machine.
- With boom extension in working position and main boom length greater than 80 ft., boom angle must not be less than  $40^\circ$ , since loss of stability will occur causing a tipping condition.

## NOTES FOR RUBBER CAPACITIES

No Load Stability Data		Main Boom 110 ft.
Front (No load)	Min. boom angle (deg.) for indicated length	40
	Max. boom length (ft.) at 0 deg. boom angle	70
360 Deg. (No load)	Min. boom angle (deg.) for indicated length	55
	Max. boom length (ft.) at 0 deg. boom angle	50

## 23.5XR25 MICHELIN TIRES ON RUBBER (STATIONARY - DEFINED ARC OVER FRONT)

Radius in Feet	Main Boom Length in Feet							
	35	40	50	60	70	80	90	100
10	37,300 (66)	31,100 (69.5)	27,150 (74)					
12	32,700 (62)	28,750 (66)	20,000 (71.5)	18,300 (75)				
15	27,500 (56)	23,000 (61)	18,300 (67.5)	16,950 (71.5)	13,250 (74.5)	12,000 (77)		
20	21,550 (44.5)	20,750 (52)	16,950 (61)	13,500 (66.5)	11,400 (70.5)	10,300 (73.5)	9,050 (75.5)	7,350 (77.5)
25	16,950 (28.5)	16,950 (41.5)	13,600 (54)	11,300 (61)	10,250 (66)	9,250 (69.5)	8,050 (72)	6,500 (74.5)
30		11,850 (27)	11,400 (46)	10,000 (55)	9,300 (61)	8,500 (65.5)	7,350 (68.5)	5,900 (71.5)
35			8,220 (36.5)	7,910 (49)	8,430 (56)	7,800 (61.5)	6,850 (65)	5,600 (68)
40			5,910 (24)	5,440 (41.5)	5,980 (50.5)	5,980 (57)	5,980 (61.5)	5,300 (65)
45				4,030 (45)	4,170 (45)	4,170 (47.5)	4,170 (52.5)	4,170 (58.5)
50				2,760 (21.5)	2,770 (38.5)	2,770 (47.5)	2,770 (53.5)	2,770 (58.5)
55					1,840 (31)	1,840 (42)	1,840 (49.5)	1,840 (54.5)
60					1,290 (20)	1,290 (36)	1,290 (45)	1,290 (51)

A6-829-009205

## ON RUBBER (STATIONARY - 360°)

Radius in Feet	Main Boom Length in Feet							
	35	40	50	60	70	80	90	100
10	33,000 (66)	31,100 (69.5)	22,150 (74)					
12	27,350 (62)	26,750 (66)	19,000 (71.5)	18,300 (75)				
15	21,300 (56)	21,300 (61)	16,000 (67.5)	15,500 (71.5)	13,250 (74.5)	4,170 (77)		
20	13,150 (44.5)	12,750 (52)	12,400 (61)	12,400 (66.5)	10,300 (70.5)	4,170 (73.5)	4,500 (75.5)	2,050 (77.5)
25	8,630 (28.5)	8,230 (41.5)	7,840 (54)	7,790 (61)	7,650 (66)	4,170 (69.5)	4,500 (72)	2,050 (74.5)
30		5,410 (27)	5,000 (46)	4,870 (55)	5,410 (61)	5,200 (65.5)	4,500 (68.5)	2,050 (71.5)
35			3,100 (36.5)	2,870 (49)	3,380 (56)	3,380 (61.5)	3,120 (65)	2,050 (68)
40			1,650 (24)	1,430 (41.5)	1,750 (50.5)	1,750 (57)	1,710 (61.5)	1,710 (65)

A6-829-009206

## ON RUBBER (PICK & CARRY - BOOM CENTERED OVER FRONT)

Radius in Feet	Main Boom Length in Feet							
	35	40	50	60	70	80	90	
10	38,000 (66)	31,450 (69.5)	30,000 (74)					
12	33,150 (62)	29,000 (66)	27,750 (71.5)	26,750 (75)				
15	27,300 (56)	27,300 (61)	25,000 (67.5)	22,750 (71.5)	17,300 (74.5)	14,500 (77)		
20	20,750 (44.5)	20,750 (52)	20,450 (61)	17,300 (66.5)	13,750 (70.5)	12,500 (73.5)	11,500 (75.5)	
25	15,950 (28.5)	15,850 (41.5)	15,850 (54)	13,400 (61)	11,000 (66)	11,000 (69.5)	10,150 (72)	
30		11,850 (27)	11,500 (46)	10,600 (55)	9,300 (61)	9,300 (65.5)	9,300 (68.5)	
35			8,220 (36.5)	7,910 (49)	8,200 (56)	8,200 (61.5)	8,200 (65)	
40			5,910 (24)	5,680 (41.5)	5,980 (50.5)	5,980 (57)	5,980 (61.5)	
45				4,030 (33)	4,170 (45)	4,170 (52.5)	4,170 (57.5)	
50				2,760 (21.5)	2,770 (38.5)	2,770 (47.5)	2,770 (53.5)	
55					1,840 (31)	1,840 (42)	1,840 (49.5)	
60					1,290 (20)	1,290 (36)	1,290 (45)	

A6-829-009207

Note: ( ) Boom angles are in degrees.

\*60 ft. boom length is with inner-mid extended and outer-mid & B retracted.

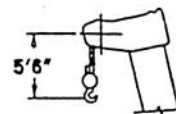

DIMENSIONS ARE FOR LARGEST GROVE FURNISHED HOOK BLOCK AND HEADACHE BALL WITH ANTI-TWO BLOCK ACTIVATED.

### 32 FT. OFFSETTABLE EXTENSION ON OUTRIGGERS - 360°

Radius In Feet	0° OFFSET		15° OFFSET		30° OFFSET	
	Boom Ang. (Deg.)	Cap. lbs.	Boom Ang. (Deg.)	Cap. lbs.	Boom Ang. (Deg.)	Cap. lbs.
30	78.0	8,880				
35	75.5	8,480	78.0	7,380		
40	73.5	7,980	75.5	6,980	78.0	6,180
45	71.5	7,480	73.5	6,580	76.0	5,850
50	69.0	6,980	71.5	6,180	73.5	5,340
55	67.0	6,430	69.0	5,800	71.5	4,980
60	64.5	5,880	67.0	5,450	69.0	4,780
65	62.0	5,240	64.5	5,110	67.0	4,620
70	59.5	4,650	62.0	4,650	64.5	4,470
75	57.0	4,120	59.5	4,120	62.0	4,120
80	54.5	3,640	57.0	3,640	59.5	3,640
85	52.0	2,960	54.5	2,960	57.0	2,960
90	49.0	2,370	52.0	2,370	54.0	2,370
95	46.5	1,850	49.0	1,850	51.0	1,850
100	43.5	1,380	46.0	1,380	48.0	1,380

\*This capacity is based upon the maximum boom angle. A6-829-008842

### WEIGHT REDUCTIONS FOR LOAD HANDLING DEVICES

32' OFFSETTABLE	
↓ Slowed -	671 lbs.
↑ Erected -	4,149 lbs.

32'-56' TELE OFFSETTABLE BOOM EXTENSION	
↓ Slowed -	846 lbs.
↑ Erected (Retracted) -	6,368 lbs.
↑ Erected (Extended) -	8,287 lbs.

↑Reduction of main boom capacities.

HOOKBLOCKS:	
45 Ton, 3 Sheave .....	1,095 lbs.
15 Ton, 1 Sheave .....	380 lbs.
Auxiliary Boom Head .....	143 lbs.
10 Ton Headache Ball .....	560 lbs.
7 1/2 Ton Headache Ball .....	338 lbs.

### 35 FT. - 110 FT. FULL POWER BOOM ON OUTRIGGERS FULLY EXTENDED - 360°

Radius in Feet	Main Boom Length in Feet									
	35	40	50	60	70	80	90	100	110	
10	80,000 (66)	68,000 (69.5)	58,100 (74)							
12	67,400 (62)	62,700 (66)	53,700 (71.5)	44,600 (75)						
15	56,500 (56)	54,500 (61)	48,050 (67.5)	41,550 (71.5)	35,600 (74.5)	33,000 (77)				
20	44,000 (44.5)	43,000 (52)	39,400 (61)	33,550 (66.5)	30,500 (70.5)	28,000 (73.5)	25,500 (75.5)	22,150 (77.5)		
25	33,500 (28.5)	33,000 (41.5)	32,400 (54)	27,750 (61)	25,200 (66)	23,800 (69.5)	21,950 (72)	20,400 (74.5)	18,500 (76)	
30		26,500 (27)	25,500 (46)	23,300 (55)	21,050 (61)	20,400 (65.5)	19,300 (68.5)	17,550 (71.5)	15,750 (73.5)	
35			20,300 (36.5)	20,000 (49)	17,950 (56)	17,400 (61.5)	16,400 (65)	15,050 (68)	13,650 (70.5)	
40			16,000 (24)	15,850 (41.5)	15,500 (50.5)	15,050 (57)	14,100 (61.5)	13,100 (65)	12,000 (68)	
45				12,250 (33)	13,000 (45)	13,000 (52.5)	12,300 (57.5)	11,450 (61.5)	10,600 (65)	
50				9,720 (21.5)	10,350 (33)	10,750 (47.5)	10,800 (53.5)	10,000 (58.5)	9,500 (62)	
55					8,300 (31)	8,770 (42)	9,170 (49.5)	8,830 (54.5)	8,370 (58.5)	
60					6,650 (20)	7,150 (36)	7,850 (45)	7,840 (51)	7,410 (55.5)	
65						5,830 (29)	6,340 (40)	6,820 (47)	6,590 (52)	
70						4,740 (19)	5,100 (34)	5,590 (42.5)	5,880 (48.5)	
75							4,050 (27.5)	4,540 (38)	4,980 (45)	
80							3,160 (18)	3,650 (32.5)	4,120 (40.5)	
85								2,870 (26)	3,380 (36)	
90								2,190 (17)	2,740 (31)	
95									2,170 (25)	
100									1,790 (16)	
Minimum boom angle (deg.) for indicated length (no load)										0
Maximum boom length (ft.) at 0 deg. boom angle (no load)										110

Note: ( ) Boom angles are in degrees.

A6-829-008824A

\*60 ft. boom length is with inner-mid extended and outer-mid & fly retracted.

### 32 FT. - 56 FT. TELE OFFSETTABLE EXTENSION (ON OUTRIGGER - 360°)

Radius in Feet	32 ft. LENGTH						44 ft. LENGTH						56 ft. LENGTH						
	0° OFFSET		15° OFFSET		30° OFFSET		0° OFFSET		15° OFFSET		30° OFFSET		0° OFFSET		15° OFFSET		30° OFFSET		
	Boom Angle Ref. (Deg.)	Cap. lbs.	Boom Angle Ref. (Deg.)	Cap. lbs.	Boom Angle Ref. (Deg.)	Cap. lbs.	Boom Angle Ref. (Deg.)	Cap. lbs.	Boom Angle Ref. (Deg.)	Cap. lbs.	Boom Angle Ref. (Deg.)	Cap. lbs.	Boom Angle Ref. (Deg.)	Cap. lbs.	Boom Angle Ref. (Deg.)	Cap. lbs.	Boom Angle Ref. (Deg.)	Cap. lbs.	
30	78.0	8,500					78.0	5,100											
35	75.5	8,100	78.0	7,000			76.5	5,060											
40	73.5	7,600	75.5	6,600	78.0	5,800	74.5	5,000					76.5	4,000					
45	71.5	7,100	73.5	6,200	76.0	5,470	73.0	4,900	76.5	4,300			74.5	3,920					
50	69.0	6,800	71.5	5,800	73.5	4,960	71.0	4,750	74.5	4,110	77.5	3,300	73.0	3,840	77.0	3,300			
55	67.0	6,050	69.0	5,420	71.5	4,600	68.5	4,550	72.5	3,920	75.0	3,200	71.0	3,770	75.0	3,100			
60	64.5	5,500	67.0	5,070	69.0	4,400	66.5	4,300	70.5	3,750	73.0	3,100	69.5	3,700	73.5	2,920	77.5	2,300	
65	62.0	4,860	64.5	4,730	67.0	4,240	64.5	4,010	68.5	3,570	71.0	3,000	67.5	3,610	71.5	2,760	75.5	2,200	
70	59.5	4,270	62.0	4,270	64.5	4,090	62.5	3,710	66.5	3,400	69.0	2,900	65.5	3,500	69.5	2,620	73.5	2,100	
75	57.0	3,740	59.5	3,740	62.0	3,740	60.5	3,400	64.0	3,200	66.5	2,800	64.0	3,310	68.0	2,500	71.5	2,020	
80	54.5	3,260	57.0	3,260	59.5	3,260	58.0	3,090	62.0	3,000	64.5	2,700	62.0	3,000	66.0	2,400	69.5	1,950	
85	52.0	2,580	54.5	2,580	57.0	2,580	56.0	2,790	60.0	2,790	62.0	2,600	60.0	2,510	64.0	2,300	67.5	1,880	
90	49.0	1,990	52.0	1,990	54.0	1,990	53.5	2,500	57.5	2,500	59.5	2,500	58.0	2,020	61.5	2,020	65.5	1,810	
95	46.5	1,470	49.0	1,470	51.0	1,470	51.0	1,990	55.0	1,990	57.0	1,990	56.0	1,660	59.5	1,660	63.0	1,660	
100	43.5	1,000	46.0	1,000	48.0	1,000	48.5	1,520	52.5	1,520	54.5	1,520	53.5	1,230	57.5	1,230	61.0	1,230	
105							46.0	1,100	50.0	1,100	51.5	1,100	51.5	850	55.0	850	58.5	850	

\*This capacity is based upon maximum boom angle.

A6-829-008841