



GROVE

GMK5165-2

preliminary product guide

features

- 165 USt (130 t) capacity
- 42-197 ft (12.9-60 m) 6-section full power boom
- 36-59 ft (11-18 m) bifold lattice swingaway, hydraulic luffing or manual offset
- 12 ft (3.6 m) 3-sheave heavy duty jib, hydraulic luffing integrated in swingaway
- 88,400 lb (40 100 kg) counterweight with hydraulic removal system
- 510 hp (380 kW) Mercedes OM 502 LA 8 cylinder turbo-charged diesel engine. Daimler Chrysler, 16 speed G240-16 transmission
- Patented TWIN-LOCK™ boom pinning system
- Independent hydro-pneumatic MEGATRAK™ suspension
- All wheel steering

contents

Features	2
Specifications	3
Dimensions	5
Counterweight Dimensions	6
Travel Proposal	7
Working Range Main Boom	8
Main Boom Charts	9
Load Charts	10
Working Range Manual Offset Swingaway	11
Working Range Hydraulic Offset Swingaway	12
Hydraulic Offset Swingaway Charts	13
Manual Offset Swingaway Charts	14



All Terrain Crane

features

2



Mercedes-Benz OM 502 LA
510 bhp (380 kW) @ 1800 rpm
1770 ft./lb. torque (2400 Nm) @ 1200 rpm

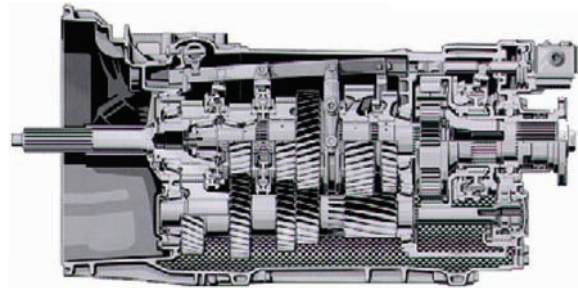

Daimler Chrysler
16 speed G240-16

TWIN-LOCK™

Boom pinning mechanism automatically pins the sections in position using two horizontal large diameter boom pins. The proven "U"-shaped MEGAFORM™ design provides a natural cradling position for boom sections which eliminates stiffeners, reducing weight and increasing capacity. Large wear pads provide superior boom alignment when telescoping and allows an excellent transition of weights between sections.

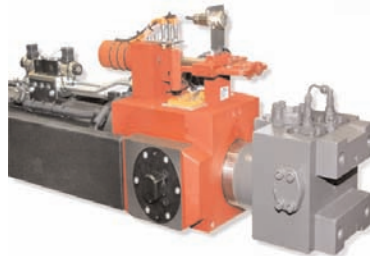

LUFFING BI-FOLD SWINGAWAY

Hydraulically offset lattice bi-fold swingaway lets the operator set the offset from 0°-40° while under load, from the superstructure cab; 12 ft (3.6 m) 3-sheave heavy duty jib, hydraulic luffing integrated in swingaway.



MEGATRAK™

Independent suspension and all wheel steer system allows wheels to remain on the ground at all times so stresses and weight are not continually transferred between axles.

GMK5165-2

specifications

3

Superstructure

Boom

42 ft. - 197 ft. (12.9 m - 60 m) six section, full power boom with patented TWIN-LOCK™ boom pinning system. Maximum tip height: 207 ft. (63 m).

Boom Nose

Eight nylatron sheaves, mounted on heavy duty tapered roller bearings with removable pin-type rope guards. Quick reeve boom nose. Removable auxiliary boom nose with removable pin type rope guard.

Boom Elevation

Single lift cylinder with safety valve provides boom angle from -3° to +83°.

Hydraulically Offsettable Lattice Extension

36 ft. - 59 ft. (11 m - 18 m) bifold lattice swingaway extension **hydraulically offsettable** and luffing under load: 0° - 40°. Controlled from the crane cab. Maximum tip height: 266 ft. (81 m)

*Offsettable Lattice Extension

36 ft. - 59 ft. (11 m - 18 m) bifold lattice swingaway extension manually offset: 0°, 20° or 40°. Maximum tip height: 266 ft. (81 m)

Lattice Extension Inserts

One 26 ft. (8 m) and one 20 ft. (6 m) insert for use with lattice swingaway extension. Increases extension length to 85 ft. (26 m) or 105 ft. (32 m).

Load Moment & Anti-Two Block System

Load moment and anti-two block system with audio/visual warning and control lever lockout provides electronic display of boom angle, length, radius, tip height, relative load moment, maximum permissible load, load indication and warning of impending two-block condition.

Cab

All aluminum construction cab with acoustical lining, tinted safety glass, adjustable operator's seat with suspension, opening windows in side and cab rear, hinged front window with wiper, sunvisor and window shade. Other features include hot water heater, armrest integrated crane controls, and ergonomically arranged instrumentation.

Crane Control System

Full electronic control of all crane movements using electrical control levers with automatic reset to zero. Controls are integrated with the LMI and engine management system by CAN-BUS. ECOS system with graphic display.

Swing

Two planetary gears with axial piston motors. Infinitely variable to 1.7 rpm. Holding and service brake.

Counterweight

88,400 lbs. (40 100 kg) consisting of various sections with hydraulic installation/removal system. Controlled from the superstructure cab.

Engine

Mercedes-Benz OM 904 LA diesel, 4 cylinders, water cooled, turbocharged with 174 bhp (130 kW) @ 2200 rpm. Max torque: 498 ft/lb. (675 Nm) at 100 rpm. Engine emission: EUROMOT/EPA/CARB (non road).

Hydraulic System

2 separate circuits, 1 axial piston variable displacement pump (load sensing) with electronic power limiting control and 1 gear pump for swing. Dual thermostatically controlled oil coolers keep oil at optimum operating temperature. Tank capacity: 221 gal. (840 l)

Hoist

Main and auxiliary hoists are powered by axial piston motor with planetary gear and brake. "Thumb-thumper" hoist drum rotation indicator alerts operator of hoist movement.

	Main	Auxiliary
Line length:	837 ft. (255 m)	591 ft. (180 m)
Rope diameter:	19 mm	19 mm
Line speed:	394 ft./min. (120 m/min)	394 ft./min. (120 m/min)
Line pull:	15,700 lbs. (70 kN)	15,700 lbs. (70 kN)

Electrical System

24V system with three phase alternator, 28V/80A. 2 batteries, 12V/170 Ah.

*Optional Equipment

- *11.8 ft (3.6 m) side-stowed 3-sheave heavy-duty jib integrated in swingaway.
- *Work light, mounted on top of base section.
- *Cab controlled work lights mounted to top of base section.
- *Stainless steel exhaust system with spark arrestor in lieu of standard.
- *Engine independent diesel cab heater, also serves as engine preheater including 24-hour timer.
- *Engine independent propane gas cab heater.
- *Stereo/radio CD player.
- *Outrigger pad load indicator with readout both in superstructure cab and carrier.
- *Air conditioning.
- *Working range limiter.
- *Boom mounted aircraft warning light.
- *Drive and steer control for superstructure.
- *EKS5 with full graphic display.

*Denotes optional equipment

GMK5165-2

GROVE

specifications

4

Carrier



Chassis

Box type, torsion resistant frame is fabricated from high strength steel.



Outrigger System

Four hydraulic single stage outrigger beams with vertical cylinders and outrigger pads, 23.6" (600 mm) square. Outriggers can be set in 3 positions:

Full	- 24.6' (7.5 m)
Partial	- 22.0' (6.7 m)
	- 19.4' (5.9 m)
	- 16.7' (5.1 m)
Retracted	- 8.2' (2.5 m)

Independent horizontal and vertical movement controlled from each side of carrier. Electronic crane level indicators.



Engine

Mercedes-Benz OM 502 LA eight cylinder, water cooled, turbo-charged, with 510 bhp (380 kW) @ 1800 rpm. Max. torque 1,770 ft./lb. (2 400 Nm) @ 1200 rpm.

Engine emissions: EUROMOT/EPA/CARB (off road)
Compression and exhaust brakes.



Fuel Tank Capacity

106 gallons (400 L).



Transmission

Daimler Chrysler, 16 speed G240-16.



Drive/Steer

10X6X10



Axles

1st axle line – steer

2nd axle line – steer (additional drive)

3rd axle line – drive/steer (disconnects for highway travel
10x8x10 drive only)

4th axle line – drive/steer (connects for all wheel steer)

5th axle line – drive/steer

Drive axles with planetary hub reduction and center mounted differential-gearing. Inter-axle and cross axle differential locks.



Suspension

Exclusive MEGATRAK suspension. Independent hydro-pneumatic system acting on all wheels with hydraulic lockout. Suspension can be raised 6.5" (170 mm) or lowered 5" (130 mm) both longitudinally and transversely. Features an automatic leveling system for highway travel.



Tires

10 tires, 16.00R25



Steering

Dual circuit, hydraulic power assisted steering system. Transfer case mounted, ground driven emergency steering pump. Axles 1, 2, 3 and 5 steer on highway. Separate steering of the 4th and 5th axles for all wheel and crab steering, controlled by an electronic rocker switch.



Brakes

Service brakes: pneumatic dual circuit acting on all wheels, anti lock prevention.

Parking brake: pneumatically operated spring loaded brake acting on axle lines 2 and 5.

Air dryer.



Cab

Two-man construction with the following features: safety glass, driver and passenger seats with suspension, heated rear view mirrors, engine independent diesel cab heater, AC, complete instrumentation and driving controls.



Electrical System

24V system with three phase alternator, 28V/100A
2 batteries, 12V/170 Ah



Maximum Speed

53 mph (85 kph)



Gradeability (Theoretical)

72% - 14.00 tires

64% - 16.00/20.5 tires

Miscellaneous Standard Equipment

Work light; tool kit; fire extinguisher; auxiliary boom nose; radio/CD player in carrier cab, heated rear view mirrors, and cruise control.

Optional Equipment

*Stainless steel exhaust system with spark arrestor

*20.5R25 tires (vehicle width 10.2 ft., 3.1 m)

*10X8X10 drive/steer

*Electric driveline retarder

*Worklights for outriggers

*Steel outrigger floats

*Spare tire with carry bracket

*Outrigger pad load indicator

*Hinged bunk bed

*Denotes optional equipment

GMK5165-2

GROVE

dimensions

5

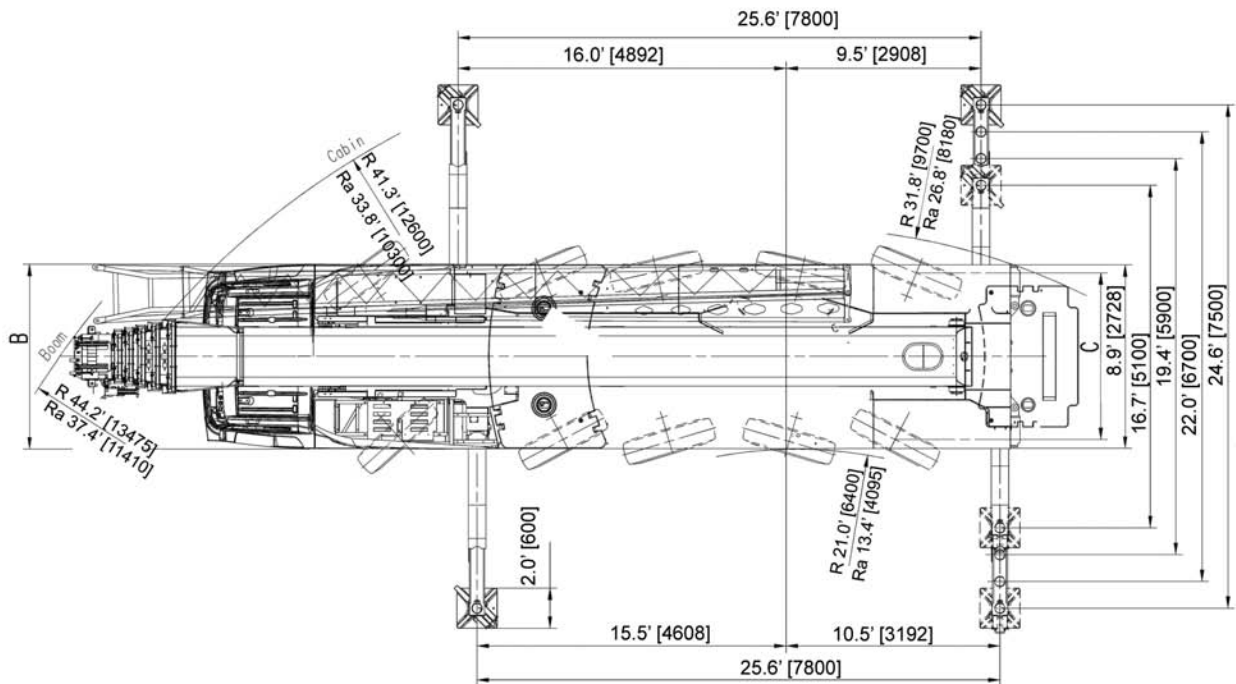
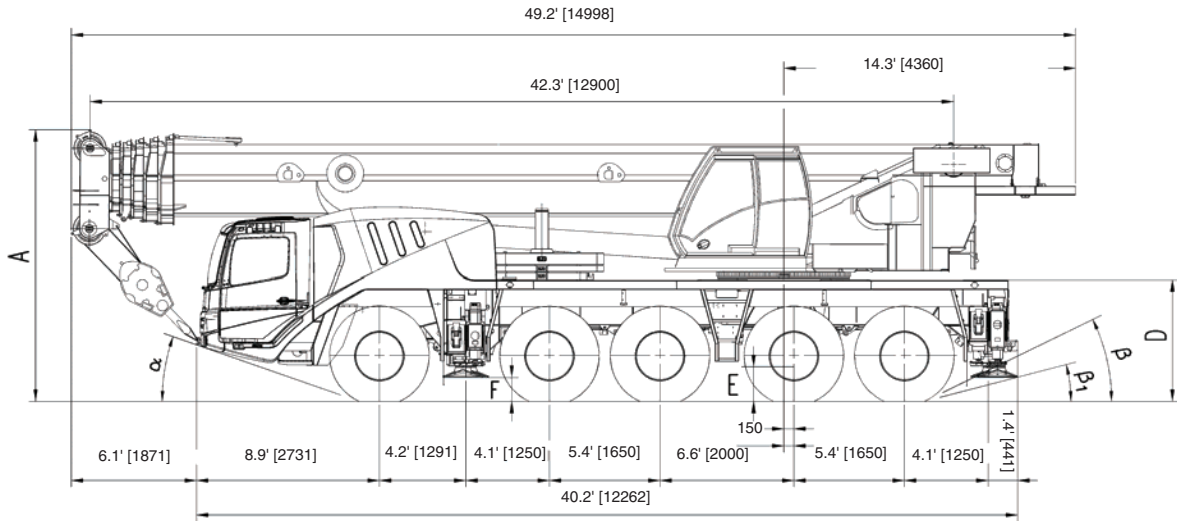

	A	A 5.1 in.* (130mm)	B	C	D	E	F	α	β	β1
14.00 R25	12.9 (3945)	12.5 (3815)	9.0 (2750)	7.7 (2338)	5.7 (1750)	1.4 (435)	1.2 (356)	18°	23°	17°
16.00 R25	13.1 (3995)	12.7 (3865)	9.8 (3000)	8.2 (2486)	5.9 (1800)	1.6 (485)	1.3 (386)	20°	25°	19°
20.5 R25	13.1 (3995)	12.7 (3865)	9.8 (3000)	8.2 (2507)	5.9 (1800)	1.6 (485)	1.3 (386)	20°	25°	19°

Ra = Radius all wheels steered
*Lowered

GMK5165-2

counterweight

6

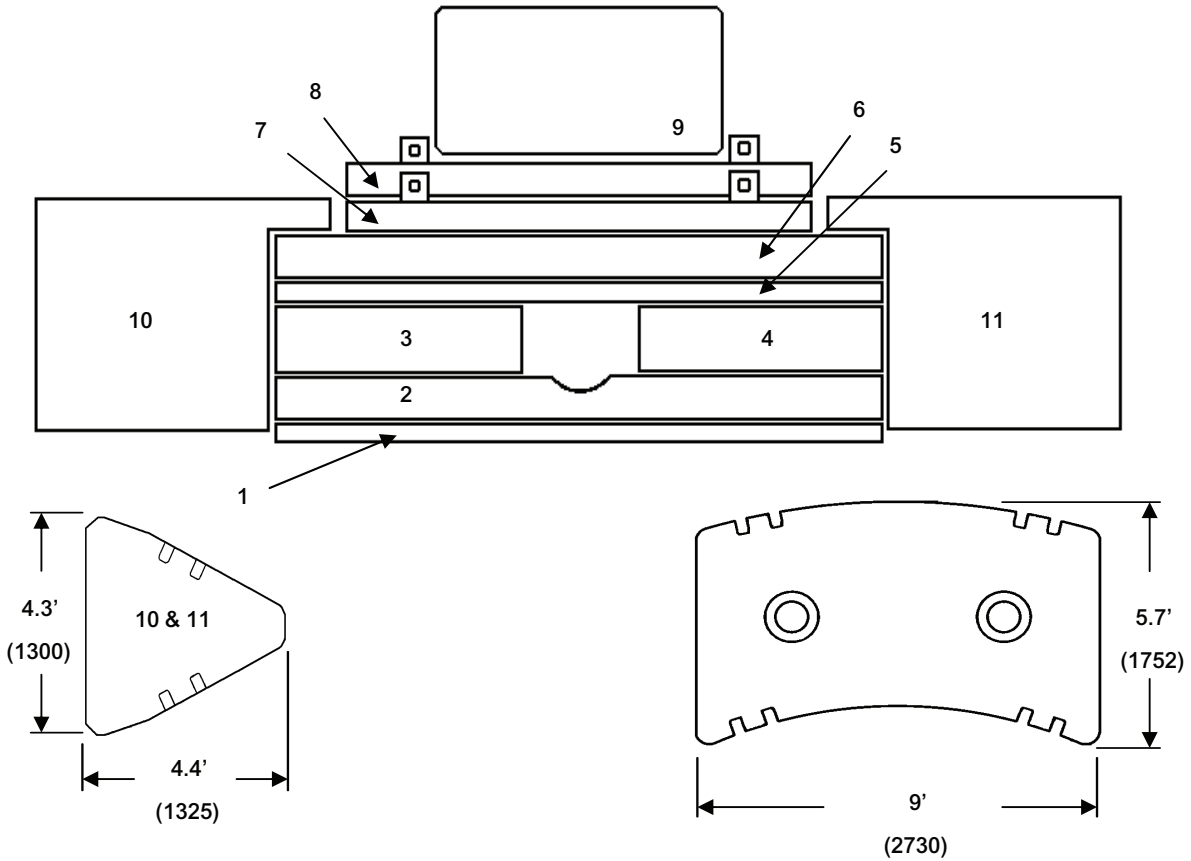

(2730)

- | | |
|-----------------------------------|---|
| 1. 5,500 lb.(2 500 kg.) Baseplate | 7. 5,500 lb.(2 500 kg.) Pinned |
| 2. 11,000 lb.(5 000 kg.) Stacking | 8. 5,500 lb.(2 500 kg.) Pinned |
| 3. 8 300 lb.(3 750 kg.) Stacking | 9. 2,200 lb.(1 000 kg.) Bolted (Auxiliary Hoist or IPO) |
| 4. 8,300 lb.(3 750 kg.) Stacking | 10. 12,700 lb.(5 770 kg.) Wing |
| 5. 5,500 lb.(2 500 kg.) Stacking | 11. 12,700 lb.(5 770 kg.) Wing |
| 6. 11,000 lb.(5 000 kg.) Stacking | |

Counterweight Configuration lb.(kg.)	1	2	3	4	5	6	7	8	9	10	11
2,200 (1 000)									•		
7,700 (3 500)								•	•		
13,200 (6 000)							•	•	•		
18,700 (8 500)	•						•	•	•		
24,200 (11 000)	•		•	•					•		
29,700 (13 500)	•		•	•				•	•		
35,200 (16 000)	•		•	•			•	•	•		
40,700 (18 500)	•	•	•	•				•	•		
46,200 (21 000)	•	•	•	•			•	•	•		
51,800 (23 500)	•	•	•	•	•		•	•	•		
57,300 (26 000)	•	•	•	•		•	•	•	•		
62,800 (28 500)	•	•	•	•	•	•	•	•	•		
88,400 (40 100)	•	•	•	•	•	•	•	•	•	•	•

GMK5165-2

weight proposals

7

Trailing Boom

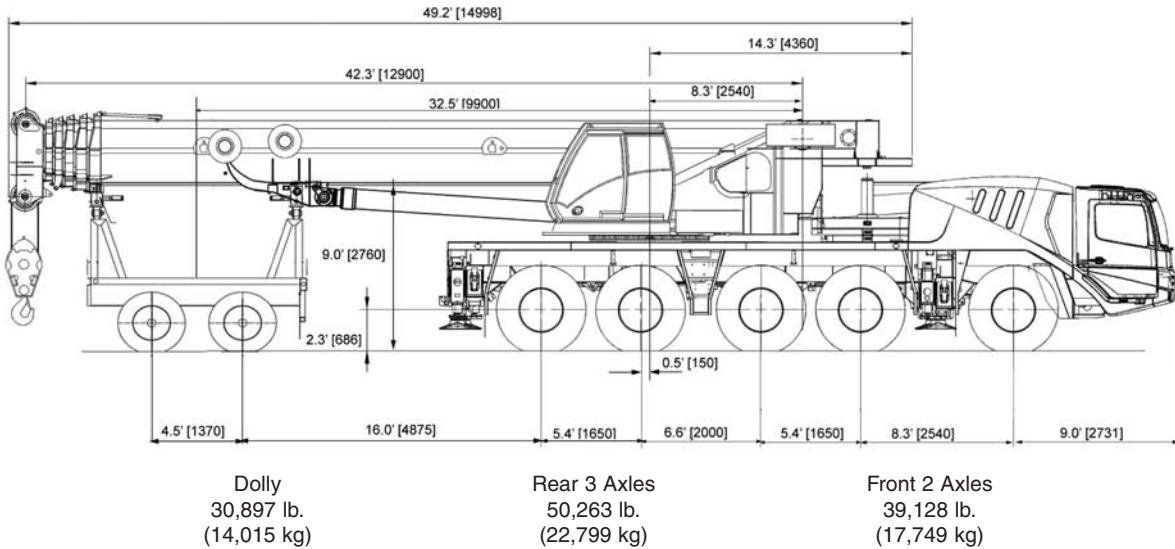

Unit Configuration:

- 42' – 197' boom
- Outrigger pads stowed on unit
- 10 X 8 X 10 drive/steer
- Main and auxiliary hoists with cable
- 36 – 59 ft. hydraulic luffing swingaway
- Additional oil cooler
- 20.5 tires
- 2 axle boom dolly (5,710 lb. / 2590 kg)

Boom Over Front

Basic Weights - lbs (kg)	Axles 1 & 2		Axles 3 - 5		Total	
Mercedes power, 16.00R25 tires, 10x6x10 drive/steer, 2nd oil cooler, outrigger pads, auxiliary hoist, driver and tanks filled	43,004	(19,506)	66,561	(30,192)	109,565	(49,698)
Additions:						
10x8x10 drive/steer	596	(270)	187	(85)	783	(355)
Electric driveline retarder	-187	(-85)	760	(345)	573	(260)
Spare wheel 14.00 R25 XGC steel rim with stowage	-474	(-215)	1,045	(474)	571	(259)
Spare wheel 16.00 R25 XGC steel rim with stowage	-592	(-268)	1,295	(587)	703	(319)
Spare wheel 20.5 R25 XGC steel rim with stowage	-680	(-309)	1,478	(671)	798	(362)
Brackets for hydraulic swingaway	161	(73)	17	(8)	179	(81)
Hose reel + parts for hydraulic swingaway	674	(306)	-211	(-96)	463	(210)
36 ft. - 59 ft. (11-18m) hydraulic swingaway	3,549	(1,610)	-242	(-110)	3,307	(1,500)
Auxiliary boom nose	334	(152)	-180	(-82)	154	(70)
5,500 lb. (2500 kg) section 8 pinned to superstructure	-4,414	(-2,002)	9,926	(4,502)	5,512	(2,500)
5,500 lb. (2500 kg) section 1 stowed on carrier	3,922	(1,770)	1,302	(591)	5,225	(2,370)
Substitutions:						
14.00R25 tires	-504	(-228)	-819	(-372)	-1,323	(-600)
20.5R25 tires	361	(164)	587	(266)	948	(430)
Removals:						
Boom assembly	-25,491	(-11,563)	-8,058	(-3,655)	-33,550	(-15,218)
Front outriggers	-3,095	(-1,404)	-13	(-6)	-3,109	(-1,410)
Rear outriggers	2,250	(1,021)	-5,557	(-2,521)	-3,307	(-1,500)
Front and rear outrigger floats	-69	(-32)	-371	(-168)	-441	(-200)

GMK5165-2

working range

42'-197' main boom

8

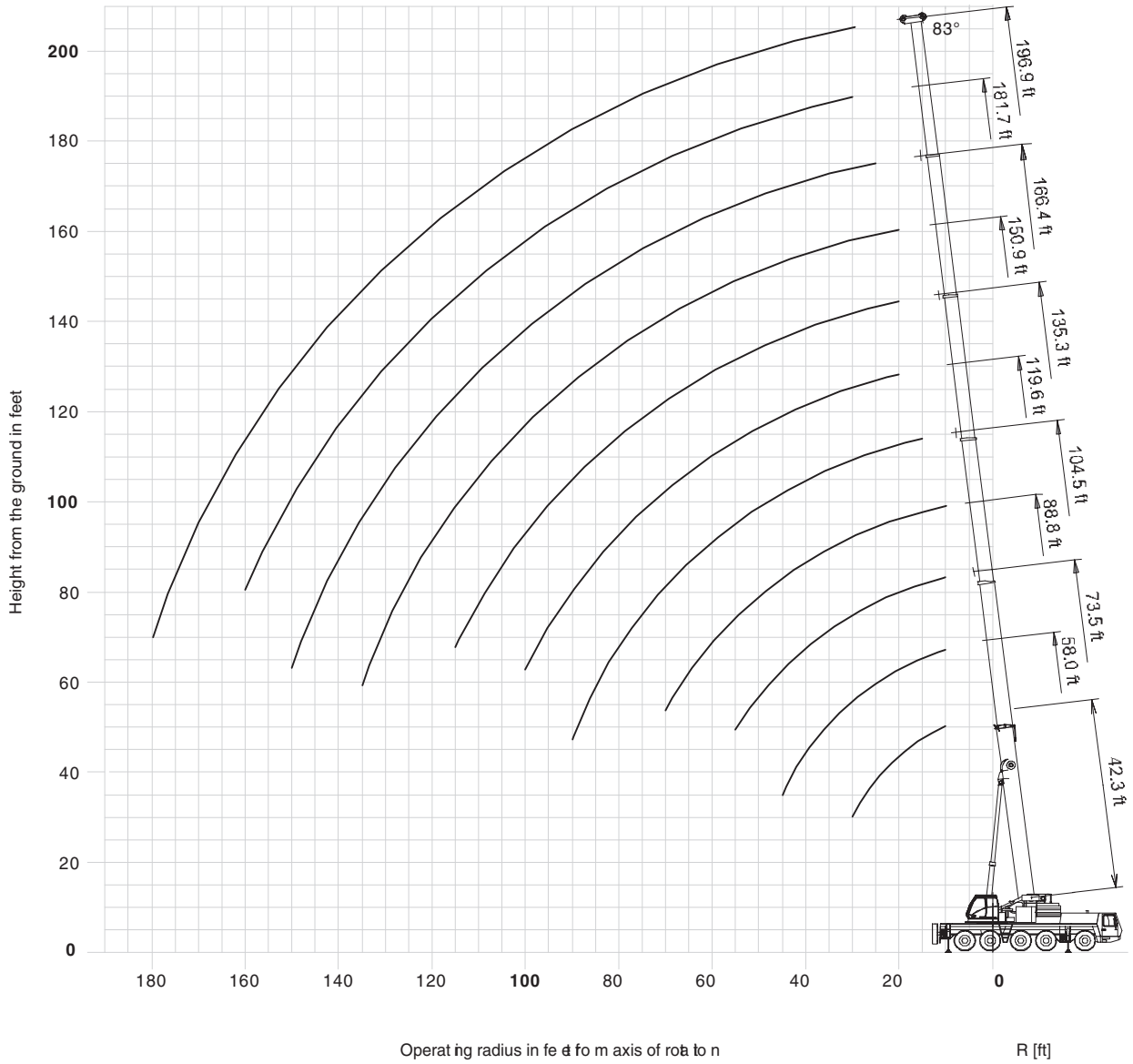

GMK5165-2

THIS CHART IS ONLY A GUIDE AND SHOULD NOT BE USED TO OPERATE THE CRANE. The individual crane's load chart, operating instructions and other instructional plates must be read and understood prior to operating the crane.

GROVE

load charts

9

 42-197 ft.
(12.8-60.0 m)
  88,400 lb.
(40,100 kg)
  100%
24'7" Spread
  360°

		Pounds (thousands)										
Feet	42'	58'	73'	89'	104'	119'	135'	150'	166'	181'	197'	
8	*240.0											
10	215.0	199.0	186.0	143.0								
15	168.0	165.0	154.0	143.0	110.0							
20	136.0	137.0	132.0	125.0	108.0	84.0	62.0	45.0				
25	113.0	114.0	114.0	110.0	98.0	78.0	62.0	45.0				
30	92.0	97.0	96.0	95.0	90.0	72.0	61.0	45.0	35.2	25.6	22.0	
35		83.0	83.0	82.0	82.0	66.0	56.0	45.0	35.2	25.6	22.0	
40		72.0	72.0	71.0	72.0	60.0	51.0	45.0	35.2	25.6	22.0	
45		61.0	64.0	62.0	61.0	56.0	47.0	41.4	35.2	25.6	22.0	
50			56.0	56.0	53.0	52.0	42.6	38.4	34.8	25.6	22.0	
55			48.0	50.0	47.0	47.0	39.2	35.6	32.4	25.6	22.0	
60				43.4	41.4	42.2	35.8	32.8	29.8	25.6	22.0	
65				38.2	37.6	37.8	32.6	29.8	27.8	25.6	22.0	
70				34.0	35.4	34.0	30.2	27.4	25.8	24.4	21.6	
75				27.2	32.0	30.8	28.0	25.4	24.0	23.0	20.6	
80					29.0	27.6	26.4	23.8	22.2	21.4	19.6	
85					26.2	24.8	25.2	22.0	20.8	20.0	18.6	
90					23.8	22.4	23.8	20.8	19.4	18.8	17.8	
95						21.0	21.6	19.0	18.2	17.6	17.0	
100						20.0	19.6	17.0	17.0	16.4	16.0	
105							18.0	15.8	15.6	15.0	14.8	
110							16.4	14.8	14.2	13.8	13.6	
115								15.0	14.0	12.8	12.8	
120									13.4	11.6	12.0	
125									12.8	10.4	11.4	
130									12.2	9.8	11.0	
135									11.2	9.4	10.0	
140										8.8	9.0	
145										8.4	8.2	
150										8.0	7.4	
155											6.8	
160											6.0	
165											5.4	
170											4.8	
175											4.4	
180											3.8	

*Over rear

 42-197 ft.
(12.8-60.0 m)
  46,200 lb.
(21,000 kg)
  100%
24'7" Spread
  360°

		Pounds (thousands)										
Feet	42'	58'	73'	89'	104'	119'	135'	150'	166'	181'	197'	
10	210.0	199.0	186.0	143.0								
15	164.0	163.0	154.0	143.0	110.0							
20	131.0	132.0	131.0	124.0	108.0	84.0	62.0	45.0				
25	107.0	108.0	101.0	93.0	89.0	78.0	62.0	45.0	35.2			
30	85.0	85.0	78.0	76.0	70.0	69.0	61.0	45.0	35.2	25.6	22.0	
35		68.0	65.0	62.0	61.0	57.0	53.0	45.0	35.2	25.6	22.0	
40		55.0	54.0	51.0	51.0	48.0	44.0	42.8	35.2	25.6	22.0	
45		46.0	46.0	45.0	43.8	40.6	41.0	36.4	35.2	25.6	22.0	
50			40.0	40.2	37.8	35.6	35.6	31.2	30.6	25.6	22.0	
55			34.8	35.2	33.0	32.8	31.0	28.2	26.6	25.6	22.0	
60				30.6	29.0	29.8	27.4	26.4	23.2	23.8	22.0	
65				26.6	25.8	26.4	24.2	24.4	21.6	22.4	21.0	
70				23.4	22.6	23.8	21.6	21.8	20.2	20.4	18.8	
75				15.0	19.8	21.4	19.2	19.4	19.0	18.2	16.6	
80					17.6	19.0	17.2	17.6	17.8	16.4	14.8	
85					15.4	16.8	15.4	15.8	16.0	14.8	13.2	
90					13.8	15.0	13.8	14.2	14.4	13.2	11.8	
95						13.6	12.2	13.2	13.2	11.8	10.4	
100						12.8	11.0	12.4	11.8	10.8	9.4	
105							10.4	11.4	10.8	9.6	8.2	
110							9.8	10.4	9.8	8.6	7.2	
115								9.2	8.6	7.8	6.4	
120								8.4	7.8	7.0	5.6	
125								7.6	6.8	6.0	4.8	
130								6.8	6.0	5.4	4.2	
135								6.0	5.4	4.6	3.6	
140									4.8	4.0	3.0	
145									4.0	3.4	2.4	
150									3.6	2.8		
155										2.2		

THIS CHART IS ONLY A GUIDE AND SHOULD NOT BE USED TO OPERATE THE CRANE. The individual crane's load chart, operating instructions and other instructional plates must be read and understood prior to operating the crane.

GMK5165-2

load charts

10

42-197 ft.
(12.8-60.0 m)
 2,200 lb.
(1000 kg)
 100%
24'7" Spread
 360°

Feet	Pounds (thousands)										
	42'	58'	73'	89'	104'	119'	135'	150'	166'	181'	197'
10	205.0	199.0	186.0	143.0							
15	153.0	141.0	123.0	113.0	99.0						
20	93.0	87.0	81.0	78.0	71.0	64.0	58.0	45.0			
25	64.0	63.0	61.0	57.0	53.0	52.0	47.0	41.8	35.2		
30	46.0	47.0	46.0	43.8	40.2	40.0	36.0	36.2	29.8	25.6	22.0
35		36.2	36.6	36.4	31.8	33.8	31.8	29.8	27.6	24.2	22.0
40		28.4	29.2	29.4	28.4	27.6	26.0	24.4	22.4	20.4	18.2
45		22.0	23.8	24.2	23.8	22.8	21.6	20.2	18.6	16.8	14.8
50			19.6	20.2	19.8	19.2	18.2	16.8	15.4	13.8	12.0
55			16.0	17.0	16.8	16.2	15.4	14.2	13.0	11.4	9.6
60				14.4	14.2	13.8	13.0	12.0	10.8	9.4	7.8
65				12.0	12.2	11.8	11.0	10.0	9.0	7.6	6.2
70					10.4	10.2	9.4	8.4	7.4	6.2	4.6
75						8.8	8.6	8.0	7.2	6.2	4.8
80						7.4	7.4	6.8	6.0	5.0	3.8
85							6.2	5.6	4.8	4.0	2.8
90					5.0	5.2	4.6	4.0	3.0		
95						4.2	3.8	3.0	2.2		
100							3.4	3.0	2.4		
105								2.2			

GMK5165-2

THIS CHART IS ONLY A GUIDE AND SHOULD NOT BE USED TO OPERATE THE CRANE. The individual crane's load chart, operating instructions and other instructional plates must be read and understood prior to operating the crane.

working range

swingaway

42'-197' main boom

11

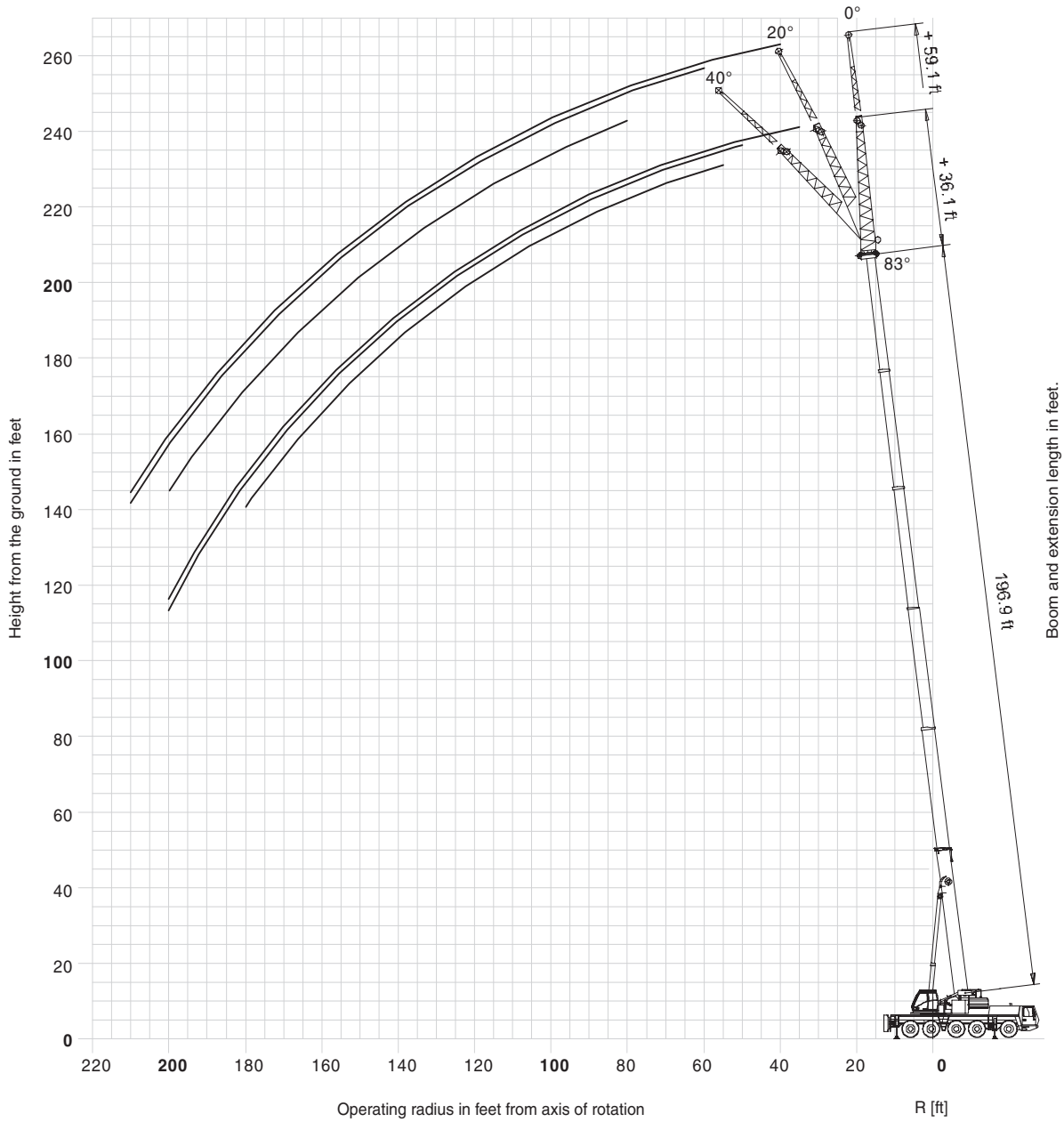

Hook heights shown in the working range diagram do not consider loaded boom deflection.

THIS CHART IS ONLY A GUIDE AND SHOULD NOT BE USED TO OPERATE THE CRANE. The individual crane's load chart, operating instructions and other instructional plates must be read and understood prior to operating the crane.

GMK5165-2

GROVE

working range

swingaway

42'-197' main boom

12

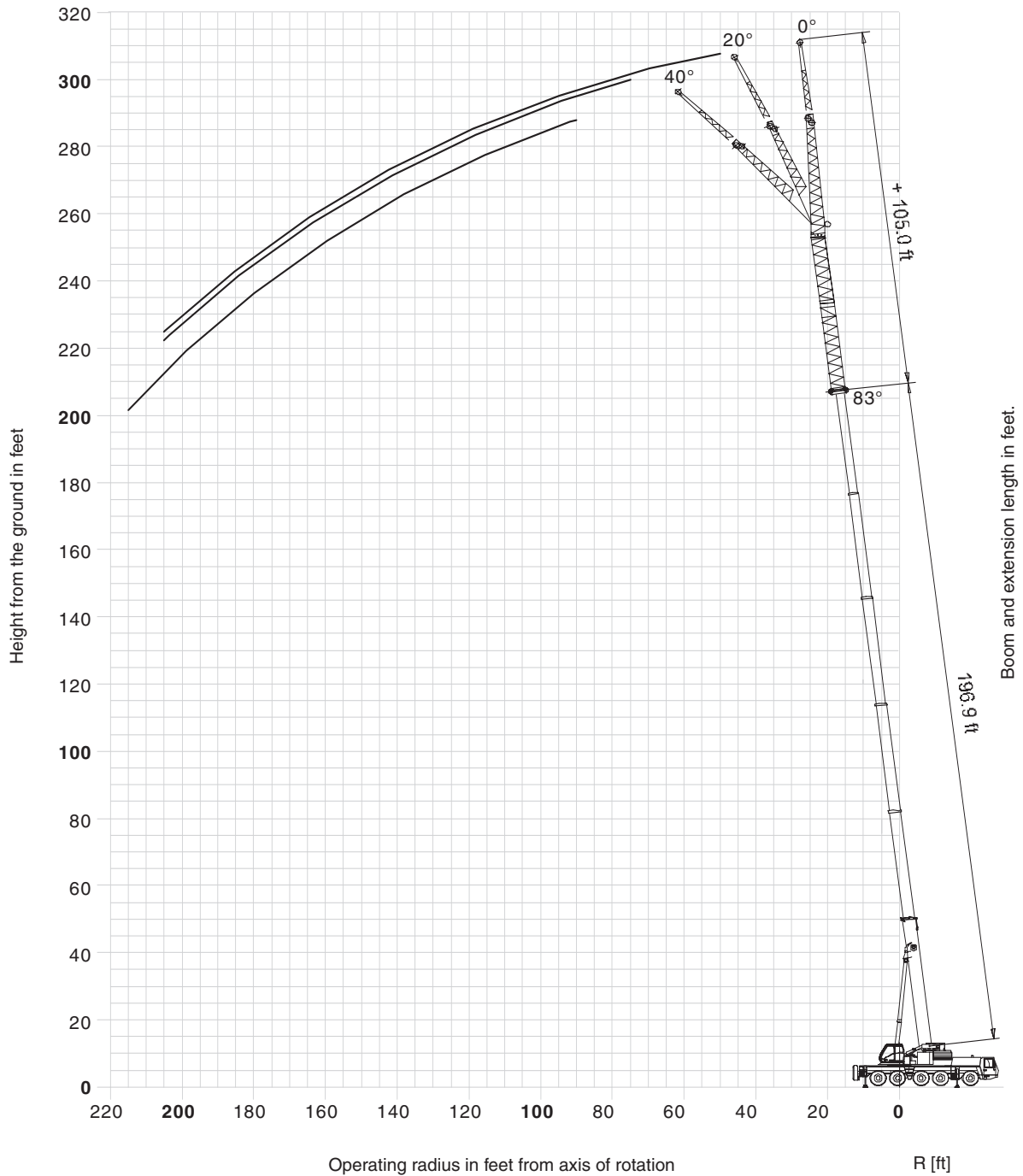

Hook heights shown in the working range diagram do not consider loaded boom deflection.

THIS CHART IS ONLY A GUIDE AND SHOULD NOT BE USED TO OPERATE THE CRANE. The individual crane's load chart, operating instructions and other instructional plates must be read and understood prior to operating the crane.

GMK5165-2

GROVE

load charts

hydraulic offsettable swingaway

Feet	Pounds (thousands)											
	36 FT			59 FT			85 FT			105 FT		
	0°	0°-20°	20°-40°	0°	0°-20°	20°-40°	0°	0°-20°	20°-40°	0°	0°-20°	20°-40°
20												
25												
30												
35	11.6			8.0								
40	11.6			8.0								
45	11.6			8.0								
50	11.6	11.6		8.0			5.6			4.2		
55	11.6	11.6	11.6	8.0			5.6			4.2		
60	11.6	11.6	11.6	8.0	8.0		5.6			4.2		
65	11.6	11.6	11.6	8.0	8.0		5.6			4.2		
70	11.6	11.6	11.6	8.0	8.0		5.6	5.6		4.2		
75	11.6	11.6	11.6	8.0	8.0		5.6	5.6		4.2	4.2	
80	11.6	11.6	11.6	8.0	8.0	8.0	5.6	5.6		4.2	4.2	
85	11.6	11.6	11.6	8.0	8.0	8.0	5.6	5.6		4.2	4.2	
90	11.6	11.6	11.6	8.0	8.0	8.0	5.6	5.6	5.6	4.2	4.2	4.0
95	11.6	11.6	11.6	8.0	8.0	8.0	5.6	5.6	5.6	4.2	4.2	4.0
100	11.4	11.4	11.4	8.0	8.0	8.0	5.6	5.6	5.6	4.2	4.2	4.0
105	11.0	10.8	11.0	8.0	8.0	8.0	5.6	5.6	5.6	4.2	4.2	4.0
110	10.6	10.4	10.6	8.0	8.0	8.0	5.6	5.6	5.6	4.2	4.2	4.0
115	10.0	10.0	10.0	8.0	8.0	8.0	5.6	5.6	5.6	4.2	4.2	4.0
120	9.6	9.6	9.6	8.0	8.0	8.0	5.6	5.6	5.6	4.2	4.2	4.0
125	9.2	9.2	9.2	8.0	8.0	8.0	5.6	5.6	5.6	4.2	4.2	4.0
130	8.8	8.8	8.8	7.8	7.8	8.0	5.6	5.6	5.6	4.2	4.2	4.0
135	8.4	8.4	8.6	7.4	7.6	7.8	5.6	5.6	5.6	4.2	4.2	4.0
140	8.0	8.0	8.2	7.2	7.2	7.4	5.6	5.6	5.6	4.2	4.2	4.0
145	7.8	7.8	7.8	6.8	7.0	7.2	5.6	5.6	5.6	4.2	4.2	4.0
150	7.4	7.4	7.6	6.6	6.6	6.8	5.4	5.4	5.6	4.2	4.2	4.0
155	6.8	6.8	7.2	6.4	6.4	6.6	5.0	5.2	5.6	4.2	4.2	4.0
160	6.2	6.2	6.6	6.0	6.2	6.4	4.8	5.0	5.2	4.0	4.2	4.0
165	5.4	5.4	6.0	5.8	6.0	6.2	4.6	4.8	5.0	3.8	4.0	4.0
170	5.0	5.0	5.2	5.6	5.6	5.8	4.4	4.6	4.8	3.6	3.8	4.0
175	4.4	4.4	4.8	5.2	5.2	5.6	4.2	4.4	4.6	3.4	3.6	4.0
180	3.8	3.8	4.2	4.6	4.6	5.4	4.0	4.2	4.4	3.2	3.4	3.8
185	3.4	3.4		4.0	4.0	4.8	3.8	4.0	4.2	3.0	3.2	3.6
190	2.8	2.8		3.6	3.6	4.2	3.6	3.6	4.0	3.0	3.2	3.4
195	2.4	2.4		3.2	3.2	3.8	3.2	3.2	3.8	2.8	3.0	3.2
200	2.0	2.0		2.8	2.8	3.2	2.8	2.8	3.4	2.6	2.6	3.0
205				2.4	2.4		2.4	2.4	3.0	2.2	2.2	
210				2.0	2.0		2.0	2.0	2.4			2.8
215									2.0			2.4
220												2.0
225												

13

Feet	Pounds (thousands)											
	36 FT			59 FT			85 FT			105 FT		
	0°	0°-20°	20°-40°	0°	0°-20°	20°-40°	0°	0°-20°	20°-40°	0°	0°-20°	20°-40°
20												
25												
30												
35	11.6			8.0								
40	11.6			8.0								
45	11.6			8.0								
50	11.6	11.6		8.0			5.6			4.2		
55	11.6	11.6	11.6	8.0			5.6			4.2		
60	11.6	11.6	11.6	8.0	8.0		5.6			4.2		
65	11.6	11.6	11.6	8.0	8.0		5.6			4.2		
70	11.6	11.6	11.6	8.0	8.0		5.6	5.6		4.2		
75	11.6	11.6	11.6	8.0	8.0		5.6	5.6		4.2	4.2	
80	11.6	11.6	11.6	8.0	8.0	8.0	5.6	5.6		4.2	4.2	
85	11.6	11.6	11.6	8.0	8.0	8.0	5.6	5.6		4.2	4.2	
90	11.0	11.0	11.6	8.0	8.0	8.0	5.6	5.6	5.6	4.2	4.2	4.0
95	9.8	9.8	11.0	8.0	8.0	8.0	5.6	5.6	5.6	4.2	4.2	4.0
100	8.8	8.8	9.8	8.0	8.0	8.0	5.6	5.6	5.6	4.2	4.2	4.0
105	7.8	7.8	8.6	8.0	8.0	8.0	5.6	5.6	5.6	4.2	4.2	4.0
110	6.8	6.8	7.6	7.4	7.4	8.0	5.6	5.6	5.6	4.2	4.2	4.0
115	6.0	6.0	6.8	6.6	6.6	8.0	5.6	5.6	5.6	4.2	4.2	4.0
120	5.2	5.2	6.0	5.8	5.8	7.2	5.4	5.4	5.6	4.2	4.2	4.0
125	4.4	4.4	5.2	5.0	5.0	6.4	4.8	4.8	5.6	4.2	4.2	4.0
130	3.8	3.8	4.4	4.4	4.4	5.6	4.2	4.2	5.4	4.0	4.0	4.0
135	3.2	3.2	3.8	3.8	3.8	5.0	3.6	3.6	4.8	3.4	3.4	4.0
140	2.6	2.6	3.2	3.2	3.2	4.4	3.0	3.0	4.2	2.8	2.8	4.0
145	2.0	2.0	2.6	2.6	2.6	3.8	2.4	2.4	3.6	2.2	2.2	3.4
150			2.0	2.2	2.2	3.2	2.0	2.0	3.0			2.8
155						2.6			2.4			2.4
160						2.2			2.0			





THIS CHART IS ONLY A GUIDE AND SHOULD NOT BE USED TO OPERATE THE CRANE. The individual crane's load chart, operating instructions and other instructional plates must be read and understood prior to operating the crane.





GMK5165-2

load charts

manual offsettable swingaway

14

    												
Pounds (thousands)												
Feet	36 FT			59 FT			85 FT			105 FT		
	0°	20°	40°	0°	20°	40°	0°	20°	40°	0°	20°	40°
20												
25												
30												
35	11.6											
40	11.6			8.0								
45	11.6			8.0								
50	11.6	11.6		8.0			5.6			4.2		
55	11.6	11.6	11.6	8.0			5.6			4.2		
60	11.6	11.6	11.6	8.0	8.0		5.6			4.2		
65	11.6	11.6	11.6	8.0	8.0		5.6			4.2		
70	11.6	11.6	11.6	8.0	8.0		5.6	5.6		4.2		
75	11.6	11.6	11.6	8.0	8.0		5.6	5.6		4.2	4.2	
80	11.6	11.6	11.6	8.0	8.0	8.0	5.6	5.6		4.2	4.2	
85	11.6	11.6	11.6	8.0	8.0	8.0	5.6	5.6		4.2	4.2	
90	11.6	11.6	11.6	8.0	8.0	8.0	5.6	5.6	5.6	4.2	4.2	4.0
95	11.6	11.6	11.6	8.0	8.0	8.0	5.6	5.6	5.6	4.2	4.2	4.0
100	11.4	11.4	11.4	8.0	8.0	8.0	5.6	5.6	5.6	4.2	4.2	4.0
105	11.0	10.8	11.0	8.0	8.0	8.0	5.6	5.6	5.6	4.2	4.2	4.0
110	10.6	10.4	10.6	8.0	8.0	8.0	5.6	5.6	5.6	4.2	4.2	4.0
115	10.0	10.0	10.0	8.0	8.0	8.0	5.6	5.6	5.6	4.2	4.2	4.0
120	9.6	9.6	9.6	8.0	8.0	8.0	5.6	5.6	5.6	4.2	4.2	4.0
125	9.2	9.2	9.2	8.0	8.0	8.0	5.6	5.6	5.6	4.2	4.2	4.0
130	8.8	8.8	8.8	7.8	7.8	8.0	5.6	5.6	5.6	4.2	4.2	4.0
135	8.4	8.4	8.6	7.4	7.6	7.8	5.6	5.6	5.6	4.2	4.2	4.0
140	8.0	8.0	8.2	7.2	7.2	7.4	5.6	5.6	5.6	4.2	4.2	4.0
145	7.8	7.8	7.8	6.8	7.0	7.2	5.6	5.6	5.6	4.2	4.2	4.0
150	7.4	7.4	7.6	6.6	6.6	6.8	5.4	5.4	5.6	4.2	4.2	4.0
155	6.8	7.0	7.2	6.4	6.4	6.6	5.0	5.2	5.6	4.2	4.2	4.0
160	6.2	6.6	6.8	6.0	6.2	6.4	4.8	5.0	5.2	4.0	4.2	4.0
165	5.4	6.0	6.2	5.8	6.0	6.2	4.6	4.8	5.0	3.8	4.0	4.0
170	5.0	5.2	5.4	5.6	5.6	5.8	4.4	4.6	4.8	3.6	3.8	4.0
175	4.4	4.8	4.8	5.2	5.4	5.6	4.2	4.4	4.6	3.4	3.6	4.0
180	3.8	4.2	4.2	4.6	5.2	5.4	4.0	4.2	4.4	3.2	3.4	3.8
185	3.4	3.6		4.0	4.8	5.0	3.8	4.0	4.2	3.0	3.2	3.6
190	2.8	3.2		3.6	4.2	4.6	3.6	3.8	4.0	3.0	3.2	3.4
195	2.4	2.6		3.2	3.8	4.0	3.2	3.6	3.8	2.8	3.0	3.2
200	2.0	2.2		2.8	3.2	3.4	2.8	3.4	3.6	2.6	2.8	3.0
205				2.4	2.8		2.4	3.0	3.2	2.2	2.6	2.8
210				2.0	2.4		2.0	2.4	2.8		2.4	2.6
215					2.0			2.0	2.4		2.0	2.4
220												2.0
225												

    												
Pounds (thousands)												
Feet	36 FT			59 FT			85 FT			105 FT		
	0°	20°	40°	0°	20°	40°	0°	20°	40°	0°	20°	40°
20												
25												
30												
35	11.6											
40	11.6			8.0								
45	11.6			8.0								
50	11.6	11.6		8.0			5.6			4.2		
55	11.6	11.6	11.6	8.0			5.6			4.2		
60	11.6	11.6	11.6	8.0	8.0		5.6			4.2		
65	11.6	11.6	11.6	8.0	8.0		5.6			4.2		
70	11.6	11.6	11.6	8.0	8.0		5.6	5.6		4.2		
75	11.6	11.6	11.6	8.0	8.0		5.6	5.6		4.2	4.2	
80	11.6	11.6	11.6	8.0	8.0	8.0	5.6	5.6		4.2	4.2	
85	11.6	11.6	11.6	8.0	8.0	8.0	5.6	5.6		4.2	4.2	
90	11.0	11.6	11.6	8.0	8.0	8.0	5.6	5.6	5.6	4.2	4.2	4.0
95	9.8	11.0	11.6	8.0	8.0	8.0	5.6	5.6	5.6	4.2	4.2	4.0
100	8.8	9.8	10.6	8.0	8.0	8.0	5.6	5.6	5.6	4.2	4.2	4.0
105	7.8	8.6	9.4	8.0	8.0	8.0	5.6	5.6	5.6	4.2	4.2	4.0
110	6.8	7.6	8.4	7.4	8.0	8.0	5.6	5.6	5.6	4.2	4.2	4.0
115	6.0	6.8	7.4	6.6	8.0	8.0	5.6	5.6	5.6	4.2	4.2	4.0
120	5.2	6.0	6.4	5.8	7.2	8.0	5.4	5.6	5.6	4.2	4.2	4.0
125	4.4	5.2	5.6	5.0	6.4	7.4	4.8	5.6	5.6	4.2	4.2	4.0
130	3.8	4.4	4.8	4.4	5.6	6.6	4.2	5.4	5.6	4.0	4.2	4.0
135	3.2	3.8	4.2	3.8	5.0	5.8	3.6	4.8	5.6	3.4	4.2	4.0
140	2.6	3.2	3.6	3.2	4.4	5.2	3.0	4.2	5.0	2.8	4.0	4.0
145	2.0	2.6	3.0	2.6	3.8	4.4	2.4	3.6	4.4	2.2	3.4	4.0
150		2.0	2.4	2.2	3.2	3.8	2.0	3.0	3.8		2.8	3.6
155					2.6	3.2		2.4	3.2		2.4	3.2
160					2.2	2.8		2.0	2.6			2.6
165						2.2			2.2			2.0
170												
175												
180												
185												

GMK5165-2

THIS CHART IS ONLY A GUIDE AND SHOULD NOT BE USED TO OPERATE THE CRANE. The individual crane's load chart, operating instructions and other instructional plates must be read and understood prior to operating the crane.

3 177 651

	Crane with 62 800 lbs (28.5 t) counterweight					
	Outrigger base - length 25.6 ft - width 16.8 ft					
	Main boom - fixed length in ft					
	42.3	57.5	57.6	57.8	57.9	58.0
Tel. sec. I	0.00	0.00	0.00	0.00	0.00	0.50
Tel. sec. II	0.00	0.00	0.00	0.00	0.50	0.00
Tel. sec. III	0.00	0.00	0.00	0.50	0.00	0.00
Tel. sec. IV	0.00	0.00	0.50	0.00	0.00	0.00
Tel. sec. V	0.00	0.50	0.00	0.00	0.00	0.00
Slewing range	360°					
Radius in feet	Lifting capacities in 1000 lbs					
10.0	195.0	102.0	120.0	167.0	195.0	193.0
15.0	148.0	97.0	120.0	149.0	148.0	146.0
20.0	117.0	83.0	114.0	118.0	116.0	113.0
25.0	93.0	73.0	89.0	87.0	85.0	82.0
30.0	70.0	66.0	69.0	67.0	65.0	63.0
35.0		57.0	56.0	54.0	52.0	50.0
40.0		47.0	46.0	44.0	42.6	40.6
45.0		38.6	37.6	36.2	34.4	32.4
SLI Code	2103					
Max. permitted windspeed	14 m/s					

	Crane with 62 800 lbs (28.5 t) counterweight								
	Outrigger base - length 25.6 ft - width 16.8 ft								
	Main boom - fixed length in ft								
	72.6	72.8	73.0	73.2	73.3	73.4	73.5	73.6	73.8
Tel. sec. I	0.00	0.00	0.00	0.00	0.00	0.00	0.00	0.50	1.00
Tel. sec. II	0.00	0.00	0.00	0.00	0.00	0.50	1.00	0.50	0.00
Tel. sec. III	0.00	0.00	0.00	0.50	1.00	0.50	0.00	0.00	0.00
Tel. sec. IV	0.00	0.50	1.00	0.50	0.00	0.00	0.00	0.00	0.00
Tel. sec. V	1.00	0.50	0.00	0.00	0.00	0.00	0.00	0.00	0.00
Slewing range	360°								
Radius in feet	Lifting capacities in 1000 lbs								
10.0	80.0	102.0	97.0	120.0	93.0	167.0	88.0	186.0	83.0
15.0	66.0	93.0	80.0	114.0	93.0	149.0	88.0	147.0	83.0
20.0	57.0	78.0	67.0	96.0	83.0	109.0	88.0	104.0	83.0
25.0	49.0	68.0	58.0	83.0	72.0	81.0	79.0	77.0	75.0
30.0	43.4	59.0	51.0	66.0	63.0	63.0	61.0	59.0	58.0
35.0	38.8	53.0	45.0	54.0	52.0	51.0	49.0	47.0	46.0
40.0	35.2	47.0	41.0	45.0	43.2	42.0	40.2	38.6	36.8
45.0	31.8	40.2	37.2	38.0	36.4	35.2	33.6	32.0	30.2
50.0	29.2	34.2	33.0	32.4	31.0	29.8	28.2	26.8	25.0
55.0	27.2	29.2	28.0	27.4	25.8	24.8	23.4	22.0	20.4
SLI Code	2103								
Max. permitted windspeed	14 m/s								

3 177 651

	Crane with 62 800 lbs (28.5 t) counterweight									
	Outrigger base - length 25.6 ft - width 16.8 ft									
	Main boom - fixed length in ft									
	87.9	88.3	88.8	89.1	103.3	103.9	104.5	118.8	119.0	119.6
Tel. sec. I	0.00	0.00	0.00	0.50	0.00	0.00	0.50	0.00	0.00	0.50
Tel. sec. II	0.00	0.00	0.50	0.50	0.00	0.50	0.50	0.00	0.50	0.50
Tel. sec. III	0.00	0.50	0.50	0.50	0.00	0.50	0.50	0.50	0.50	0.50
Tel. sec. IV	0.50	0.50	0.50	0.00	1.00	0.50	0.50	1.00	0.50	0.50
Tel. sec. V	1.00	0.50	0.00	0.00	1.00	0.50	0.00	1.00	1.00	0.50
Slewing range	360°									
Radius in feet	Lifting capacities in 1000 lbs									
10.0	77.0	102.0	120.0	143.0						
15.0	65.0	95.0	120.0	143.0	55.0	98.0	110.0			
20.0	56.0	81.0	104.0	99.0	47.0	86.0	95.0	48.0	61.0	84.0
25.0	48.0	71.0	79.0	74.0	41.0	77.0	72.0	43.2	56.0	71.0
30.0	42.2	62.0	62.0	58.0	36.2	61.0	57.0	38.8	50.0	57.0
35.0	37.6	54.0	51.0	47.0	31.8	51.0	47.0	35.0	45.0	47.0
40.0	33.8	45.0	42.0	38.4	28.4	42.4	38.6	31.0	41.6	39.2
45.0	30.4	38.6	35.4	32.0	25.8	36.2	32.4	28.4	36.6	33.4
50.0	27.8	33.4	30.4	26.8	23.6	31.2	27.6	26.2	31.8	28.6
55.0	25.8	29.2	26.2	22.8	21.8	27.2	23.6	24.2	27.8	24.6
60.0	23.8	25.4	22.8	19.4	20.0	23.8	20.2	22.4	24.6	21.4
65.0	22.2	22.0	19.4	16.4	18.6	21.0	17.4	21.0	21.8	18.6
70.0	20.8	19.2	16.6	13.6	17.4	18.6	15.2	19.6	19.4	16.4
75.0				11.4	16.0	16.2	13.0	18.2	17.2	14.4
80.0					14.4	14.0	11.0	17.0	15.6	12.6
85.0					13.6	12.4	9.2	15.2	13.8	11.0
90.0					12.8	10.8	7.8	13.6	12.2	9.4
95.0								12.2	10.8	8.0
100.0								10.8	9.6	6.8
SLI Code	2103									
Max. permitted windspeed	14 m/s							12 m/s		

	Crane with 62 800 lbs (28.5 t) counterweight					
	Outrigger base - length 25.6 ft - width 16.8 ft					
	Main boom - fixed length in ft					
	134.3	134.8	135.3	149.9	150.1	150.9
Tel. sec. I	0.00	0.50	1.00	0.00	0.50	1.00
Tel. sec. II	0.00	0.50	0.50	0.50	0.50	1.00
Tel. sec. III	1.00	0.50	0.50	1.00	0.50	0.50
Tel. sec. IV	1.00	0.50	0.50	1.00	1.00	0.50
Tel. sec. V	1.00	1.00	0.50	1.00	1.00	0.50
Slewing range	360°					
Radius in feet	Lifting capacities in 1000 lbs					
20.0	41.8	57.0	62.0	36.4	41.8	45.0
25.0	40.0	56.0	62.0	36.4	41.8	45.0
30.0	36.0	52.0	53.0	36.2	40.8	45.0
35.0	32.2	47.0	43.6	33.4	38.0	41.6
40.0	28.8	39.4	36.4	30.2	35.6	35.0
45.0	26.2	33.8	30.8	27.8	32.6	29.6
50.0	23.8	29.2	26.2	25.6	29.2	25.2
55.0	22.0	25.4	22.6	23.6	25.6	21.8
60.0	20.2	22.4	19.4	21.8	22.4	18.8
65.0	18.6	19.6	16.8	20.4	19.8	16.2
70.0	17.4	17.4	14.6	19.0	17.6	14.0
75.0	15.8	15.4	12.6	17.0	15.6	12.0
80.0	14.2	13.6	10.8	15.2	14.0	10.4
85.0	13.2	12.0	9.4	13.8	12.4	8.8
90.0	12.4	10.8	8.0	12.4	11.0	7.6
95.0	11.8	9.4	6.8	11.2	9.8	6.4
100.0	10.6	8.2	5.8	10.0	8.8	5.4
105.0	9.4	7.2	4.6	9.0	7.8	4.4
110.0	8.4	6.2	3.6	8.0	6.8	3.4
115.0	7.6	5.2	2.8	7.2	6.0	2.8
120.0				6.4	5.2	
125.0				5.6	4.4	
130.0				4.8	3.8	
135.0				4.2	3.0	
SLI Code	2103					
Max. permitted windspeed	12 m/s					

3 177 651

	Crane with 62 800 lbs (28.5 t) counterweight				
	Outrigger base - length 25.6 ft - width 16.8 ft				
	Main boom - fixed length in ft				
	165.5	166.4	181.1	181.7	196.9
Tel. sec. I	0.00	1.00	0.50	1.00	1.00
Tel. sec. II	1.00	1.00	1.00	1.00	1.00
Tel. sec. III	1.00	1.00	1.00	1.00	1.00
Tel. sec. IV	1.00	0.50	1.00	1.00	1.00
Tel. sec. V	1.00	0.50	1.00	0.50	1.00
Slewing range	360°				
Radius in feet	Lifting capacities in 1000 lbs				
25.0	29.8	35.2			
30.0	29.8	35.2	24.2	25.6	22.0
35.0	29.8	35.2	24.2	25.6	22.0
40.0	29.8	34.0	24.2	25.6	22.0
45.0	28.2	29.0	24.2	25.6	22.0
50.0	26.4	24.8	24.2	25.0	22.0
55.0	24.6	21.4	23.8	21.6	22.0
60.0	22.4	18.4	21.0	18.8	19.2
65.0	20.0	16.0	18.6	16.4	16.8
70.0	17.8	13.8	16.4	14.4	14.8
75.0	15.8	12.0	14.6	12.6	13.0
80.0	14.2	10.4	13.0	11.0	11.4
85.0	12.8	9.0	11.4	9.4	10.0
90.0	11.4	7.6	10.2	8.2	8.8
95.0	10.2	6.4	9.0	7.0	7.6
100.0	9.2	5.4	8.0	6.0	6.6
105.0	8.2	4.4	7.0	5.0	5.8
110.0	7.2	3.6	6.2	4.2	4.8
115.0	6.4	2.8	5.4	3.4	4.2
120.0	5.6		4.6	2.8	3.4
125.0	5.0		4.0		2.8
130.0	4.2		3.4		2.2
135.0	3.6		2.8		
140.0	3.0		2.2		
145.0	2.4				
SLI Code	2103				
Max. permitted windspeed	11 m/s	10 m/s			

3 177 652

	Crane with 57 300 lbs (26 t) counterweight					
	Outrigger base - length 25.6 ft - width 16.8 ft					
	Main boom - fixed length in ft					
	42.3	57.5	57.6	57.8	57.9	58.0
Tel. sec. I	0.00	0.00	0.00	0.00	0.00	0.50
Tel. sec. II	0.00	0.00	0.00	0.00	0.50	0.00
Tel. sec. III	0.00	0.00	0.00	0.50	0.00	0.00
Tel. sec. IV	0.00	0.00	0.50	0.00	0.00	0.00
Tel. sec. V	0.00	0.50	0.00	0.00	0.00	0.00
Slewing range	360°					
Radius in feet	Lifting capacities in 1000 lbs					
10.0	194.0	102.0	120.0	167.0	193.0	192.0
15.0	147.0	97.0	120.0	148.0	146.0	145.0
20.0	116.0	83.0	114.0	111.0	109.0	106.0
25.0	87.0	73.0	84.0	82.0	79.0	77.0
30.0	65.0	66.0	65.0	63.0	61.0	58.0
35.0		54.0	52.0	51.0	49.0	46.0
40.0		43.8	42.6	41.2	39.4	37.4
45.0		36.0	34.8	33.6	31.8	29.8
SLI Code	2003					
Max. permitted windspeed	14 m/s					

	Crane with 57 300 lbs (26 t) counterweight								
	Outrigger base - length 25.6 ft - width 16.8 ft								
	Main boom - fixed length in ft								
	72.6	72.8	73.0	73.2	73.3	73.4	73.5	73.6	73.8
Tel. sec. I	0.00	0.00	0.00	0.00	0.00	0.00	0.00	0.50	1.00
Tel. sec. II	0.00	0.00	0.00	0.00	0.00	0.50	1.00	0.50	0.00
Tel. sec. III	0.00	0.00	0.00	0.50	1.00	0.50	0.00	0.00	0.00
Tel. sec. IV	0.00	0.50	1.00	0.50	0.00	0.00	0.00	0.00	0.00
Tel. sec. V	1.00	0.50	0.00	0.00	0.00	0.00	0.00	0.00	0.00
Slewing range	360°								
Radius in feet	Lifting capacities in 1000 lbs								
10.0	80.0	102.0	97.0	120.0	93.0	167.0	88.0	186.0	83.0
15.0	66.0	93.0	80.0	114.0	93.0	148.0	88.0	145.0	83.0
20.0	57.0	78.0	67.0	96.0	83.0	102.0	88.0	98.0	83.0
25.0	49.0	68.0	58.0	79.0	72.0	76.0	74.0	72.0	70.0
30.0	43.4	59.0	51.0	62.0	60.0	59.0	57.0	55.0	53.0
35.0	38.8	53.0	45.0	50.0	49.0	47.0	46.0	44.0	42.2
40.0	35.2	44.0	41.0	41.8	40.2	38.8	37.2	35.6	33.8
45.0	31.8	37.4	36.0	35.2	33.6	32.4	30.8	29.2	27.6
50.0	29.2	31.8	30.6	30.0	28.6	27.4	25.8	24.2	22.6
55.0	27.2	27.2	25.8	25.2	23.8	22.8	21.2	19.8	18.2
SLI Code	2003								
Max. permitted windspeed	14 m/s								

3 177 652

	Crane with 57 300 lbs (26 t) counterweight									
	Outrigger base - length 25.6 ft - width 16.8 ft									
	Main boom - fixed length in ft									
	87.9	88.3	88.8	89.1	103.3	103.9	104.5	118.8	119.0	119.6
Tel. sec. I	0.00	0.00	0.00	0.50	0.00	0.00	0.50	0.00	0.00	0.50
Tel. sec. II	0.00	0.00	0.50	0.50	0.00	0.50	0.50	0.00	0.50	0.50
Tel. sec. III	0.00	0.50	0.50	0.50	0.00	0.50	0.50	0.50	0.50	0.50
Tel. sec. IV	0.50	0.50	0.50	0.00	1.00	0.50	0.50	1.00	0.50	0.50
Tel. sec. V	1.00	0.50	0.00	0.00	1.00	0.50	0.00	1.00	1.00	0.50
Slewing range	360°									
Radius in feet	Lifting capacities in 1000 lbs									
10.0	77.0	102.0	120.0	143.0						
15.0	65.0	95.0	120.0	135.0	55.0	98.0	110.0			
20.0	56.0	81.0	97.0	93.0	47.0	86.0	89.0	48.0	61.0	84.0
25.0	48.0	71.0	74.0	69.0	41.0	72.0	68.0	43.2	56.0	67.0
30.0	42.2	62.0	58.0	54.0	36.2	58.0	53.0	38.8	50.0	53.0
35.0	37.6	50.0	47.0	43.4	31.8	47.0	43.4	35.0	45.0	43.6
40.0	33.8	42.2	39.0	35.4	28.4	39.6	35.8	31.0	39.8	36.4
45.0	30.4	36.0	32.8	29.4	25.8	33.6	30.0	28.4	34.0	30.8
50.0	27.8	31.0	28.0	24.4	23.6	28.8	25.2	26.2	29.4	26.2
55.0	25.8	27.0	24.0	20.6	21.8	25.0	21.4	24.2	25.8	22.6
60.0	23.8	23.6	20.8	17.4	20.0	21.8	18.4	22.4	22.6	19.6
65.0	21.8	20.4	17.6	14.6	18.6	19.2	15.6	21.0	20.0	17.0
70.0	19.2	17.6	15.0	12.0	17.4	16.8	13.4	19.2	17.8	14.8
75.0				9.8	16.0	14.6	11.4	17.2	15.8	12.8
80.0					14.4	12.6	9.6	15.6	14.0	11.2
85.0					13.6	11.0	8.0	13.8	12.4	9.6
90.0					12.2	9.6	6.6	12.4	11.0	8.2
95.0								11.0	9.6	7.0
100.0								9.8	8.4	5.8
SLI Code	2003									
Max. permitted windspeed	14 m/s							12 m/s		

	Crane with 57 300 lbs (26 t) counterweight					
	Outrigger base - length 25.6 ft - width 16.8 ft					
	Main boom - fixed length in ft					
	134.3	134.8	135.3	149.9	150.1	150.9
Tel. sec. I	0.00	0.50	1.00	0.00	0.50	1.00
Tel. sec. II	0.00	0.50	0.50	0.50	0.50	1.00
Tel. sec. III	1.00	0.50	0.50	1.00	0.50	0.50
Tel. sec. IV	1.00	0.50	0.50	1.00	1.00	0.50
Tel. sec. V	1.00	1.00	0.50	1.00	1.00	0.50
Slewing range	360°					
Radius in feet	Lifting capacities in 1000 lbs					
20.0	41.8	57.0	62.0	36.4	41.8	45.0
25.0	40.0	56.0	62.0	36.4	41.8	45.0
30.0	36.0	52.0	49.0	36.2	40.8	45.0
35.0	32.2	43.6	40.4	33.4	38.0	38.6
40.0	28.8	36.8	33.6	30.2	35.6	32.2
45.0	26.2	31.4	28.4	27.8	31.2	27.2
50.0	23.8	27.0	24.0	25.6	27.0	23.2
55.0	22.0	23.4	20.6	23.6	23.6	19.8
60.0	20.2	20.4	17.6	21.8	20.6	17.0
65.0	18.6	18.0	15.2	19.6	18.2	14.4
70.0	17.4	15.8	13.0	17.4	16.0	12.4
75.0	15.8	13.8	11.0	15.6	14.2	10.6
80.0	14.2	12.2	9.4	13.8	12.6	9.0
85.0	13.2	10.8	8.0	12.4	11.2	7.6
90.0	12.0	9.4	6.8	11.2	9.8	6.4
95.0	10.6	8.4	5.6	10.0	8.8	5.2
100.0	9.4	7.2	4.6	9.0	7.6	4.2
105.0	8.4	6.2	3.6	8.0	6.8	3.2
110.0	7.4	5.2	2.6	7.0	5.8	2.4
115.0	6.6	4.4		6.2	5.0	
120.0				5.4	4.2	
125.0				4.8	3.6	
130.0				4.0	2.8	
135.0				3.4	2.4	
SLI Code	2003					
Max. permitted windspeed	12 m/s					

3 177 652

	Crane with 57 300 lbs (26 t) counterweight				
	Outrigger base - length 25.6 ft - width 16.8 ft				
	Main boom - fixed length in ft				
	165.5	166.4	181.1	181.7	196.9
Tel. sec. I	0.00	1.00	0.50	1.00	1.00
Tel. sec. II	1.00	1.00	1.00	1.00	1.00
Tel. sec. III	1.00	1.00	1.00	1.00	1.00
Tel. sec. IV	1.00	0.50	1.00	1.00	1.00
Tel. sec. V	1.00	0.50	1.00	0.50	1.00
Slewing range	360°				
Radius in feet	Lifting capacities in 1000 lbs				
25.0	29.8	35.2			
30.0	29.8	35.2	24.2	25.6	22.0
35.0	29.8	35.2	24.2	25.6	22.0
40.0	29.8	31.4	24.2	25.6	22.0
45.0	28.2	26.6	24.2	25.6	22.0
50.0	26.4	22.8	24.2	23.0	22.0
55.0	23.6	19.4	22.0	19.8	20.0
60.0	20.8	16.8	19.2	17.0	17.6
65.0	18.4	14.4	16.8	14.8	15.2
70.0	16.2	12.4	14.8	12.8	13.4
75.0	14.4	10.6	13.2	11.0	11.6
80.0	12.8	9.0	11.6	9.6	10.2
85.0	11.4	7.6	10.2	8.2	8.8
90.0	10.2	6.4	9.0	7.0	7.6
95.0	9.0	5.2	7.8	6.0	6.6
100.0	8.0	4.4	7.0	5.0	5.6
105.0	7.0	3.4	6.0	4.0	4.6
110.0	6.2	2.6	5.2	3.2	3.8
115.0	5.4		4.4	2.4	3.2
120.0	4.8		3.8		2.4
125.0	4.0		3.2		
130.0	3.4		2.6		
135.0	2.8				
140.0	2.2				
SLI Code	2003				
Max. permitted windspeed	11 m/s	10 m/s			

3 177 653

	Crane with 51 800 lbs (23.5 t) counterweight					
	Outrigger base - length 25.6 ft - width 16.8 ft					
	Main boom - fixed length in ft					
	42.3	57.5	57.6	57.8	57.9	58.0
Tel. sec. I	0.00	0.00	0.00	0.00	0.00	0.50
Tel. sec. II	0.00	0.00	0.00	0.00	0.50	0.00
Tel. sec. III	0.00	0.00	0.00	0.50	0.00	0.00
Tel. sec. IV	0.00	0.00	0.50	0.00	0.00	0.00
Tel. sec. V	0.00	0.50	0.00	0.00	0.00	0.00
Slewing range	360°					
Radius in feet	Lifting capacities in 1000 lbs					
10.0	192.0	102.0	120.0	167.0	192.0	191.0
15.0	146.0	97.0	120.0	147.0	145.0	144.0
20.0	114.0	83.0	107.0	105.0	102.0	99.0
25.0	82.0	73.0	79.0	77.0	74.0	72.0
30.0	61.0	62.0	61.0	59.0	57.0	54.0
35.0		50.0	49.0	47.0	45.0	42.8
40.0		41.0	39.8	38.4	36.6	34.4
45.0		33.6	32.4	31.0	29.2	27.2
SLI Code	1903					
Max. permitted windspeed	14 m/s					

	Crane with 51 800 lbs (23.5 t) counterweight								
	Outrigger base - length 25.6 ft - width 16.8 ft								
	Main boom - fixed length in ft								
	72.6	72.8	73.0	73.2	73.3	73.4	73.5	73.6	73.8
Tel. sec. I	0.00	0.00	0.00	0.00	0.00	0.00	0.00	0.50	1.00
Tel. sec. II	0.00	0.00	0.00	0.00	0.00	0.50	1.00	0.50	0.00
Tel. sec. III	0.00	0.00	0.00	0.50	1.00	0.50	0.00	0.00	0.00
Tel. sec. IV	0.00	0.50	1.00	0.50	0.00	0.00	0.00	0.00	0.00
Tel. sec. V	1.00	0.50	0.00	0.00	0.00	0.00	0.00	0.00	0.00
Slewing range	360°								
Radius in feet	Lifting capacities in 1000 lbs								
10.0	80.0	102.0	97.0	120.0	93.0	167.0	88.0	186.0	83.0
15.0	66.0	93.0	80.0	114.0	93.0	143.0	88.0	138.0	83.0
20.0	57.0	78.0	67.0	96.0	83.0	96.0	88.0	92.0	83.0
25.0	49.0	68.0	58.0	75.0	72.0	71.0	69.0	67.0	65.0
30.0	43.4	59.0	51.0	58.0	56.0	55.0	53.0	51.0	50.0
35.0	38.8	49.0	45.0	47.0	45.0	44.0	42.4	40.6	38.8
40.0	35.2	41.2	39.6	38.8	37.2	36.0	34.4	32.6	31.0
45.0	31.8	34.8	33.4	32.6	31.0	29.8	28.2	26.6	25.0
50.0	29.2	29.8	28.4	27.8	26.2	25.0	23.4	22.0	20.2
55.0	25.6	25.2	23.8	23.2	21.8	20.8	19.2	17.8	16.2
SLI Code	1903								
Max. permitted windspeed	14 m/s								

3 177 653

	Crane with 51 800 lbs (23.5 t) counterweight									
	Outrigger base - length 25.6 ft - width 16.8 ft									
	Main boom - fixed length in ft									
	87.9	88.3	88.8	89.1	103.3	103.9	104.5	118.8	119.0	119.6
Tel. sec. I	0.00	0.00	0.00	0.50	0.00	0.00	0.50	0.00	0.00	0.50
Tel. sec. II	0.00	0.00	0.50	0.50	0.00	0.50	0.50	0.00	0.50	0.50
Tel. sec. III	0.00	0.50	0.50	0.50	0.00	0.50	0.50	0.50	0.50	0.50
Tel. sec. IV	0.50	0.50	0.50	0.00	1.00	0.50	0.50	1.00	0.50	0.50
Tel. sec. V	1.00	0.50	0.00	0.00	1.00	0.50	0.00	1.00	1.00	0.50
Slewing range	360°									
Radius in feet	Lifting capacities in 1000 lbs									
10.0	77.0	102.0	120.0	143.0						
15.0	65.0	95.0	120.0	127.0	55.0	98.0	110.0			
20.0	56.0	81.0	92.0	87.0	47.0	86.0	84.0	48.0	61.0	81.0
25.0	48.0	71.0	69.0	65.0	41.0	68.0	63.0	43.2	56.0	62.0
30.0	42.2	58.0	54.0	50.0	36.2	54.0	50.0	38.8	50.0	50.0
35.0	37.6	47.0	44.0	40.2	31.8	44.0	40.2	35.0	44.0	40.6
40.0	33.8	39.4	36.2	32.6	28.4	37.0	33.0	31.0	37.2	33.8
45.0	30.4	33.6	30.4	26.8	25.8	31.2	27.6	28.4	31.8	28.6
50.0	27.8	28.8	25.8	22.2	23.6	26.8	23.2	26.2	27.4	24.2
55.0	25.8	25.0	22.0	18.6	21.8	23.0	19.6	24.2	23.8	20.8
60.0	23.4	21.8	18.8	15.6	20.0	20.0	16.6	22.4	20.8	17.8
65.0	20.2	18.6	16.0	13.0	18.6	17.4	14.0	20.0	18.4	15.4
70.0	17.8	16.2	13.6	10.6	17.4	15.4	12.0	17.8	16.2	13.2
75.0				8.4	16.0	13.2	10.0	15.8	14.4	11.4
80.0					14.0	11.4	8.4	14.2	12.8	9.8
85.0					12.4	9.8	6.8	12.6	11.2	8.4
90.0					11.0	8.4	5.4	11.2	9.8	7.0
95.0								10.0	8.6	5.8
100.0								8.8	7.4	4.8
SLI Code	1903									
Max. permitted windspeed	14 m/s							12 m/s		

	Crane with 51 800 lbs (23.5 t) counterweight					
	Outrigger base - length 25.6 ft - width 16.8 ft					
	Main boom - fixed length in ft					
	134.3	134.8	135.3	149.9	150.1	150.9
Tel. sec. I	0.00	0.50	1.00	0.00	0.50	1.00
Tel. sec. II	0.00	0.50	0.50	0.50	0.50	1.00
Tel. sec. III	1.00	0.50	0.50	1.00	0.50	0.50
Tel. sec. IV	1.00	0.50	0.50	1.00	1.00	0.50
Tel. sec. V	1.00	1.00	0.50	1.00	1.00	0.50
Slewing range	360°					
Radius in feet	Lifting capacities in 1000 lbs					
20.0	41.8	57.0	62.0	36.4	41.8	45.0
25.0	40.0	56.0	58.0	36.4	41.8	45.0
30.0	36.0	49.0	46.0	36.2	40.8	43.8
35.0	32.2	40.8	37.6	33.4	38.0	36.0
40.0	28.8	34.2	31.2	30.2	33.8	29.8
45.0	26.2	29.2	26.2	27.8	29.0	25.0
50.0	23.8	25.0	22.0	25.6	25.0	21.2
55.0	22.0	21.6	18.6	23.2	21.8	18.0
60.0	20.2	18.8	16.0	20.4	19.0	15.2
65.0	18.6	16.4	13.6	18.0	16.6	13.0
70.0	17.0	14.2	11.4	16.0	14.6	11.0
75.0	15.0	12.4	9.8	14.2	12.8	9.2
80.0	13.4	11.0	8.2	12.6	11.2	7.8
85.0	12.0	9.6	6.8	11.2	10.0	6.4
90.0	10.8	8.4	5.6	10.0	8.8	5.2
95.0	9.6	7.2	4.6	9.0	7.6	4.2
100.0	8.4	6.2	3.6	8.0	6.6	3.2
105.0	7.4	5.2	2.6	7.0	5.8	2.2
110.0	6.6	4.2		6.2	5.0	
115.0	5.8	3.4		5.4	4.2	
120.0				4.6	3.4	
125.0				4.0	2.8	
130.0				3.4	2.2	
135.0				2.8		
SLI Code	1903					
Max. permitted windspeed	12 m/s					

	Crane with 51 800 lbs (23.5 t) counterweight				
	Outrigger base - length 25.6 ft - width 16.8 ft				
	Main boom - fixed length in ft				
	165.5	166.4	181.1	181.7	196.9
Tel. sec. I	0.00	1.00	0.50	1.00	1.00
Tel. sec. II	1.00	1.00	1.00	1.00	1.00
Tel. sec. III	1.00	1.00	1.00	1.00	1.00
Tel. sec. IV	1.00	0.50	1.00	1.00	1.00
Tel. sec. V	1.00	0.50	1.00	0.50	1.00
Slewing range	360°				
Radius in feet	Lifting capacities in 1000 lbs				
25.0	29.8	35.2			
30.0	29.8	35.2	24.2	25.6	22.0
35.0	29.8	34.8	24.2	25.6	22.0
40.0	29.8	29.0	24.2	25.6	22.0
45.0	28.2	24.6	24.2	24.6	22.0
50.0	25.0	20.8	23.2	21.0	21.2
55.0	21.8	17.6	20.2	18.0	18.4
60.0	19.0	15.0	17.6	15.4	16.0
65.0	16.8	12.8	15.4	13.4	13.8
70.0	14.8	11.0	13.4	11.4	12.0
75.0	13.0	9.2	11.8	9.8	10.4
80.0	11.6	7.8	10.4	8.4	9.0
85.0	10.2	6.4	9.0	7.0	7.6
90.0	9.0	5.2	7.8	5.8	6.6
95.0	8.0	4.2	6.8	4.8	5.6
100.0	7.0	3.2	5.8	4.0	4.6
105.0	6.2	2.4	5.0	3.0	3.8
110.0	5.4		4.2	2.2	3.0
115.0	4.6		3.6		2.2
120.0	4.0		2.8		
125.0	3.2		2.2		
130.0	2.6				
SLI Code	1903				
Max. permitted windspeed	12 m/s	10 m/s			

3 177 654

	Crane with 46 200 lbs (21 t) counterweight					
	Outrigger base - length 25.6 ft - width 16.8 ft					
	Main boom - fixed length in ft					
	42.3	57.5	57.6	57.8	57.9	58.0
Tel. sec. I	0.00	0.00	0.00	0.00	0.00	0.50
Tel. sec. II	0.00	0.00	0.00	0.00	0.50	0.00
Tel. sec. III	0.00	0.00	0.00	0.50	0.00	0.00
Tel. sec. IV	0.00	0.00	0.50	0.00	0.00	0.00
Tel. sec. V	0.00	0.50	0.00	0.00	0.00	0.00
Slewing range	360°					
Radius in feet	Lifting capacities in 1000 lbs					
10.0	191.0	102.0	120.0	167.0	190.0	189.0
15.0	145.0	97.0	120.0	146.0	144.0	143.0
20.0	106.0	83.0	100.0	98.0	95.0	92.0
25.0	76.0	73.0	73.0	71.0	69.0	66.0
30.0	57.0	58.0	56.0	55.0	52.0	50.0
35.0		47.0	45.0	43.4	41.4	39.2
40.0		37.8	36.8	35.4	33.4	31.2
45.0		30.8	29.8	28.4	26.4	24.6
SLI Code	1803					
Max. permitted windspeed	14 m/s					

	Crane with 46 200 lbs (21 t) counterweight								
	Outrigger base - length 25.6 ft - width 16.8 ft								
	Main boom - fixed length in ft								
	72.6	72.8	73.0	73.2	73.3	73.4	73.5	73.6	73.8
Tel. sec. I	0.00	0.00	0.00	0.00	0.00	0.00	0.00	0.50	1.00
Tel. sec. II	0.00	0.00	0.00	0.00	0.00	0.50	1.00	0.50	0.00
Tel. sec. III	0.00	0.00	0.00	0.50	1.00	0.50	0.00	0.00	0.00
Tel. sec. IV	0.00	0.50	1.00	0.50	0.00	0.00	0.00	0.00	0.00
Tel. sec. V	1.00	0.50	0.00	0.00	0.00	0.00	0.00	0.00	0.00
Slewing range	360°								
Radius in feet	Lifting capacities in 1000 lbs								
10.0	80.0	102.0	97.0	120.0	93.0	167.0	88.0	186.0	83.0
15.0	66.0	93.0	80.0	114.0	93.0	134.0	88.0	129.0	83.0
20.0	57.0	78.0	67.0	93.0	83.0	90.0	87.0	85.0	83.0
25.0	49.0	68.0	58.0	70.0	68.0	66.0	64.0	62.0	60.0
30.0	43.4	57.0	51.0	54.0	52.0	51.0	49.0	47.0	45.0
35.0	38.8	46.0	44.0	43.6	41.8	40.6	38.8	37.2	35.4
40.0	35.2	38.0	36.6	35.8	34.2	33.0	31.2	29.6	27.8
45.0	31.8	32.2	30.6	30.0	28.4	27.2	25.6	24.0	22.2
50.0	27.8	27.4	26.0	25.4	23.8	22.6	21.0	19.6	17.8
55.0	23.4	23.0	21.6	21.2	19.6	18.6	17.0	15.8	14.2
SLI Code	1803								
Max. permitted windspeed	14 m/s								

3 177 654

	Crane with 46 200 lbs (21 t) counterweight									
	Outrigger base - length 25.6 ft - width 16.8 ft									
	Main boom - fixed length in ft									
	87.9	88.3	88.8	89.1	103.3	103.9	104.5	118.8	119.0	119.6
Tel. sec. I	0.00	0.00	0.00	0.50	0.00	0.00	0.50	0.00	0.00	0.50
Tel. sec. II	0.00	0.00	0.50	0.50	0.00	0.50	0.50	0.00	0.50	0.50
Tel. sec. III	0.00	0.50	0.50	0.50	0.00	0.50	0.50	0.50	0.50	0.50
Tel. sec. IV	0.50	0.50	0.50	0.00	1.00	0.50	0.50	1.00	0.50	0.50
Tel. sec. V	1.00	0.50	0.00	0.00	1.00	0.50	0.00	1.00	1.00	0.50
Slewing range	360°									
Radius in feet	Lifting capacities in 1000 lbs									
10.0	77.0	102.0	120.0	143.0						
15.0	65.0	95.0	120.0	119.0	55.0	98.0	110.0			
20.0	56.0	81.0	86.0	81.0	47.0	83.0	78.0	48.0	61.0	75.0
25.0	48.0	68.0	64.0	60.0	41.0	63.0	59.0	43.2	56.0	58.0
30.0	42.2	54.0	50.0	46.0	36.2	50.0	46.0	38.8	50.0	46.0
35.0	37.6	44.0	40.6	36.8	31.8	41.0	37.0	35.0	41.0	37.6
40.0	33.8	36.6	33.4	29.6	28.4	34.0	30.2	31.0	34.4	31.0
45.0	30.4	30.8	27.8	24.2	25.8	28.6	25.0	28.4	29.2	26.0
50.0	27.8	26.4	23.4	20.0	23.6	24.4	20.8	26.2	25.2	22.0
55.0	24.6	22.8	19.8	16.4	21.8	21.0	17.4	23.4	21.8	18.6
60.0	21.4	19.8	17.0	13.6	20.0	18.0	14.6	20.6	19.0	16.0
65.0	18.6	17.0	14.2	11.2	18.6	15.6	12.2	18.2	16.6	13.6
70.0	16.0	14.6	12.0	8.8	16.6	13.6	10.2	16.2	14.6	11.6
75.0				7.0	14.4	11.8	8.6	14.4	12.8	9.8
80.0					12.6	10.0	7.0	12.8	11.4	8.4
85.0					11.2	8.6	5.4	11.4	10.0	7.0
90.0					9.8	7.2	4.2	10.0	8.6	5.8
95.0								8.8	7.4	4.8
100.0								7.8	6.4	3.8
SLI Code	1803									
Max. permitted windspeed	14 m/s							12 m/s		

	Crane with 46 200 lbs (21 t) counterweight					
	Outrigger base - length 25.6 ft - width 16.8 ft					
	Main boom - fixed length in ft					
	134.3	134.8	135.3	149.9	150.1	150.9
Tel. sec. I	0.00	0.50	1.00	0.00	0.50	1.00
Tel. sec. II	0.00	0.50	0.50	0.50	0.50	1.00
Tel. sec. III	1.00	0.50	0.50	1.00	0.50	0.50
Tel. sec. IV	1.00	0.50	0.50	1.00	1.00	0.50
Tel. sec. V	1.00	1.00	0.50	1.00	1.00	0.50
Slewing range	360°					
Radius in feet	Lifting capacities in 1000 lbs					
20.0	41.8	57.0	62.0	36.4	41.8	45.0
25.0	40.0	56.0	53.0	36.4	41.8	45.0
30.0	36.0	46.0	42.4	36.2	40.8	40.4
35.0	32.2	37.8	34.6	33.4	37.2	33.0
40.0	28.8	31.6	28.4	30.2	31.2	27.2
45.0	26.2	26.8	23.6	27.8	26.6	22.6
50.0	23.8	22.8	19.8	24.2	22.8	19.0
55.0	22.0	19.6	16.6	21.2	19.8	16.0
60.0	19.6	17.0	14.0	18.6	17.2	13.4
65.0	17.4	14.6	11.8	16.2	15.0	11.2
70.0	15.4	12.6	9.8	14.4	13.0	9.4
75.0	13.6	11.0	8.2	12.6	11.4	7.8
80.0	12.0	9.6	6.8	11.2	10.0	6.4
85.0	10.8	8.2	5.4	10.0	8.6	5.0
90.0	9.6	7.0	4.4	8.8	7.4	4.0
95.0	8.4	6.0	3.4	7.8	6.4	3.0
100.0	7.4	5.0	2.4	6.8	5.6	
105.0	6.4	4.2		6.0	4.6	
110.0	5.6	3.4		5.2	4.0	
115.0	4.8	2.6		4.4	3.2	
120.0				3.8	2.6	
125.0				3.0		
130.0				2.4		
SLI Code	1803					
Max. permitted windspeed	12 m/s					

3 177 654

	Crane with 46 200 lbs (21 t) counterweight				
	Outrigger base - length 25.6 ft - width 16.8 ft				
	Main boom - fixed length in ft				
	165.5	166.4	181.1	181.7	196.9
Tel. sec. I	0.00	1.00	0.50	1.00	1.00
Tel. sec. II	1.00	1.00	1.00	1.00	1.00
Tel. sec. III	1.00	1.00	1.00	1.00	1.00
Tel. sec. IV	1.00	0.50	1.00	1.00	1.00
Tel. sec. V	1.00	0.50	1.00	0.50	1.00
Slewing range	360°				
Radius in feet	Lifting capacities in 1000 lbs				
25.0	29.8	35.2			
30.0	29.8	35.2	24.2	25.6	22.0
35.0	29.8	32.0	24.2	25.6	22.0
40.0	29.8	26.6	24.2	25.6	22.0
45.0	26.4	22.2	24.2	22.4	22.0
50.0	22.8	18.6	21.2	19.0	19.2
55.0	19.8	15.8	18.2	16.2	16.6
60.0	17.2	13.2	15.8	13.8	14.2
65.0	15.2	11.2	13.8	11.6	12.2
70.0	13.2	9.4	12.0	10.0	10.4
75.0	11.6	7.8	10.4	8.4	9.0
80.0	10.2	6.4	9.0	7.0	7.6
85.0	9.0	5.2	7.8	5.8	6.4
90.0	7.8	4.0	6.6	4.6	5.4
95.0	6.8	3.0	5.6	3.8	4.4
100.0	5.8	2.2	4.8	2.8	3.6
105.0	5.0		4.0		2.8
110.0	4.4		3.2		
115.0	3.6		2.6		
120.0	3.0				
125.0	2.4				
SLI Code	1803				
Max. permitted windspeed	12 m/s	10 m/s			

3 177 655

	Crane with 40 700 lbs (18.5 t) counterweight					
	Outrigger base - length 25.6 ft - width 16.8 ft					
	Main boom - fixed length in ft					
	42.3	57.5	57.6	57.8	57.9	58.0
Tel. sec. I	0.00	0.00	0.00	0.00	0.00	0.50
Tel. sec. II	0.00	0.00	0.00	0.00	0.50	0.00
Tel. sec. III	0.00	0.00	0.00	0.50	0.00	0.00
Tel. sec. IV	0.00	0.00	0.50	0.00	0.00	0.00
Tel. sec. V	0.00	0.50	0.00	0.00	0.00	0.00
Slewing range	360°					
Radius in feet	Lifting capacities in 1000 lbs					
10.0	189.0	102.0	120.0	167.0	189.0	188.0
15.0	143.0	97.0	120.0	141.0	138.0	134.0
20.0	98.0	83.0	93.0	91.0	88.0	86.0
25.0	71.0	70.0	68.0	66.0	64.0	61.0
30.0	53.0	54.0	52.0	50.0	48.0	46.0
35.0		43.0	41.6	39.8	37.8	35.6
40.0		35.0	33.8	32.2	30.2	28.2
45.0		28.4	27.2	25.6	23.8	22.0
SLI Code	1703					
Max. permitted windspeed	14 m/s					

	Crane with 40 700 lbs (18.5 t) counterweight								
	Outrigger base - length 25.6 ft - width 16.8 ft								
	Main boom - fixed length in ft								
	72.6	72.8	73.0	73.2	73.3	73.4	73.5	73.6	73.8
Tel. sec. I	0.00	0.00	0.00	0.00	0.00	0.00	0.00	0.50	1.00
Tel. sec. II	0.00	0.00	0.00	0.00	0.00	0.50	1.00	0.50	0.00
Tel. sec. III	0.00	0.00	0.00	0.50	1.00	0.50	0.00	0.00	0.00
Tel. sec. IV	0.00	0.50	1.00	0.50	0.00	0.00	0.00	0.00	0.00
Tel. sec. V	1.00	0.50	0.00	0.00	0.00	0.00	0.00	0.00	0.00
Slewing range	360°								
Radius in feet	Lifting capacities in 1000 lbs								
10.0	80.0	102.0	97.0	120.0	93.0	167.0	88.0	186.0	83.0
15.0	66.0	93.0	80.0	114.0	93.0	125.0	88.0	120.0	83.0
20.0	57.0	78.0	67.0	87.0	83.0	83.0	81.0	79.0	77.0
25.0	49.0	67.0	58.0	65.0	63.0	61.0	59.0	57.0	55.0
30.0	43.4	53.0	51.0	50.0	48.0	47.0	45.0	43.2	41.4
35.0	38.8	42.6	41.0	40.2	38.4	37.2	35.4	33.6	32.0
40.0	35.2	35.0	33.6	32.8	31.2	30.0	28.2	26.6	25.0
45.0	30.0	29.4	28.0	27.4	25.8	24.6	22.8	21.4	19.6
50.0	25.4	25.0	23.6	23.0	21.4	20.2	18.6	17.2	15.4
55.0	21.4	21.0	19.6	19.0	17.6	16.6	15.0	13.8	12.0
SLI Code	1703								
Max. permitted windspeed	14 m/s								

3 177 655

	Crane with 40 700 lbs (18.5 t) counterweight									
	Outrigger base - length 25.6 ft - width 16.8 ft									
	Main boom - fixed length in ft									
	87.9	88.3	88.8	89.1	103.3	103.9	104.5	118.8	119.0	119.6
Tel. sec. I	0.00	0.00	0.00	0.50	0.00	0.00	0.50	0.00	0.00	0.50
Tel. sec. II	0.00	0.00	0.50	0.50	0.00	0.50	0.50	0.00	0.50	0.50
Tel. sec. III	0.00	0.50	0.50	0.50	0.00	0.50	0.50	0.50	0.50	0.50
Tel. sec. IV	0.50	0.50	0.50	0.00	1.00	0.50	0.50	1.00	0.50	0.50
Tel. sec. V	1.00	0.50	0.00	0.00	1.00	0.50	0.00	1.00	1.00	0.50
Slewing range	360°									
Radius in feet	Lifting capacities in 1000 lbs									
10.0	77.0	102.0	120.0	143.0						
15.0	65.0	95.0	116.0	111.0	55.0	98.0	104.0			
20.0	56.0	81.0	80.0	75.0	47.0	77.0	72.0	48.0	61.0	70.0
25.0	48.0	64.0	60.0	56.0	41.0	59.0	54.0	43.2	56.0	54.0
30.0	42.2	50.0	46.0	42.4	36.2	46.0	42.2	38.8	46.0	42.4
35.0	37.6	40.6	37.4	33.6	31.8	37.8	33.8	35.0	38.0	34.4
40.0	33.8	33.6	30.4	26.8	28.4	31.2	27.4	31.0	31.8	28.4
45.0	30.2	28.4	25.2	21.6	25.8	26.2	22.6	28.4	26.8	23.6
50.0	25.8	24.2	21.0	17.6	23.6	22.2	18.6	24.6	23.0	19.8
55.0	22.4	20.6	17.8	14.4	21.8	19.0	15.4	21.4	19.8	16.6
60.0	19.6	17.8	15.0	11.6	19.2	16.2	12.8	18.8	17.2	14.0
65.0	16.8	15.2	12.6	9.4	17.0	14.0	10.6	16.4	15.0	12.0
70.0	14.6	13.0	10.4	7.4	15.0	12.0	8.6	14.6	13.0	10.0
75.0				5.6	13.0	10.4	7.0	12.8	11.4	8.4
80.0					11.4	8.6	5.6	11.4	10.0	7.0
85.0					9.8	7.2	4.2	10.0	8.6	5.8
90.0					8.6	6.0	3.0	8.8	7.4	4.8
95.0								7.6	6.2	3.6
100.0								6.6	5.4	2.6
SLI Code	1703									
Max. permitted windspeed	14 m/s							12 m/s		

	Crane with 40 700 lbs (18.5 t) counterweight					
	Outrigger base - length 25.6 ft - width 16.8 ft					
	Main boom - fixed length in ft					
	134.3	134.8	135.3	149.9	150.1	150.9
Tel. sec. I	0.00	0.50	1.00	0.00	0.50	1.00
Tel. sec. II	0.00	0.50	0.50	0.50	0.50	1.00
Tel. sec. III	1.00	0.50	0.50	1.00	0.50	0.50
Tel. sec. IV	1.00	0.50	0.50	1.00	1.00	0.50
Tel. sec. V	1.00	1.00	0.50	1.00	1.00	0.50
Slewing range	360°					
Radius in feet	Lifting capacities in 1000 lbs					
20.0	41.8	57.0	62.0	36.4	41.8	45.0
25.0	40.0	53.0	49.0	36.4	41.8	45.0
30.0	36.0	42.4	39.0	36.2	40.8	37.0
35.0	32.2	34.8	31.6	33.4	34.2	30.0
40.0	28.8	29.0	25.8	30.2	28.6	24.6
45.0	26.2	24.4	21.4	25.8	24.4	20.4
50.0	23.6	20.8	17.8	22.2	20.8	17.0
55.0	20.4	17.6	14.8	19.2	17.8	14.0
60.0	17.8	15.2	12.2	16.8	15.4	11.6
65.0	15.6	13.0	10.2	14.6	13.4	9.6
70.0	13.8	11.2	8.4	12.8	11.6	7.8
75.0	12.2	9.6	6.8	11.2	10.0	6.4
80.0	10.8	8.2	5.4	9.8	8.6	5.0
85.0	9.4	7.0	4.2	8.6	7.4	3.8
90.0	8.4	5.8	3.2	7.6	6.2	2.8
95.0	7.4	4.8	2.2	6.6	5.4	
100.0	6.4	4.0		5.8	4.4	
105.0	5.4	3.2		5.0	3.6	
110.0	4.6	2.4		4.2	3.0	
115.0	4.0			3.6	2.4	
120.0				2.8		
125.0				2.2		
SLI Code	1703					
Max. permitted windspeed	12 m/s					

3 177 655

	Crane with 40 700 lbs (18.5 t) counterweight				
	Outrigger base - length 25.6 ft - width 16.8 ft				
	Main boom - fixed length in ft				
	165.5	166.4	181.1	181.7	196.9
Tel. sec. I	0.00	1.00	0.50	1.00	1.00
Tel. sec. II	1.00	1.00	1.00	1.00	1.00
Tel. sec. III	1.00	1.00	1.00	1.00	1.00
Tel. sec. IV	1.00	0.50	1.00	1.00	1.00
Tel. sec. V	1.00	0.50	1.00	0.50	1.00
Slewing range	360°				
Radius in feet	Lifting capacities in 1000 lbs				
25.0	29.8	35.2			
30.0	29.8	35.2	24.2	25.6	22.0
35.0	29.8	29.2	24.2	25.6	22.0
40.0	28.4	24.0	24.2	24.0	22.0
45.0	24.2	20.0	22.4	20.2	20.4
50.0	20.8	16.6	19.2	17.0	17.4
55.0	18.0	14.0	16.4	14.4	14.8
60.0	15.6	11.6	14.2	12.0	12.6
65.0	13.6	9.6	12.2	10.2	10.6
70.0	11.8	7.8	10.6	8.4	9.0
75.0	10.2	6.4	9.0	7.0	7.6
80.0	9.0	5.0	7.8	5.8	6.4
85.0	7.8	4.0	6.6	4.6	5.2
90.0	6.6	2.8	5.6	3.6	4.2
95.0	5.6		4.6	2.6	3.2
100.0	4.8		3.8		2.4
105.0	4.0		3.0		
110.0	3.4		2.2		
115.0	2.6				
SLI Code	1703				
Max. permitted windspeed	12 m/s	10 m/s			

3 177 656

	Crane with 35 200 lbs (16 t) counterweight					
	Outrigger base - length 25.6 ft - width 16.8 ft					
	Main boom - fixed length in ft					
	42.3	57.5	57.6	57.8	57.9	58.0
Tel. sec. I	0.00	0.00	0.00	0.00	0.00	0.50
Tel. sec. II	0.00	0.00	0.00	0.00	0.50	0.00
Tel. sec. III	0.00	0.00	0.00	0.50	0.00	0.00
Tel. sec. IV	0.00	0.00	0.50	0.00	0.00	0.00
Tel. sec. V	0.00	0.50	0.00	0.00	0.00	0.00
Slewing range	360°					
Radius in feet	Lifting capacities in 1000 lbs					
10.0	188.0	102.0	120.0	167.0	187.0	186.0
15.0	142.0	97.0	120.0	131.0	127.0	124.0
20.0	91.0	83.0	86.0	84.0	81.0	79.0
25.0	65.0	64.0	63.0	61.0	58.0	56.0
30.0	48.0	49.0	48.0	46.0	43.8	41.4
35.0		39.2	37.8	36.2	34.0	31.8
40.0		32.0	30.6	29.0	27.0	24.8
45.0		25.6	24.4	23.0	21.2	19.2
SLI Code	1603					
Max. permitted windspeed	14 m/s					

	Crane with 35 200 lbs (16 t) counterweight								
	Outrigger base - length 25.6 ft - width 16.8 ft								
	Main boom - fixed length in ft								
	72.6	72.8	73.0	73.2	73.3	73.4	73.5	73.6	73.8
Tel. sec. I	0.00	0.00	0.00	0.00	0.00	0.00	0.00	0.50	1.00
Tel. sec. II	0.00	0.00	0.00	0.00	0.00	0.50	1.00	0.50	0.00
Tel. sec. III	0.00	0.00	0.00	0.50	1.00	0.50	0.00	0.00	0.00
Tel. sec. IV	0.00	0.50	1.00	0.50	0.00	0.00	0.00	0.00	0.00
Tel. sec. V	1.00	0.50	0.00	0.00	0.00	0.00	0.00	0.00	0.00
Slewing range	360°								
Radius in feet	Lifting capacities in 1000 lbs								
10.0	80.0	102.0	97.0	120.0	93.0	167.0	88.0	186.0	83.0
15.0	66.0	93.0	80.0	114.0	93.0	116.0	88.0	111.0	83.0
20.0	57.0	78.0	67.0	81.0	78.0	77.0	75.0	72.0	70.0
25.0	49.0	62.0	58.0	60.0	58.0	56.0	54.0	52.0	50.0
30.0	43.4	48.0	47.0	46.0	44.0	42.6	40.8	39.0	37.2
35.0	38.8	39.0	37.4	36.6	35.0	33.6	31.8	30.2	28.4
40.0	32.4	32.0	30.4	29.8	28.2	26.8	25.2	23.6	21.8
45.0	27.2	26.8	25.2	24.6	23.0	21.8	20.2	18.6	16.8
50.0	23.0	22.6	21.2	20.6	19.0	17.8	16.2	14.8	13.0
55.0	19.2	18.8	17.6	17.0	15.4	14.4	12.8	11.6	9.8
SLI Code	1603								
Max. permitted windspeed	14 m/s								

3 177 656

	Crane with 35 200 lbs (16 t) counterweight									
	Outrigger base - length 25.6 ft - width 16.8 ft									
	Main boom - fixed length in ft									
	87.9	88.3	88.8	89.1	103.3	103.9	104.5	118.8	119.0	119.6
Tel. sec. I	0.00	0.00	0.00	0.50	0.00	0.00	0.50	0.00	0.00	0.50
Tel. sec. II	0.00	0.00	0.50	0.50	0.00	0.50	0.50	0.00	0.50	0.50
Tel. sec. III	0.00	0.50	0.50	0.50	0.00	0.50	0.50	0.50	0.50	0.50
Tel. sec. IV	0.50	0.50	0.50	0.00	1.00	0.50	0.50	1.00	0.50	0.50
Tel. sec. V	1.00	0.50	0.00	0.00	1.00	0.50	0.00	1.00	1.00	0.50
Slewing range	360°									
Radius in feet	Lifting capacities in 1000 lbs									
10.0	77.0	102.0	120.0	143.0						
15.0	65.0	95.0	108.0	102.0	55.0	98.0	96.0			
20.0	56.0	78.0	74.0	69.0	47.0	71.0	67.0	48.0	61.0	65.0
25.0	48.0	59.0	55.0	51.0	41.0	54.0	50.0	43.2	53.0	49.0
30.0	42.2	46.0	42.4	38.4	36.2	42.6	38.4	38.8	42.4	38.8
35.0	37.6	37.2	33.8	30.0	31.8	34.6	30.6	35.0	34.8	31.2
40.0	32.6	30.6	27.4	23.8	28.4	28.4	24.6	30.6	29.0	25.6
45.0	27.6	25.6	22.6	19.0	25.8	23.6	20.0	26.0	24.4	21.2
50.0	23.4	21.8	18.8	15.2	23.0	19.8	16.2	22.4	20.8	17.6
55.0	20.2	18.6	15.6	12.2	20.0	16.8	13.2	19.4	17.8	14.6
60.0	17.6	15.8	13.0	9.6	17.4	14.4	10.8	16.8	15.2	12.2
65.0	15.0	13.4	10.8	7.6	15.2	12.2	8.8	14.8	13.2	10.2
70.0	13.0	11.4	8.8	5.8	13.2	10.4	7.0	13.0	11.4	8.4
75.0				4.0	11.6	8.8	5.4	11.4	9.8	6.8
80.0					10.0	7.2	4.2	10.0	8.4	5.6
85.0					8.6	6.0	3.0	8.8	7.4	4.4
90.0					7.4	4.8		7.6	6.2	3.4
95.0								6.6	5.2	2.4
100.0								5.6	4.2	
SLI Code	1603									
Max. permitted windspeed	14 m/s							12 m/s		

	Crane with 35 200 lbs (16 t) counterweight					
	Outrigger base - length 25.6 ft - width 16.8 ft					
	Main boom - fixed length in ft					
	134.3	134.8	135.3	149.9	150.1	150.9
Tel. sec. I	0.00	0.50	1.00	0.00	0.50	1.00
Tel. sec. II	0.00	0.50	0.50	0.50	0.50	1.00
Tel. sec. III	1.00	0.50	0.50	1.00	0.50	0.50
Tel. sec. IV	1.00	0.50	0.50	1.00	1.00	0.50
Tel. sec. V	1.00	1.00	0.50	1.00	1.00	0.50
Slewing range	360°					
Radius in feet	Lifting capacities in 1000 lbs					
20.0	41.8	57.0	59.0	36.4	41.8	45.0
25.0	40.0	49.0	45.0	36.4	41.8	42.6
30.0	36.0	38.8	35.4	36.2	38.0	33.6
35.0	32.2	31.6	28.4	32.8	31.2	27.0
40.0	28.8	26.2	23.2	27.6	26.0	22.0
45.0	24.8	22.0	19.0	23.4	22.0	18.0
50.0	21.4	18.6	15.6	20.0	18.6	14.8
55.0	18.4	15.6	12.8	17.2	16.0	12.2
60.0	16.0	13.2	10.4	15.0	13.6	9.8
65.0	14.0	11.2	8.4	13.0	11.6	8.0
70.0	12.2	9.6	6.8	11.2	10.0	6.4
75.0	10.6	8.0	5.2	9.8	8.4	4.8
80.0	9.4	6.8	4.0	8.6	7.2	3.6
85.0	8.2	5.6	2.8	7.4	6.0	2.6
90.0	7.0	4.6		6.4	5.0	
95.0	6.2	3.6		5.4	4.2	
100.0	5.2	2.8		4.6	3.4	
105.0	4.4			3.8	2.6	
110.0	3.6			3.2		
115.0	3.0			2.6		
SLI Code	1603					
Max. permitted windspeed	12 m/s					

3 177 656

	Crane with 35 200 lbs (16 t) counterweight				
	Outrigger base - length 25.6 ft - width 16.8 ft				
	Main boom - fixed length in ft				
	165.5	166.4	181.1	181.7	196.9
Tel. sec. I	0.00	1.00	0.50	1.00	1.00
Tel. sec. II	1.00	1.00	1.00	1.00	1.00
Tel. sec. III	1.00	1.00	1.00	1.00	1.00
Tel. sec. IV	1.00	0.50	1.00	1.00	1.00
Tel. sec. V	1.00	0.50	1.00	0.50	1.00
Slewing range	360°				
Radius in feet	Lifting capacities in 1000 lbs				
25.0	29.8	35.2			
30.0	29.8	32.4	24.2	25.6	22.0
35.0	29.8	26.2	24.2	25.6	22.0
40.0	25.8	21.4	23.8	21.6	21.8
45.0	21.8	17.6	20.2	18.0	18.2
50.0	18.6	14.6	17.2	15.0	15.4
55.0	16.0	12.0	14.6	12.4	13.0
60.0	13.8	9.8	12.4	10.4	10.8
65.0	11.8	8.0	10.6	8.6	9.0
70.0	10.2	6.4	9.0	7.0	7.6
75.0	8.8	5.0	7.6	5.6	6.2
80.0	7.6	3.8	6.4	4.4	5.0
85.0	6.4	2.6	5.2	3.2	4.0
90.0	5.4		4.4	2.4	3.0
95.0	4.6		3.4		2.2
100.0	3.8		2.6		
105.0	3.0				
110.0	2.4				
SLI Code	1603				
Max. permitted windspeed	12 m/s	10 m/s			

3 177 657

	Crane with 29 700 lbs (13.5 t) counterweight					
	Outrigger base - length 25.6 ft - width 16.8 ft					
	Main boom - fixed length in ft					
	42.3	57.5	57.6	57.8	57.9	58.0
Tel. sec. I	0.00	0.00	0.00	0.00	0.00	0.50
Tel. sec. II	0.00	0.00	0.00	0.00	0.50	0.00
Tel. sec. III	0.00	0.00	0.00	0.50	0.00	0.00
Tel. sec. IV	0.00	0.00	0.50	0.00	0.00	0.00
Tel. sec. V	0.00	0.50	0.00	0.00	0.00	0.00
Slewing range	360°					
Radius in feet	Lifting capacities in 1000 lbs					
10.0	187.0	102.0	120.0	167.0	186.0	185.0
15.0	136.0	97.0	120.0	121.0	118.0	115.0
20.0	84.0	82.0	80.0	78.0	75.0	72.0
25.0	59.0	59.0	58.0	56.0	53.0	51.0
30.0	44.0	45.0	43.8	41.8	39.6	37.4
35.0		35.8	34.4	32.8	30.6	28.4
40.0		29.0	27.6	26.0	24.0	22.0
45.0		23.0	21.8	20.4	18.6	16.6
SLI Code	1503					
Max. permitted windspeed	14 m/s					

	Crane with 29 700 lbs (13.5 t) counterweight								
	Outrigger base - length 25.6 ft - width 16.8 ft								
	Main boom - fixed length in ft								
	72.6	72.8	73.0	73.2	73.3	73.4	73.5	73.6	73.8
Tel. sec. I	0.00	0.00	0.00	0.00	0.00	0.00	0.00	0.50	1.00
Tel. sec. II	0.00	0.00	0.00	0.00	0.00	0.50	1.00	0.50	0.00
Tel. sec. III	0.00	0.00	0.00	0.50	1.00	0.50	0.00	0.00	0.00
Tel. sec. IV	0.00	0.50	1.00	0.50	0.00	0.00	0.00	0.00	0.00
Tel. sec. V	1.00	0.50	0.00	0.00	0.00	0.00	0.00	0.00	0.00
Slewing range	360°								
Radius in feet	Lifting capacities in 1000 lbs								
10.0	80.0	102.0	97.0	120.0	93.0	167.0	88.0	181.0	83.0
15.0	66.0	93.0	80.0	112.0	93.0	108.0	88.0	102.0	83.0
20.0	57.0	78.0	67.0	75.0	72.0	71.0	69.0	66.0	64.0
25.0	49.0	58.0	56.0	55.0	53.0	51.0	50.0	48.0	46.0
30.0	43.4	44.0	42.8	42.0	40.2	38.8	37.0	35.2	33.4
35.0	36.2	35.6	34.2	33.4	31.6	30.4	28.6	26.8	25.2
40.0	29.6	29.2	27.6	26.8	25.2	24.0	22.4	20.8	19.0
45.0	24.6	24.2	22.8	22.0	20.4	19.2	17.6	16.0	14.4
50.0	20.8	20.4	19.0	18.2	16.6	15.6	14.0	12.4	10.8
55.0	17.2	16.8	15.6	15.0	13.4	12.4	10.8	9.6	7.8
SLI Code	1503								
Max. permitted windspeed	14 m/s								

3 177 657

	Crane with 29 700 lbs (13.5 t) counterweight									
	Outrigger base - length 25.6 ft - width 16.8 ft									
	Main boom - fixed length in ft									
	87.9	88.3	88.8	89.1	103.3	103.9	104.5	118.8	119.0	119.6
Tel. sec. I	0.00	0.00	0.00	0.50	0.00	0.00	0.50	0.00	0.00	0.50
Tel. sec. II	0.00	0.00	0.50	0.50	0.00	0.50	0.50	0.00	0.50	0.50
Tel. sec. III	0.00	0.50	0.50	0.50	0.00	0.50	0.50	0.50	0.50	0.50
Tel. sec. IV	0.50	0.50	0.50	0.00	1.00	0.50	0.50	1.00	0.50	0.50
Tel. sec. V	1.00	0.50	0.00	0.00	1.00	0.50	0.00	1.00	1.00	0.50
Slewing range	360°									
Radius in feet	Lifting capacities in 1000 lbs									
10.0	77.0	102.0	120.0	143.0						
15.0	65.0	95.0	100.0	95.0	55.0	94.0	89.0			
20.0	56.0	72.0	68.0	63.0	47.0	66.0	61.0	48.0	61.0	60.0
25.0	48.0	54.0	50.0	46.0	41.0	50.0	46.0	43.2	49.0	45.0
30.0	42.2	42.2	38.8	34.8	36.2	39.0	35.0	38.8	39.0	35.4
35.0	36.0	34.0	30.8	27.0	31.8	31.4	27.6	33.6	31.8	28.4
40.0	29.8	28.0	24.8	21.0	28.4	25.8	22.0	28.0	26.4	23.0
45.0	25.0	23.2	20.2	16.6	24.6	21.2	17.6	23.8	22.0	18.8
50.0	21.2	19.6	16.6	13.0	21.0	17.8	14.2	20.4	18.6	15.4
55.0	18.2	16.6	13.6	10.2	18.0	14.8	11.4	17.4	15.8	12.8
60.0	15.8	14.0	11.2	7.8	15.6	12.6	9.0	15.2	13.6	10.4
65.0	13.4	11.8	9.2	6.0	13.4	10.6	7.0	13.2	11.6	8.6
70.0	11.4	9.8	7.2	4.2	11.8	8.8	5.4	11.4	9.8	6.8
75.0				2.6	10.2	7.4	4.0	10.0	8.4	5.4
80.0					8.6	6.0	2.8	8.6	7.2	4.2
85.0					7.4	4.8		7.6	6.0	3.2
90.0					6.2	3.8		6.4	5.0	2.2
95.0								5.4	4.0	
100.0								4.6	3.2	
SLI Code	1503									
Max. permitted windspeed	14 m/s							12 m/s		

	Crane with 29 700 lbs (13.5 t) counterweight					
	Outrigger base - length 25.6 ft - width 16.8 ft					
	Main boom - fixed length in ft					
	134.3	134.8	135.3	149.9	150.1	150.9
Tel. sec. I	0.00	0.50	1.00	0.00	0.50	1.00
Tel. sec. II	0.00	0.50	0.50	0.50	0.50	1.00
Tel. sec. III	1.00	0.50	0.50	1.00	0.50	0.50
Tel. sec. IV	1.00	0.50	0.50	1.00	1.00	0.50
Tel. sec. V	1.00	1.00	0.50	1.00	1.00	0.50
Slewing range	360°					
Radius in feet	Lifting capacities in 1000 lbs					
20.0	41.8	57.0	54.0	36.4	41.8	45.0
25.0	40.0	45.0	41.2	36.4	41.8	39.0
30.0	36.0	35.6	32.2	36.2	34.8	30.4
35.0	32.0	28.8	25.6	30.0	28.4	24.4
40.0	26.6	23.8	20.6	25.0	23.6	19.6
45.0	22.6	19.8	16.6	21.2	19.8	15.8
50.0	19.2	16.4	13.6	18.0	16.6	12.8
55.0	16.6	13.8	11.0	15.4	14.0	10.4
60.0	14.2	11.6	8.8	13.2	12.0	8.2
65.0	12.4	9.6	6.8	11.4	10.0	6.4
70.0	10.8	8.0	5.2	9.8	8.6	4.8
75.0	9.2	6.6	3.8	8.4	7.2	3.6
80.0	8.0	5.4	2.6	7.2	6.0	2.4
85.0	6.8	4.4		6.2	4.8	
90.0	6.0	3.4		5.2	3.8	
95.0	5.0	2.6		4.4	3.0	
100.0	4.2			3.6	2.2	
105.0	3.4			2.8		
110.0	2.8			2.2		
115.0	2.2					
SLI Code	1503					
Max. permitted windspeed	12 m/s					

3 177 657

	Crane with 29 700 lbs (13.5 t) counterweight				
	Outrigger base - length 25.6 ft - width 16.8 ft				
	Main boom - fixed length in ft				
	165.5	166.4	181.1	181.7	196.9
Tel. sec. I	0.00	1.00	0.50	1.00	1.00
Tel. sec. II	1.00	1.00	1.00	1.00	1.00
Tel. sec. III	1.00	1.00	1.00	1.00	1.00
Tel. sec. IV	1.00	0.50	1.00	1.00	1.00
Tel. sec. V	1.00	0.50	1.00	0.50	1.00
Slewing range	360°				
Radius in feet	Lifting capacities in 1000 lbs				
25.0	29.8	35.2			
30.0	29.8	29.4	24.2	25.6	22.0
35.0	28.0	23.6	24.2	23.6	22.0
40.0	23.4	19.2	21.6	19.2	19.4
45.0	19.8	15.6	18.0	15.8	16.2
50.0	16.8	12.6	15.2	13.0	13.4
55.0	14.2	10.2	12.8	10.6	11.2
60.0	12.2	8.2	10.8	8.8	9.2
65.0	10.4	6.4	9.0	7.0	7.6
70.0	8.8	5.0	7.6	5.6	6.2
75.0	7.4	3.6	6.2	4.2	5.0
80.0	6.2	2.4	5.2	3.2	3.8
85.0	5.2		4.2		2.8
90.0	4.2		3.2		
95.0	3.4		2.4		
100.0	2.6				
SLI Code	1503				
Max. permitted windspeed	12 m/s	10 m/s			

3 177 658

	Crane with 24 200 lbs (11 t) counterweight					
	Outrigger base - length 25.6 ft - width 16.8 ft					
	Main boom - fixed length in ft					
	42.3	57.5	57.6	57.8	57.9	58.0
Tel. sec. I	0.00	0.00	0.00	0.00	0.00	0.50
Tel. sec. II	0.00	0.00	0.00	0.00	0.50	0.00
Tel. sec. III	0.00	0.00	0.00	0.50	0.00	0.00
Tel. sec. IV	0.00	0.00	0.50	0.00	0.00	0.00
Tel. sec. V	0.00	0.50	0.00	0.00	0.00	0.00
Slewing range	360°					
Radius in feet	Lifting capacities in 1000 lbs					
10.0	185.0	102.0	120.0	167.0	185.0	183.0
15.0	124.0	97.0	113.0	111.0	107.0	104.0
20.0	76.0	74.0	72.0	70.0	68.0	65.0
25.0	53.0	54.0	52.0	50.0	48.0	45.0
30.0	39.4	40.6	39.2	37.4	35.2	32.8
35.0		32.0	30.6	28.8	26.8	24.6
40.0		25.6	24.4	22.6	20.6	18.6
45.0		20.2	19.0	17.6	15.8	13.8
SLI Code	1403					
Max. permitted windspeed	14 m/s					

	Crane with 24 200 lbs (11 t) counterweight								
	Outrigger base - length 25.6 ft - width 16.8 ft								
	Main boom - fixed length in ft								
	72.6	72.8	73.0	73.2	73.3	73.4	73.5	73.6	73.8
Tel. sec. I	0.00	0.00	0.00	0.00	0.00	0.00	0.00	0.50	1.00
Tel. sec. II	0.00	0.00	0.00	0.00	0.00	0.50	1.00	0.50	0.00
Tel. sec. III	0.00	0.00	0.00	0.50	1.00	0.50	0.00	0.00	0.00
Tel. sec. IV	0.00	0.50	1.00	0.50	0.00	0.00	0.00	0.00	0.00
Tel. sec. V	1.00	0.50	0.00	0.00	0.00	0.00	0.00	0.00	0.00
Slewing range	360°								
Radius in feet	Lifting capacities in 1000 lbs								
10.0	80.0	102.0	97.0	120.0	93.0	167.0	88.0	165.0	83.0
15.0	66.0	93.0	80.0	102.0	93.0	98.0	88.0	93.0	83.0
20.0	57.0	71.0	67.0	68.0	66.0	64.0	62.0	60.0	57.0
25.0	49.0	52.0	50.0	50.0	48.0	46.0	44.0	42.2	40.2
30.0	40.6	40.2	38.6	37.6	36.0	34.4	32.6	30.8	29.0
35.0	32.4	32.0	30.4	29.6	28.0	26.6	25.0	23.2	21.4
40.0	26.4	26.0	24.4	23.6	22.0	20.8	19.2	17.6	15.8
45.0	21.8	21.4	20.0	19.2	17.6	16.4	14.8	13.2	11.6
50.0	18.2	17.8	16.4	15.6	14.2	13.0	11.4	9.8	8.2
55.0	15.0	14.6	13.4	12.8	11.2	10.2	8.6	7.2	5.6
SLI Code	1403								
Max. permitted windspeed	14 m/s								

3 177 658

	Crane with 24 200 lbs (11 t) counterweight									
	Outrigger base - length 25.6 ft - width 16.8 ft									
	Main boom - fixed length in ft									
	87.9	88.3	88.8	89.1	103.3	103.9	104.5	118.8	119.0	119.6
Tel. sec. I	0.00	0.00	0.00	0.50	0.00	0.00	0.50	0.00	0.00	0.50
Tel. sec. II	0.00	0.00	0.50	0.50	0.00	0.50	0.50	0.00	0.50	0.50
Tel. sec. III	0.00	0.50	0.50	0.50	0.00	0.50	0.50	0.50	0.50	0.50
Tel. sec. IV	0.50	0.50	0.50	0.00	1.00	0.50	0.50	1.00	0.50	0.50
Tel. sec. V	1.00	0.50	0.00	0.00	1.00	0.50	0.00	1.00	1.00	0.50
Slewing range	360°									
Radius in feet	Lifting capacities in 1000 lbs									
10.0	77.0	102.0	120.0	143.0						
15.0	65.0	95.0	91.0	86.0	55.0	86.0	81.0			
20.0	56.0	66.0	62.0	57.0	47.0	60.0	55.0	48.0	58.0	54.0
25.0	48.0	49.0	45.0	41.2	41.0	45.0	40.8	43.2	45.0	40.8
30.0	40.2	38.2	34.6	30.6	36.2	35.0	31.0	37.0	35.2	31.6
35.0	32.4	30.6	27.2	23.4	31.6	28.0	24.0	30.4	28.6	25.0
40.0	26.8	24.8	21.6	18.0	26.0	22.8	19.0	25.2	23.4	20.0
45.0	22.4	20.4	17.4	13.8	21.8	18.6	15.0	21.2	19.4	16.2
50.0	18.8	17.0	14.0	10.6	18.6	15.4	11.8	18.0	16.4	13.2
55.0	16.0	14.2	11.4	8.0	15.8	12.8	9.2	15.4	13.8	10.6
60.0	13.6	12.0	9.2	5.8	13.6	10.6	7.0	13.2	11.6	8.6
65.0	11.6	10.0	7.2	4.0	11.6	8.6	5.2	11.4	9.8	6.8
70.0	9.8	8.2	5.6	2.6	10.0	7.0	3.8	9.8	8.2	5.2
75.0					8.6	5.8	2.4	8.4	6.8	3.8
80.0					7.2	4.6		7.2	5.6	2.8
85.0					6.0	3.4		6.2	4.6	
90.0					5.0	2.4		5.2	3.8	
95.0								4.2	2.8	
100.0								3.4		
SLI Code	1403									
Max. permitted windspeed	14 m/s							12 m/s		

	Crane with 24 200 lbs (11 t) counterweight					
	Outrigger base - length 25.6 ft - width 16.8 ft					
	Main boom - fixed length in ft					
	134.3	134.8	135.3	149.9	150.1	150.9
Tel. sec. I	0.00	0.50	1.00	0.00	0.50	1.00
Tel. sec. II	0.00	0.50	0.50	0.50	0.50	1.00
Tel. sec. III	1.00	0.50	0.50	1.00	0.50	0.50
Tel. sec. IV	1.00	0.50	0.50	1.00	1.00	0.50
Tel. sec. V	1.00	1.00	0.50	1.00	1.00	0.50
Slewing range	360°					
Radius in feet	Lifting capacities in 1000 lbs					
20.0	41.8	53.0	49.0	36.4	41.8	45.0
25.0	40.0	40.4	36.8	36.4	39.2	34.8
30.0	35.0	31.8	28.4	32.8	31.2	26.8
35.0	28.6	25.6	22.4	27.0	25.4	21.2
40.0	23.8	20.8	17.8	22.4	20.8	16.8
45.0	20.0	17.2	14.2	18.8	17.4	13.4
50.0	17.0	14.2	11.2	15.8	14.4	10.6
55.0	14.4	11.8	8.8	13.4	12.0	8.2
60.0	12.4	9.6	6.8	11.4	10.0	6.4
65.0	10.6	8.0	5.0	9.6	8.4	4.6
70.0	9.0	6.4	3.6	8.2	6.8	3.2
75.0	7.8	5.2	2.4	7.0	5.6	
80.0	6.6	4.0		5.8	4.4	
85.0	5.6	3.0		4.8	3.4	
90.0	4.6			4.0	2.6	
95.0	3.8			3.2		
100.0	3.0			2.4		
105.0	2.4					
SLI Code	1403					
Max. permitted windspeed	12 m/s					

3 177 658

	Crane with 24 200 lbs (11 t) counterweight				
	Outrigger base - length 25.6 ft - width 16.8 ft				
	Main boom - fixed length in ft				
	165.5	166.4	181.1	181.7	196.9
Tel. sec. I	0.00	1.00	0.50	1.00	1.00
Tel. sec. II	1.00	1.00	1.00	1.00	1.00
Tel. sec. III	1.00	1.00	1.00	1.00	1.00
Tel. sec. IV	1.00	0.50	1.00	1.00	1.00
Tel. sec. V	1.00	0.50	1.00	0.50	1.00
Slewing range	360°				
Radius in feet	Lifting capacities in 1000 lbs				
25.0	29.8	33.2			
30.0	29.8	26.0	24.2	25.6	22.0
35.0	25.0	20.6	23.0	20.6	20.8
40.0	20.8	16.4	19.0	16.6	17.0
45.0	17.4	13.2	15.8	13.6	13.8
50.0	14.6	10.4	13.0	10.8	11.4
55.0	12.2	8.2	10.8	8.8	9.2
60.0	10.4	6.4	9.0	6.8	7.4
65.0	8.6	4.8	7.4	5.4	6.0
70.0	7.2	3.4	6.0	4.0	4.6
75.0	6.0		4.8	2.8	3.4
80.0	4.8		3.8		2.4
85.0	3.8		2.8		
90.0	3.0				
95.0	2.2				
SLI Code	1403				
Max. permitted windspeed	12 m/s	10 m/s			

3 177 659

	Crane with 18 700 lbs (8.5 t) counterweight					
	Outrigger base - length 25.6 ft - width 16.8 ft					
	Main boom - fixed length in ft					
	42.3	57.5	57.6	57.8	57.9	58.0
Tel. sec. I	0.00	0.00	0.00	0.00	0.00	0.50
Tel. sec. II	0.00	0.00	0.00	0.00	0.50	0.00
Tel. sec. III	0.00	0.00	0.00	0.50	0.00	0.00
Tel. sec. IV	0.00	0.00	0.50	0.00	0.00	0.00
Tel. sec. V	0.00	0.50	0.00	0.00	0.00	0.00
Slewing range	360°					
Radius in feet	Lifting capacities in 1000 lbs					
10.0	184.0	102.0	120.0	167.0	183.0	181.0
15.0	114.0	97.0	104.0	101.0	98.0	94.0
20.0	69.0	68.0	66.0	64.0	61.0	58.0
25.0	48.0	49.0	47.0	45.0	42.8	40.2
30.0	35.0	36.6	35.0	33.2	31.0	28.8
35.0		28.4	27.2	25.4	23.4	21.2
40.0		22.6	21.4	19.8	17.8	15.6
45.0		17.8	16.6	15.2	13.2	11.4
SLI Code	1303					
Max. permitted windspeed	14 m/s					

	Crane with 18 700 lbs (8.5 t) counterweight								
	Outrigger base - length 25.6 ft - width 16.8 ft								
	Main boom - fixed length in ft								
	72.6	72.8	73.0	73.2	73.3	73.4	73.5	73.6	73.8
Tel. sec. I	0.00	0.00	0.00	0.00	0.00	0.00	0.00	0.50	1.00
Tel. sec. II	0.00	0.00	0.00	0.00	0.00	0.50	1.00	0.50	0.00
Tel. sec. III	0.00	0.00	0.00	0.50	1.00	0.50	0.00	0.00	0.00
Tel. sec. IV	0.00	0.50	1.00	0.50	0.00	0.00	0.00	0.00	0.00
Tel. sec. V	1.00	0.50	0.00	0.00	0.00	0.00	0.00	0.00	0.00
Slewing range	360°								
Radius in feet	Lifting capacities in 1000 lbs								
10.0	80.0	102.0	97.0	120.0	93.0	158.0	88.0	151.0	83.0
15.0	66.0	93.0	80.0	94.0	91.0	89.0	87.0	84.0	82.0
20.0	57.0	65.0	63.0	62.0	60.0	58.0	56.0	54.0	51.0
25.0	48.0	48.0	46.0	45.0	43.0	41.4	39.4	37.6	35.6
30.0	36.8	36.2	34.6	33.8	32.0	30.6	28.8	27.0	25.2
35.0	29.2	28.6	27.2	26.4	24.6	23.4	21.6	20.0	18.2
40.0	23.6	23.0	21.6	20.8	19.2	18.0	16.2	14.6	13.0
45.0	19.4	18.8	17.4	16.6	15.2	14.0	12.2	10.8	9.0
50.0	16.0	15.6	14.0	13.4	11.8	10.8	9.0	7.6	6.0
55.0	13.0	12.6	11.4	10.8	9.2	8.2	6.6	5.2	3.4
SLI Code	1303								
Max. permitted windspeed	14 m/s								

3 177 659

	Crane with 18 700 lbs (8.5 t) counterweight									
	Outrigger base - length 25.6 ft - width 16.8 ft									
	Main boom - fixed length in ft									
	87.9	88.3	88.8	89.1	103.3	103.9	104.5	118.8	119.0	119.6
Tel. sec. I	0.00	0.00	0.00	0.50	0.00	0.00	0.50	0.00	0.00	0.50
Tel. sec. II	0.00	0.00	0.50	0.50	0.00	0.50	0.50	0.00	0.50	0.50
Tel. sec. III	0.00	0.50	0.50	0.50	0.00	0.50	0.50	0.50	0.50	0.50
Tel. sec. IV	0.50	0.50	0.50	0.00	1.00	0.50	0.50	1.00	0.50	0.50
Tel. sec. V	1.00	0.50	0.00	0.00	1.00	0.50	0.00	1.00	1.00	0.50
Slewing range	360°									
Radius in feet	Lifting capacities in 1000 lbs									
10.0	77.0	102.0	120.0	132.0						
15.0	65.0	88.0	84.0	78.0	55.0	79.0	74.0			
20.0	56.0	60.0	56.0	51.0	47.0	55.0	50.0	48.0	53.0	49.0
25.0	47.0	45.0	41.0	36.8	41.0	41.0	36.6	42.6	40.6	36.6
30.0	36.4	34.4	31.0	27.0	35.2	31.6	27.4	33.6	31.8	28.2
35.0	29.4	27.4	24.0	20.2	28.4	25.0	21.0	27.4	25.6	22.0
40.0	24.0	22.0	18.8	15.2	23.4	20.0	16.2	22.6	20.8	17.4
45.0	19.8	18.0	15.0	11.4	19.4	16.2	12.6	18.8	17.2	14.0
50.0	16.6	14.8	11.8	8.4	16.4	13.2	9.6	15.8	14.2	11.0
55.0	14.0	12.2	9.4	6.0	13.8	10.8	7.2	13.4	11.8	8.8
60.0	11.8	10.2	7.2	4.0	11.8	8.8	5.2	11.4	9.8	6.8
65.0	10.0	8.4	5.6	2.4	10.0	7.0	3.6	9.6	8.2	5.2
70.0	8.2	6.8	4.0		8.4	5.6	2.2	8.2	6.6	3.8
75.0					7.2	4.4		7.0	5.4	2.4
80.0					6.0	3.2		5.8	4.4	
85.0					4.8	2.2		4.8	3.4	
90.0					3.8			4.0	2.6	
95.0								3.2		
100.0								2.4		
SLI Code	1303									
Max. permitted windspeed	14 m/s							12 m/s		

	Crane with 18 700 lbs (8.5 t) counterweight					
	Outrigger base - length 25.6 ft - width 16.8 ft					
	Main boom - fixed length in ft					
	134.3	134.8	135.3	149.9	150.1	150.9
Tel. sec. I	0.00	0.50	1.00	0.00	0.50	1.00
Tel. sec. II	0.00	0.50	0.50	0.50	0.50	1.00
Tel. sec. III	1.00	0.50	0.50	1.00	0.50	0.50
Tel. sec. IV	1.00	0.50	0.50	1.00	1.00	0.50
Tel. sec. V	1.00	1.00	0.50	1.00	1.00	0.50
Slewing range	360°					
Radius in feet	Lifting capacities in 1000 lbs					
20.0	41.8	48.0	44.0	36.4	41.8	41.2
25.0	40.0	36.6	33.0	36.4	35.6	31.0
30.0	31.8	28.6	25.2	29.6	28.0	23.8
35.0	25.8	22.8	19.6	24.2	22.6	18.4
40.0	21.4	18.4	15.2	20.0	18.4	14.4
45.0	17.8	15.0	12.0	16.6	15.2	11.2
50.0	15.0	12.2	9.2	13.8	12.4	8.6
55.0	12.6	9.8	7.0	11.6	10.2	6.4
60.0	10.6	8.0	5.0	9.8	8.4	4.6
65.0	9.0	6.4	3.6	8.2	6.8	3.2
70.0	7.6	5.0	2.2	6.8	5.4	
75.0	6.4	3.8		5.6	4.2	
80.0	5.2	2.6		4.6	3.2	
85.0	4.2			3.6	2.2	
90.0	3.4			2.8		
95.0	2.6					
SLI Code	1303					
Max. permitted windspeed	12 m/s					

3 177 659

	Crane with 18 700 lbs (8.5 t) counterweight				
	Outrigger base - length 25.6 ft - width 16.8 ft				
	Main boom - fixed length in ft				
	165.5	166.4	181.1	181.7	196.9
Tel. sec. I	0.00	1.00	0.50	1.00	1.00
Tel. sec. II	1.00	1.00	1.00	1.00	1.00
Tel. sec. III	1.00	1.00	1.00	1.00	1.00
Tel. sec. IV	1.00	0.50	1.00	1.00	1.00
Tel. sec. V	1.00	0.50	1.00	0.50	1.00
Slewing range	360°				
Radius in feet	Lifting capacities in 1000 lbs				
25.0	29.8	29.6			
30.0	27.6	22.8	24.2	22.8	22.0
35.0	22.4	18.0	20.4	18.0	18.2
40.0	18.4	14.0	16.6	14.4	14.6
45.0	15.2	11.0	13.6	11.4	11.8
50.0	12.6	8.6	11.2	9.0	9.6
55.0	10.4	6.4	9.2	7.0	7.6
60.0	8.6	4.6	7.4	5.2	6.0
65.0	7.2	3.2	6.0	3.8	4.4
70.0	5.8		4.6	2.6	3.2
75.0	4.6		3.6		2.2
80.0	3.6		2.6		
85.0	2.8				
SLI Code	1303				
Max. permitted windspeed	12 m/s	10 m/s			

3 177 670

	Crane with 13 200 lbs (6 t) counterweight					
	Outrigger base - length 25.6 ft - width 16.8 ft					
	Main boom - fixed length in ft					
	42.3	57.5	57.6	57.8	57.9	58.0
Tel. sec. I	0.00	0.00	0.00	0.00	0.00	0.50
Tel. sec. II	0.00	0.00	0.00	0.00	0.50	0.00
Tel. sec. III	0.00	0.00	0.00	0.50	0.00	0.00
Tel. sec. IV	0.00	0.00	0.50	0.00	0.00	0.00
Tel. sec. V	0.00	0.50	0.00	0.00	0.00	0.00
Slewing range	360°					
Radius in feet	Lifting capacities in 1000 lbs					
10.0	182.0	102.0	120.0	167.0	168.0	163.0
15.0	102.0	96.0	94.0	91.0	88.0	84.0
20.0	61.0	61.0	59.0	57.0	54.0	51.0
25.0	42.0	43.2	41.6	39.8	37.4	34.8
30.0	30.4	32.2	30.6	28.8	26.6	24.4
35.0		24.8	23.4	21.6	19.6	17.4
40.0		19.4	18.0	16.4	14.4	12.4
45.0		15.0	13.8	12.4	10.6	8.6
SLI Code	1203					
Max. permitted windspeed	14 m/s					

	Crane with 13 200 lbs (6 t) counterweight								
	Outrigger base - length 25.6 ft - width 16.8 ft								
	Main boom - fixed length in ft								
	72.6	72.8	73.0	73.2	73.3	73.4	73.5	73.6	73.8
Tel. sec. I	0.00	0.00	0.00	0.00	0.00	0.00	0.00	0.50	1.00
Tel. sec. II	0.00	0.00	0.00	0.00	0.00	0.50	1.00	0.50	0.00
Tel. sec. III	0.00	0.00	0.00	0.50	1.00	0.50	0.00	0.00	0.00
Tel. sec. IV	0.00	0.50	1.00	0.50	0.00	0.00	0.00	0.00	0.00
Tel. sec. V	1.00	0.50	0.00	0.00	0.00	0.00	0.00	0.00	0.00
Slewing range	360°								
Radius in feet	Lifting capacities in 1000 lbs								
10.0	80.0	102.0	97.0	120.0	93.0	143.0	88.0	136.0	83.0
15.0	66.0	88.0	80.0	85.0	82.0	80.0	78.0	75.0	72.0
20.0	57.0	58.0	56.0	55.0	53.0	51.0	49.0	47.0	45.0
25.0	43.0	42.4	40.6	39.8	37.8	36.4	34.4	32.4	30.4
30.0	32.6	32.0	30.4	29.6	27.8	26.4	24.6	22.8	21.0
35.0	25.6	25.2	23.6	22.8	21.2	19.8	18.0	16.4	14.6
40.0	20.4	20.0	18.4	17.8	16.2	14.8	13.2	11.6	9.8
45.0	16.6	16.2	14.6	14.0	12.4	11.2	9.6	8.0	6.2
50.0	13.4	13.0	11.6	11.0	9.4	8.2	6.6	5.2	3.4
55.0	11.0	10.6	9.2	8.6	7.0	6.0	4.4	3.0	
SLI Code	1203								
Max. permitted windspeed	14 m/s								

3 177 670

	Crane with 13 200 lbs (6 t) counterweight									
	Outrigger base - length 25.6 ft - width 16.8 ft									
	Main boom - fixed length in ft									
	87.9	88.3	88.8	89.1	103.3	103.9	104.5	118.8	119.0	119.6
Tel. sec. I	0.00	0.00	0.00	0.50	0.00	0.00	0.50	0.00	0.00	0.50
Tel. sec. II	0.00	0.00	0.50	0.50	0.00	0.50	0.50	0.00	0.50	0.50
Tel. sec. III	0.00	0.50	0.50	0.50	0.00	0.50	0.50	0.50	0.50	0.50
Tel. sec. IV	0.50	0.50	0.50	0.00	1.00	0.50	0.50	1.00	0.50	0.50
Tel. sec. V	1.00	0.50	0.00	0.00	1.00	0.50	0.00	1.00	1.00	0.50
Slewing range	360°									
Radius in feet	Lifting capacities in 1000 lbs									
10.0	77.0	102.0	120.0	119.0						
15.0	65.0	80.0	75.0	70.0	55.0	71.0	66.0			
20.0	56.0	54.0	50.0	45.0	47.0	49.0	44.0	48.0	48.0	43.6
25.0	42.0	39.8	36.2	31.8	40.2	36.4	32.0	38.2	36.2	32.2
30.0	32.4	30.4	27.0	23.0	31.4	27.8	23.6	30.0	28.0	24.4
35.0	25.8	24.0	20.6	16.8	25.2	21.8	17.8	24.2	22.4	19.0
40.0	21.0	19.0	16.0	12.2	20.6	17.2	13.4	19.8	18.0	14.6
45.0	17.2	15.4	12.4	8.8	17.0	13.6	10.0	16.4	14.6	11.4
50.0	14.2	12.4	9.4	6.0	14.0	11.0	7.4	13.6	12.0	8.8
55.0	11.8	10.2	7.2	3.8	11.8	8.6	5.2	11.4	9.8	6.6
60.0	9.8	8.2	5.2		9.8	6.8	3.4	9.6	8.0	4.8
65.0	8.2	6.6	3.8		8.2	5.2		8.0	6.4	3.4
70.0	6.6	5.0	2.4		6.8	3.8		6.6	5.0	
75.0					5.6	2.8		5.4	4.0	
80.0					4.6			4.4	3.0	
85.0					3.6			3.6		
90.0					2.6			2.8		
SLI Code	1203									
Max. permitted windspeed	14 m/s							12 m/s		

	Crane with 13 200 lbs (6 t) counterweight				
	Outrigger base - length 25.6 ft - width 16.8 ft				
	Main boom - fixed length in ft				
	134.3	134.8	149.9	150.1	165.5
Tel. sec. I	0.00	0.50	0.00	0.50	0.00
Tel. sec. II	0.00	0.50	0.50	0.50	1.00
Tel. sec. III	1.00	0.50	1.00	0.50	1.00
Tel. sec. IV	1.00	0.50	1.00	1.00	1.00
Tel. sec. V	1.00	1.00	1.00	1.00	1.00
Slewing range	360°				
Radius in feet	Lifting capacities in 1000 lbs				
20.0	41.8	42.8	36.4	41.2	
25.0	35.8	32.4	33.2	31.4	29.8
30.0	28.2	25.0	26.2	24.6	24.2
35.0	22.8	19.8	21.2	19.6	19.4
40.0	18.6	15.6	17.2	15.8	15.8
45.0	15.4	12.6	14.2	12.8	13.0
50.0	12.8	10.0	11.8	10.2	10.6
55.0	10.6	7.8	9.6	8.2	8.6
60.0	8.8	6.2	8.0	6.6	6.8
65.0	7.2	4.6	6.4	5.2	5.4
70.0	6.0	3.4	5.2	3.8	4.2
75.0	4.8	2.2	4.0	2.8	3.2
80.0	3.8		3.2		2.2
85.0	3.0		2.2		
90.0	2.2				
SLI Code	1203				
Max. permitted windspeed	12 m/s				

3 177 671

	Crane with 7 700 lbs (3.5 t) counterweight					
	Outrigger base - length 25.6 ft - width 16.8 ft					
	Main boom - fixed length in ft					
	42.3	57.5	57.6	57.8	57.9	58.0
Tel. sec. I	0.00	0.00	0.00	0.00	0.00	0.50
Tel. sec. II	0.00	0.00	0.00	0.00	0.50	0.00
Tel. sec. III	0.00	0.00	0.00	0.50	0.00	0.00
Tel. sec. IV	0.00	0.00	0.50	0.00	0.00	0.00
Tel. sec. V	0.00	0.50	0.00	0.00	0.00	0.00
Slewing range	360°					
Radius in feet	Lifting capacities in 1000 lbs					
10.0	181.0	102.0	120.0	156.0	151.0	146.0
15.0	91.0	86.0	84.0	82.0	78.0	75.0
20.0	54.0	54.0	52.0	50.0	48.0	45.0
25.0	36.6	38.2	36.6	34.8	32.4	29.8
30.0	26.0	28.0	26.6	24.8	22.6	20.2
35.0		21.4	20.0	18.2	16.2	14.0
40.0		16.4	15.2	13.4	11.4	9.4
45.0		12.4	11.4	9.8	8.0	6.0
SLI Code	1103					
Max. permitted windspeed	14 m/s					

	Crane with 7 700 lbs (3.5 t) counterweight								
	Outrigger base - length 25.6 ft - width 16.8 ft								
	Main boom - fixed length in ft								
	72.6	72.8	73.0	73.2	73.3	73.4	73.5	73.6	73.8
Tel. sec. I	0.00	0.00	0.00	0.00	0.00	0.00	0.00	0.50	1.00
Tel. sec. II	0.00	0.00	0.00	0.00	0.00	0.50	1.00	0.50	0.00
Tel. sec. III	0.00	0.00	0.00	0.50	1.00	0.50	0.00	0.00	0.00
Tel. sec. IV	0.00	0.50	1.00	0.50	0.00	0.00	0.00	0.00	0.00
Tel. sec. V	1.00	0.50	0.00	0.00	0.00	0.00	0.00	0.00	0.00
Slewing range	360°								
Radius in feet	Lifting capacities in 1000 lbs								
10.0	80.0	102.0	97.0	120.0	93.0	129.0	88.0	122.0	83.0
15.0	66.0	80.0	77.0	76.0	74.0	72.0	69.0	67.0	64.0
20.0	53.0	52.0	50.0	49.0	47.0	45.0	43.2	41.2	38.8
25.0	38.2	37.6	36.0	35.0	33.2	31.6	29.6	27.8	25.8
30.0	28.8	28.2	26.6	25.8	24.0	22.6	20.8	19.0	17.2
35.0	22.4	21.8	20.4	19.6	17.8	16.6	14.8	13.0	11.4
40.0	17.6	17.2	15.6	15.0	13.2	12.0	10.4	8.8	7.0
45.0	14.0	13.6	12.2	11.4	9.8	8.6	7.0	5.4	3.8
50.0	11.2	10.8	9.4	8.6	7.2	6.0	4.4	2.8	
55.0	9.0	8.6	7.2	6.6	5.0	4.0	2.2		
SLI Code	1103								
Max. permitted windspeed	14 m/s								

3 177 671

	Crane with 7 700 lbs (3.5 t) counterweight									
	Outrigger base - length 25.6 ft - width 16.8 ft									
	Main boom - fixed length in ft									
	87.9	88.3	88.8	89.1	103.3	103.9	104.5	118.8	119.0	119.6
Tel. sec. I	0.00	0.00	0.00	0.50	0.00	0.00	0.50	0.00	0.00	0.50
Tel. sec. II	0.00	0.00	0.50	0.50	0.00	0.50	0.50	0.00	0.50	0.50
Tel. sec. III	0.00	0.50	0.50	0.50	0.00	0.50	0.50	0.50	0.50	0.50
Tel. sec. IV	0.50	0.50	0.50	0.00	1.00	0.50	0.50	1.00	0.50	0.50
Tel. sec. V	1.00	0.50	0.00	0.00	1.00	0.50	0.00	1.00	1.00	0.50
Slewing range	360°									
Radius in feet	Lifting capacities in 1000 lbs									
10.0	77.0	102.0	114.0	107.0						
15.0	65.0	72.0	67.0	62.0	55.0	64.0	59.0			
20.0	51.0	48.0	44.0	39.6	47.0	43.6	38.8	45.0	42.8	38.6
25.0	37.6	35.4	31.6	27.4	36.0	32.0	27.6	34.0	32.0	28.2
30.0	28.8	26.8	23.2	19.2	27.8	24.2	20.0	26.6	24.6	21.0
35.0	22.8	20.8	17.4	13.8	22.2	18.6	14.8	21.2	19.4	16.0
40.0	18.2	16.4	13.2	9.6	17.8	14.6	10.8	17.2	15.4	12.2
45.0	14.8	13.0	9.8	6.4	14.6	11.4	7.6	14.0	12.4	9.2
50.0	12.0	10.2	7.2	3.8	12.0	8.8	5.2	11.6	9.8	6.8
55.0	9.8	8.2	5.2		9.8	6.8	3.2	9.4	7.8	4.8
60.0	8.0	6.4	3.4		8.0	5.0		7.8	6.2	3.2
65.0	6.6	4.8			6.6	3.6		6.4	4.8	
70.0	5.2	3.6			5.2	2.4		5.0	3.6	
75.0					4.2			4.0	2.4	
80.0					3.2			3.0		
85.0					2.4			2.2		
SLI Code	1103									
Max. permitted windspeed	14 m/s							12 m/s		

	Crane with 7 700 lbs (3.5 t) counterweight				
	Outrigger base - length 25.6 ft - width 16.8 ft				
	Main boom - fixed length in ft				
	134.3	134.8	149.9	150.1	165.5
Tel. sec. I	0.00	0.50	0.00	0.50	0.00
Tel. sec. II	0.00	0.50	0.50	0.50	1.00
Tel. sec. III	1.00	0.50	1.00	0.50	1.00
Tel. sec. IV	1.00	0.50	1.00	1.00	1.00
Tel. sec. V	1.00	1.00	1.00	1.00	1.00
Slewing range	360°				
Radius in feet	Lifting capacities in 1000 lbs				
20.0	41.6	38.0	36.4	36.6	
25.0	31.8	28.4	29.4	27.8	27.0
30.0	24.8	21.6	23.0	21.4	21.2
35.0	20.0	16.8	18.4	16.8	16.8
40.0	16.2	13.2	14.8	13.4	13.4
45.0	13.2	10.2	12.0	10.6	10.8
50.0	10.8	8.0	9.8	8.4	8.6
55.0	8.8	6.0	7.8	6.4	6.8
60.0	7.0	4.4	6.2	4.8	5.2
65.0	5.6	3.0	5.0	3.6	4.0
70.0	4.4		3.8	2.4	2.8
75.0	3.4		2.8		
80.0	2.6				
SLI Code	1103				
Max. permitted windspeed	12 m/s				

3 177 672

	Crane with 2 200 lbs (1 t) counterweight					
	Outrigger base - length 25.6 ft - width 16.8 ft					
	Main boom - fixed length in ft					
	42.3	57.5	57.6	57.8	57.9	58.0
Tel. sec. I	0.00	0.00	0.00	0.00	0.00	0.50
Tel. sec. II	0.00	0.00	0.00	0.00	0.50	0.00
Tel. sec. III	0.00	0.00	0.00	0.50	0.00	0.00
Tel. sec. IV	0.00	0.00	0.50	0.00	0.00	0.00
Tel. sec. V	0.00	0.50	0.00	0.00	0.00	0.00
Slewing range	360°					
Radius in feet	Lifting capacities in 1000 lbs					
10.0	171.0	102.0	120.0	139.0	135.0	130.0
15.0	81.0	77.0	75.0	72.0	69.0	65.0
20.0	47.0	48.0	46.0	43.8	41.2	38.4
25.0	31.2	33.2	31.6	29.8	27.4	24.8
30.0	21.6	24.0	22.6	20.8	18.6	16.2
35.0		17.8	16.6	14.8	12.8	10.6
40.0		13.4	12.2	10.6	8.6	6.4
45.0		10.0	8.8	7.2	5.4	3.2
SLI Code	1003					
Max. permitted windspeed	14 m/s					

	Crane with 2 200 lbs (1 t) counterweight								
	Outrigger base - length 25.6 ft - width 16.8 ft								
	Main boom - fixed length in ft								
	72.6	72.8	73.0	73.2	73.3	73.4	73.5	73.6	73.8
Tel. sec. I	0.00	0.00	0.00	0.00	0.00	0.00	0.00	0.50	1.00
Tel. sec. II	0.00	0.00	0.00	0.00	0.00	0.50	1.00	0.50	0.00
Tel. sec. III	0.00	0.00	0.00	0.50	1.00	0.50	0.00	0.00	0.00
Tel. sec. IV	0.00	0.50	1.00	0.50	0.00	0.00	0.00	0.00	0.00
Tel. sec. V	1.00	0.50	0.00	0.00	0.00	0.00	0.00	0.00	0.00
Slewing range	360°								
Radius in feet	Lifting capacities in 1000 lbs								
10.0	80.0	102.0	97.0	120.0	93.0	115.0	88.0	108.0	83.0
15.0	66.0	71.0	69.0	68.0	65.0	63.0	61.0	58.0	55.0
20.0	47.0	46.0	44.0	43.2	41.0	39.4	37.2	35.2	32.8
25.0	33.6	33.0	31.2	30.4	28.4	27.0	25.0	23.0	21.0
30.0	25.0	24.4	22.8	22.0	20.2	18.8	17.0	15.2	13.2
35.0	19.0	18.6	17.0	16.2	14.6	13.2	11.6	9.8	8.0
40.0	14.8	14.2	12.8	12.0	10.4	9.2	7.6	5.8	4.2
45.0	11.6	11.0	9.6	8.8	7.4	6.2	4.4	3.0	
50.0	9.0	8.6	7.0	6.4	4.8	3.8			
55.0	7.0	6.6	5.0	4.4	3.0				
SLI Code	1003								
Max. permitted windspeed	14 m/s								

3 177 672

	Crane with 2 200 lbs (1 t) counterweight									
	Outrigger base - length 25.6 ft - width 16.8 ft									
	Main boom - fixed length in ft									
	87.9	88.3	88.8	89.1	103.3	103.9	104.5	118.8	119.0	119.6
Tel. sec. I	0.00	0.00	0.00	0.50	0.00	0.00	0.50	0.00	0.00	0.50
Tel. sec. II	0.00	0.00	0.50	0.50	0.00	0.50	0.50	0.00	0.50	0.50
Tel. sec. III	0.00	0.50	0.50	0.50	0.00	0.50	0.50	0.50	0.50	0.50
Tel. sec. IV	0.50	0.50	0.50	0.00	1.00	0.50	0.50	1.00	0.50	0.50
Tel. sec. V	1.00	0.50	0.00	0.00	1.00	0.50	0.00	1.00	1.00	0.50
Slewing range	360°									
Radius in feet	Lifting capacities in 1000 lbs									
10.0	77.0	102.0	102.0	95.0						
15.0	65.0	64.0	60.0	54.0	55.0	57.0	51.0			
20.0	45.0	42.8	38.6	34.0	42.6	38.4	33.6	39.8	37.8	33.6
25.0	33.2	31.0	27.2	23.0	31.6	27.8	23.4	30.0	28.0	24.2
30.0	25.0	23.0	19.6	15.6	24.2	20.6	16.4	23.2	21.2	17.6
35.0	19.6	17.6	14.4	10.6	19.0	15.6	11.6	18.2	16.4	13.0
40.0	15.4	13.6	10.4	6.8	15.2	11.8	8.0	14.6	12.8	9.6
45.0	12.4	10.6	7.4	4.0	12.2	9.0	5.2	11.8	10.0	6.8
50.0	9.8	8.0	5.0		9.8	6.6	3.0	9.4	7.8	4.6
55.0	7.8	6.2	3.2		7.8	4.8		7.6	6.0	2.8
60.0	6.2	4.6			6.2	3.2		6.0	4.4	
65.0	4.8	3.2			4.8			4.8	3.2	
70.0	3.6				3.8			3.6		
75.0					2.8			2.6		
SLI Code	1003									
Max. permitted windspeed	14 m/s							12 m/s		

	Crane with 2 200 lbs (1 t) counterweight				
	Outrigger base - length 25.6 ft - width 16.8 ft				
	Main boom - fixed length in ft				
	134.3	134.8	149.9	150.1	165.5
Tel. sec. I	0.00	0.50	0.00	0.50	0.00
Tel. sec. II	0.00	0.50	0.50	0.50	1.00
Tel. sec. III	1.00	0.50	1.00	0.50	1.00
Tel. sec. IV	1.00	0.50	1.00	1.00	1.00
Tel. sec. V	1.00	1.00	1.00	1.00	1.00
Slewing range	360°				
Radius in feet	Lifting capacities in 1000 lbs				
20.0	37.0	33.2	33.8	32.0	
25.0	28.0	24.6	25.6	24.0	23.4
30.0	21.6	18.4	19.8	18.2	18.0
35.0	17.0	14.0	15.6	14.2	14.2
40.0	13.6	10.6	12.4	10.8	11.0
45.0	10.8	8.0	9.8	8.4	8.6
50.0	8.6	5.8	7.8	6.4	6.6
55.0	6.8	4.2	6.0	4.6	5.0
60.0	5.4	2.6	4.6	3.2	3.6
65.0	4.2		3.4		2.4
70.0	3.0		2.2		
SLI Code	1003				
Max. permitted windspeed	12 m/s				

Regional Headquarters

Americas

Manitowoc, Wisconsin, USA

Tel: +1 920 684 6621

Fax: +1 920 683 6278

Shady Grove, Pennsylvania, USA

Tel: +1 717 597 8121

Fax: +1 717 597 4062

Regional Offices

Americas

Brazil

Alphaville

Tel: +55 11 3103 0200

Fax: +55 11 4688 2013

Mexico

Monterrey

Tel: +52 81 8124 0128

Fax: +52 81 8124 0129

Europe, Middle East, Africa

Algeria

Hydra

Tel: +21 3 21 48 1173

Fax: +21 3 21 48 1454

Czech Republic

Netvorice

Tel: +420 317 78 9313

Fax: +420 317 78 9314

France

Baudemont

Tel: +33 385 28 2589

Fax: +33 385 28 0430

Cergy

Tel: +33 130 31 3150

Fax: +33 130 38 6085

Decines

Tel: +33 472 81 5000

Fax: +33 472 81 5010

Germany

Langenfeld

Tel: +49 21 73 8909-0

Fax: +49 21 73 8909 30

Hungary

Budapest

Tel: +36 13 39 8622

Fax: +36 13 39 8622

Italy

Parabiago

Tel: +390 331 49 3311

Fax: +390 331 49 3330

Europe, Middle East, Africa

Ecully, France

Tel: +33 472 18 2020

Fax: +33 472 18 2000

Netherlands

Breda

Tel: +31 76 578 3999

Fax: +31 76 578 3978

Poland

Warsaw

Tel: +48 22 843 3824

Fax: +48 22 843 3471

Portugal

Alfena

Tel: +351 229 69 8840

Fax: +351 229 69 8848

Lisbon

Tel: +351 212 109 340

Fax: +351 212 109 349

Russia

Moscow

Tel: +7 495 641 2359

Fax: +7 495 641 2358

U.A.E.

Dubai

Tel: +971 4 3381 861

Fax: +971 4 3382 343

U. K.

Middlesex

Tel: +44 1 895 43 0053

Fax: +44 1 895 45 9500

Sunderland

Tel: +44 191 522 2000

Fax: +44 191 522 2052

Asia – Pacific

Australia

Melbourne

Tel: +61 3 9 336 1300

Fax: +61 3 9 336 1322

Sydney

Tel: +61 2 9 896 4433

Fax: +61 2 9 896 3122

Asia – Pacific

Shanghai, China

Tel: +86 21 51113579

Fax: +86 21 51113578

Singapore

Tel: +65 6264 1188

Fax: +65 6862 4142

China

Beijing

Tel: +86 10 58674761

Fax: +86 10 58674760

Xi'an

Tel: +86 29 87891465

Fax: +86 29 87884504

Korea

Seoul

Tel: +82 2 3439 0400

Fax: +82 2 3439 0405

Philippines

Makati City

Tel: +63 2 844 9437

Fax: +63 2 844 4712

Factories

Brazil

Alphaville

China

Zhangjiagang

France

Charlieu

La Clayette

Moulins

Germany

Wilhelmshaven

India

Calcutta

Pune

Italy

Niella Tanaro

Portugal

Baltar

Fânzeres

Slovakia

Saris

U.S.A.

Manitowoc

Port Washington

Shady Grove



Constant improvement and engineering progress make it necessary that we reserve the right to make specification, equipment and price changes without notice. Illustrations shown may include optional equipment and accessories, and may not include all standard equipment.