

GUAY

SHUTTLELIFT®

Carrydeck® Industrial Cranes

DIMENSIONAL DATA

U.S. (METRIC)

A. Overall length - transport position	
5540	21'6" (6.55 m)
5550RT	19'8" (5.99 m)
5560RT	22'8" (6.91 m)
B. Overall length of frame.....	14'1.25" (4.30 m)
C. \varnothing rotation to \varnothing front of frame.....	7'1.25" (2.17 m)
D. \varnothing rotation to \varnothing front outrigger.....	6'8" (2.03 m)
E. \varnothing rotation to \varnothing rear outrigger	6'6.75" (2.00 m)
F. Wheelbase	7'11.25" (2.42 m)
G. \varnothing rotation to \varnothing rear axle	3'11" (1.19 m)
H. Ground line to first step.....	1'4.5" (0.42 m)
I. Ground line to center of axle	1'8" (0.51 m)
J. Outrigger clearance	13.25" (0.34 m)
K. \varnothing rotation to boom pivot pin.....	3'6" (1.07 m)
L. Tail swing	6'0" (1.83 m)

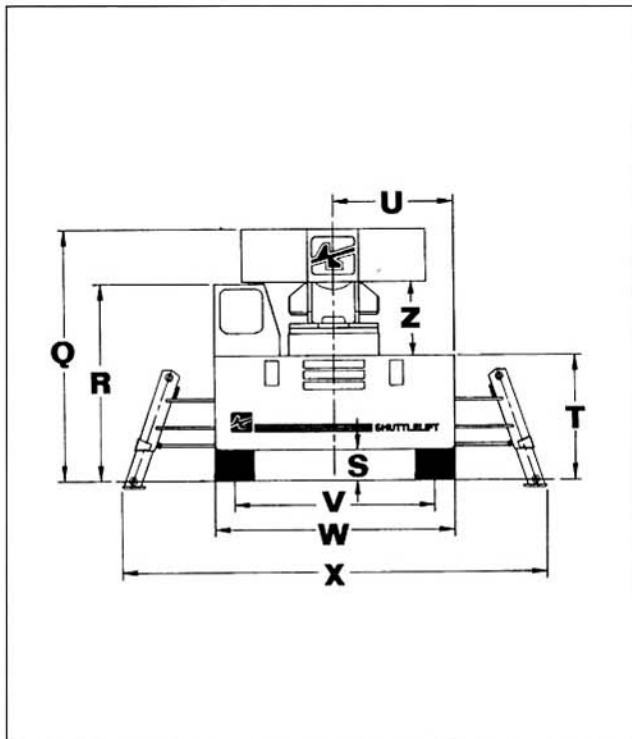
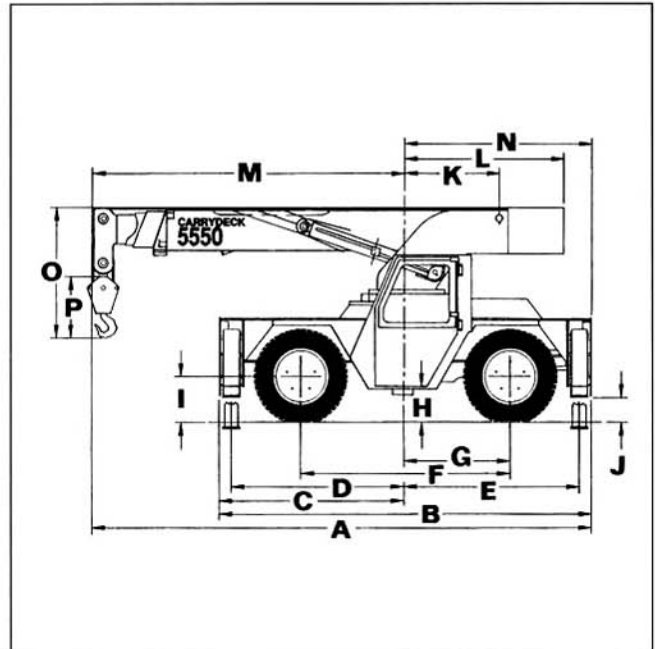

M. \varnothing rotation to tip of head section	
5540	14'6" (4.42 m)
5550RT	12'8" (3.86 m)
5560RT	15'8" (4.78 m)
N. \varnothing rotation to rear of deck.....	7'0" (2.13 m)
O. Boom end height	5'3" (1.60 m)
P. Length of hook block.....	2'3" (0.69 m)
Q. Overall height - travel position.....	7'11" (2.41 m)
R. Height to top of cab.....	6'2.25" (1.89 m)
S. Ground clearance	14.25" (0.36 m)
T. Deck height:	
On standard tires	3'10" (1.17 m)
On outriggers.....	4'7.75" (1.24 m)
U. \varnothing rotation to side of deck.....	3'10.75" (1.19 m)
V. Wheel tread.....	6'6" (1.98 m)
W. Frame width	7'9.5" (2.38 m)
X. Overall width - outriggers extended.....	13'10" (4.22 m)
Y. Overall width - outriggers retracted and down.....	8'7" (2.62 m)
(Dimension not shown)	
Z. Underside of c/wt to deck.....	2'5.5" (.75 m)

Note: All dimensions with standard tires unless otherwise noted.

5500 Series Dimensions and Specifications

Models 5540, 5550RT & 5560RT

OPERATING DATA 5500 Series

1. The rated loads are the maximum lift capacities as determined by operating radius, boom length and boom angle. The operating radius is the horizontal distance from a projection of the axis of rotation to the supporting surface, before loading, to the center of the vertical hoist line or tackle with load applied.

2. The rated loads shown on outriggers do not exceed 85% of actual tipping. The rated loads shown on rubber do not exceed 75% of actual tipping. These ratings are based on freely suspended loads with the crane leveled, standing on a firm, uniform supporting surface. Practical working loads depend on supporting surface, operating radius and other factors affecting stability. Hazardous surroundings, climactic conditions, experience of personnel and proper handling must all be taken into account by the operator.

3. The weights of all load handling devices, such as hooks, hook blocks, slings, etc., except the hoist rope, shall be included as part of the load.

4. Ratings on outriggers are for either outriggers fully extended and down or fully retracted and down. Ratings for outriggers fully retracted and down will apply for any intermediate outrigger setting.

5. Ratings on rubber depend on tire capacity, condition of tires and proper inflation pressure of 120 psi (827.4 kPa). Loads on rubber may be transported at a maximum speed of 2.5 mph (4 km/h) on a smooth, hard, level surface with boom retracted to the shortest length possible and centered over front. Do not use jib with crane on rubber.

6. For operating radius not shown, use load rating of next larger radius.

7. The maximum combined total boom and deck load is 16,000 lb (7258 kg). The maximum deck load is 20,000 lb (9072 kg).

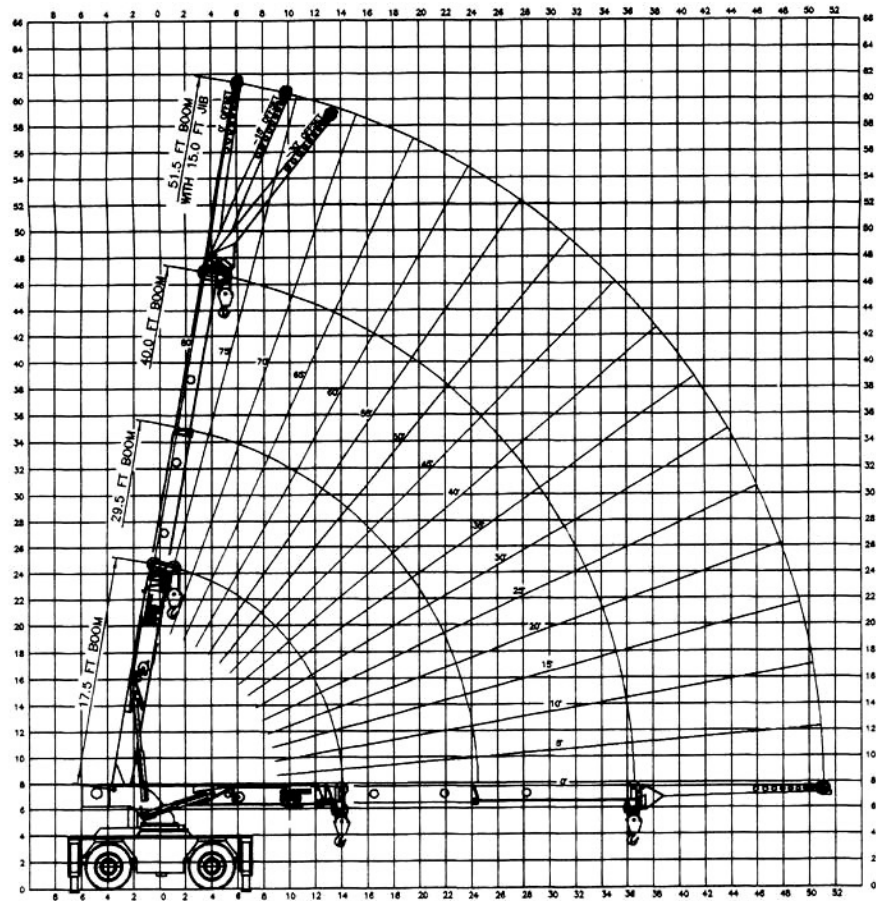

5540 3-SECTION BOOM WITH 15' (4.6M) JIB

15 ton (13.6 metric ton) main block, 210 lb (95.3 kg), and 5 ton (4.5 metric ton) ball and hook, 94 lb (42.6 kg)

8. Do not induce any external side loads to boom or jib.

9. Operate jib with outriggers fully extended and down.

10. For front or rear ratings on outriggers retracted and down, use 360° ratings on outriggers extended and down.

11. For 360° ratings on rubber, rear axle oscillation lock must be engaged.

12. For all boom lengths less than the maximum, ratings are determined by boom angle only in appropriate column.

13. Operation of this equipment in excess of rating charts and disregard of instructions is dangerous and voids warranty.

14. Shaded areas are governed by structural strength. Do not rely on tipping.

15. Ratings on main boom assume the jib to be in the side stowed position.

RATED LOAD CAPACITIES 5540

Operating Radius	*On Extended and Down Outriggers Less Jib 360° or Retracted and Down Front /Rear **On Retracted and Down Outriggers Less Jib 360°										On Rubber Less Jib 360°	
	17.5' Boom			29.5' Boom			40.0' Boom			Any Boom Length		
	Boom Angle	*Rated Load	**Rated Load	Boom Angle	*Rated Load	** Rated Load	Boom Angle	*Rated Load	**Rated Load	Front Rating	360° Rating	
6' (1.8 m)	63°	30,000 lb (13,608 kg)	30,000 lb (13,608 kg)	74°	29,100 lb (13,200 kg)	29,100 lb (13,200 kg)	79°	25,500 lb (11,567 kg)	25,500 lb (11,567 kg)	16,000 lb (7258 kg)	10,900 lb (4944 kg)	
8' (2.4 m)	55°	29,600 lb (13,427 kg)	27,200 lb (12,338 kg)	70°	28,600 lb (12,973 kg)	28,000 lb (12,701 kg)	76°	24,200 lb (10,977 kg)	24,200 lb (10,977 kg)	13,100 lb (5942 kg)	8,700 lb (3946 kg)	
10' (3.0 m)	45°	23,200 lb (10,524 kg)	17,000 lb (7711 kg)	66°	23,600 lb (10,705 kg)	16,600 lb (7530 kg)	73°	21,400 lb (9707 kg)	17,000 lb (7711 kg)	10,800 lb (4899 kg)	7,100 lb (3221 kg)	
12' (3.7 m)	34°	18,900 lb (8573 kg)	12,000 lb (5443 kg)	62°	19,300 lb (8755 kg)	11,500 lb (5216 kg)	70°	18,800 lb (8528 kg)	12,800 lb (5806 kg)	8,900 lb (4037 kg)	5,950 lb (2699 kg)	
14' (4.3 m)	11°	15,900 lb (7212 kg)	9,100 lb (4128 kg)	57°	16,300 lb (7394 kg)	8,700 lb (3946 kg)	66°	16,400 lb (7439 kg)	9400 lb (4264 kg)	7,100 lb (3221 kg)	5,000 lb (2268 kg)	
16' (4.9 m)	-	-	-	52°	14,000 lb (6350 kg)	7,200 lb (3266 kg)	63°	14,200 lb (6441 kg)	7,450 lb (3379 kg)	5,850 lb (2654 kg)	4,200 lb (1905 kg)	
18' (5.5 m)	-	-	-	47°	11,750 lb (5330 kg)	6,000 lb (2722 kg)	60°	12,000 lb (5443 kg)	5,900 lb (2676 kg)	4,800 lb (2177 kg)	3,500 lb (1588 kg)	
20' (6.1 m)	-	-	-	41°	9,850 lb (4468 kg)	4,900 lb (2223 kg)	56°	10,000 lb (4536 kg)	4,900 lb (2223 kg)	3,950 lb (1792 kg)	2850 lb (1293 kg)	
22' (6.7 m)	-	-	-	34°	8,400 lb (3810 kg)	4,000 lb (1814 kg)	53°	8,500 lb (3856 kg)	4,080 lb (1851 kg)	3,300 lb (1497 kg)	2350 lb (1066 kg)	
24' (7.3 m)	-	-	-	25°	7,200 lb (3266 kg)	3,350 lb (1520 kg)	49°	7,300 lb (3311 kg)	3,500 lb (1588 kg)	2,750 lb (1247 kg)	1,960 lb (889 kg)	
26' (7.9 m)	-	-	-	7°	6,300 lb (2858 kg)	2,850 lb (1293 kg)	45°	6,400 lb (2903 kg)	3,000 lb (1361 kg)	2,400 lb (1089 kg)	1,680 lb (762 kg)	
28' (8.5 m)	-	-	-	-	-	-	40°	5,650 lb (2563 kg)	2,600 lb (1179 kg)	2,050 lb (930 kg)	1,400 lb (635 kg)	
30' (9.1 m)	-	-	-	-	-	-	36°	5,000 lb (2268 kg)	2,300 lb (1043 kg)	1,850 lb (839 kg)	1,200 lb (544 kg)	
32' (9.8 m)	-	-	-	-	-	-	30°	4,500 lb (2041 kg)	1,950 lb (885 kg)	1,600 lb (726 kg)	1000 lb (454 kg)	
34' (10.4 m)	-	-	-	-	-	-	23°	4,000 lb (1814 kg)	1,800 lb (817 kg)	1,400 lb (635 kg)	850 lb (386 kg)	
36.5' (11.1 m)	-	-	-	-	-	-	5°	3,550 lb (1610 kg)	1,500 lb (680 kg)	1,200 lb (544 kg)	670 lb (304 kg)	

Shaded areas are governed by structural strength. Do not rely on tipping.

For 360° rating on rubber, rear axle locks must be in place.

15' (4.6 m) Jib Capacities on Outriggers							
Main Boom Angle	Jib Offset Angle			Main Boom Angle	Jib Offset Angle		
	0°	15°	30°		0°	15°	30°
80°	-	5,000 lb (2268 kg)	3,500 lb (1588 kg)	35°	2,600 lb (1179 kg)	2,150 lb (975 kg)	1,900 lb (862 kg)
75°	*7,500 lb (3402 kg)	4,400 lb (1996 kg)	3,100 lb (1406 kg)	30°	2,400 lb (1089 kg)	2,080 lb (944 kg)	1,850 lb (839 kg)
70°	*6,100 lb (2767 kg)	3,900 lb (1769 kg)	2,800 lb (1270 kg)	25°	2,300 lb (1043 kg)	2,050 lb (930 kg)	-
65°	5,000 lb (2268 kg)	3,500 lb (1588 kg)	2,550 lb (1157 kg)	20°	2,200 lb (998 kg)	2,000 lb (907 kg)	-
60°	4,300 lb (1951 kg)	3,150 lb (1429 kg)	2,350 lb (1066 kg)	15°	2,100 lb (953 kg)	1,950 lb (885 kg)	-
55°	3,800 lb (1724 kg)	2,850 lb (1293 kg)	2,200 lb (998 kg)	10°	2,050 lb (930 kg)	-	-
50°	3,400 lb (1542 kg)	2,600 lb (1179 kg)	2,100 lb (953 kg)	5°	2,020 lb (916 kg)	-	-
45°	3,050 lb (1384 kg)	2,400 lb (1089 kg)	2,000 lb (907 kg)	0°	2,000 lb (907 kg)	-	-
40°	2,800 lb (1270 kg)	2,250 lb (1021 kg)	1,950 lb (885 kg)				

Shaded areas are governed by structural strength. Do not rely on tipping.

Jib loads must not exceed main boom capacity.

*Do not exceed 29.5' (9 m) main boom length.

Rating reduction for load handling devices installed.
Main block 210 lbs. (95.3 kg), hook & ball 94 lbs. (42.6 kg)

SPECIFICATIONS 5500 Series

GENERAL INFORMATION

Unit weight (approx.)

5540	26,500 lb (12,020 kg)
5550RT	29,000 lb (13,154 kg)
5560RT	30,700 lb (13,926 kg)
Boom elevation	0° to 80°
Outrigger pad size	8.75" x 10" (222 mm x 254 mm)

SERVICE CAPACITIES

Fuel tank	40 gal (151.4 L)
Hydraulic system	30 gal (113.6 L)
Hydraulic reservoir	40 gal (151.4 L)
Cooling system	23 qt (21.8 L)
Transmission	4 gal (15.1 L)
Differential:	
Front axle -- center ...	24.5 qt (23.2 L)
hubs (per hub)	1.6 qt (1.5 L)
Rear axle -- center	19 qt (18 L)
hubs (per hub)	1.8 qt (1.7 L)

WINCHES

Main winch:

Drum diameter	9.75" (248 mm)
Wire rope diameter	1/2" (12.7 mm)
Wire rope length	250' (76.20 m)
Line speed	225 fpm (68.6 m/min)
Line pull, bare drum	12,000 lb (5443 kg)

NOTE: Maximum permissible
single line pull 7,500 lb (3402 kg)

Recessed winch (optional):

Drum diameter	4" (102 mm)
Wire rope diameter	7/16" (11 mm)
Wire rope length	115' (35 m)
Line speed, first layer	26 fpm (7.9 m/min)
Line pull, bare drum	10,000 lb (4536 kg)

STANDARD EQUIPMENT

Hydraulic boom:

5540	3-section 14'0" to 37'2" (4.3 m to 11.3 m) from center of rotation
5550RT	4-section 12'2" to 40'8" (3.7 m to 12.4 m) from center of rotation
5560RT	4-section 15'2" to 50'6" (4.6 m to 15.4 m) from center of rotation

- 4-wheel steer with crab steering
- 4-speed power shift transmission
- Power steering and power brakes
- Oscillating rear axle (4°)
(with 4-wheel drive only)
- Boom angle indicator (2)

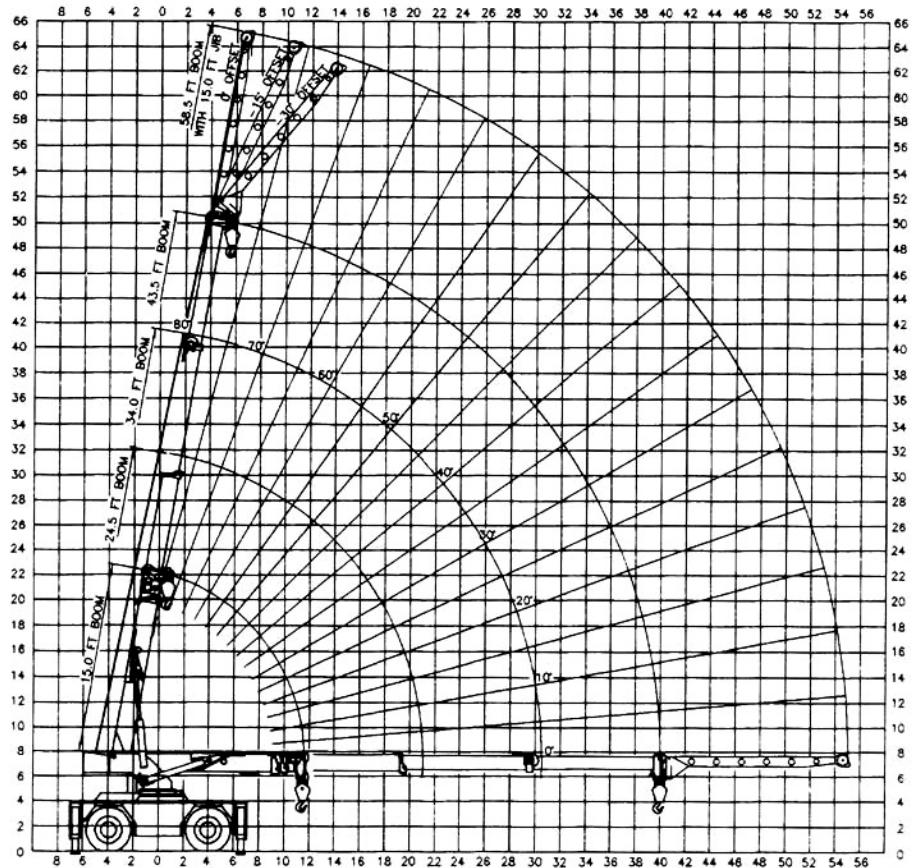

5550RT 4-SECTION BOOM WITH 15' (4.6M) JIB

15 ton (13.6 metric ton) main block, 210 lb (95.3 kg), and 5 ton (4.5 metric ton) ball and hook, 94 lb (42.6 kg)

- Double blocking crowd out, winch in and luff down kickout
- Electric horn
- Lights-head, tail, rear, work, stop and turn signals
- Engine hourmeter
- All steel cab structure
- Adjustable operator's seat with seatbelt
- Engine:
 - 5540
 - 5550RT
- 15 ton (13,600 kg) doublesheave hoistblock
- All load carrying cylinders include load hold check valves
- Built-in tool box
- Lighted instrument gauges
- 80° boom elevation
- Front and rear tie down lug
- 4-wheel drive (5550RT & 5560RT)

5540	Cummins 4B3.9 76hp @ 2500 rpm
5550RT & 5560RT ..	Cummins 4BT3.9 110hp @ 2500 rpm

- Backup alarm
- 1/2" (12.7 mm) diameter 6x19 EIPS-IWRC wire rope 250' (76.20 m)
- Tires-15.00 x 22.5 radial, high traction
- Outrigger-hydraulic telescoping box-front and rear with independent control for each side

OPTIONAL EQUIPMENT

- Enclosed cab with windshield wiper
- Suspension seat
- GM 4.3L V-6 dual fuel gas
- Four independent outrigger controls
- Cummins 4BT3.9 diesel (5540)
- Four wheel drive on 5540
(standard on 5550RT & 5560RT)

RATED LOAD CAPACITIES 5550RT

Operating Radius	*On Extended and Down Outriggers Less Jib 360° or Retracted and Down Front /Rear **On Retracted and Down Outriggers Less Jib 360°												On Rubber Less Jib 360°		
	15.0' Boom			24.5' Boom			34.0' Boom			43.5' Boom			Any Boom Length		
	Boom Angle	*Rated Load	**Rated Load	Boom Angle	*Rated Load	**Rated Load	Boom Angle	*Rated Load	**Rated Load	Boom Angle	*Rated Load	**Rated Load	Front Rating	360° Rating	
6' (1.8 m)	57°	30,000 lb (13,608 kg)	30,000 lb (13,608 kg)	71°	25,700 lb (11,658 kg)	25,700 lb (11,658 kg)	77°	23,100 lb (10,478 kg)	23,100 lb (10,478 kg)	80°	18,600 lb (8437 kg)	18,600 lb (8437 kg)	16,000 lb (7258 kg)	10,900 lb (4944 kg)	
8' (2.4 m)	47°	27,200 lb (12,338 kg)	27,200 lb (12,338 kg)	66°	25,500 lb (11,567 kg)	25,500 lb (11,567 kg)	73°	22,400 lb (10,161 kg)	22,400 lb (10,161 kg)	77°	17,500 lb (7938 kg)	17,500 lb (7938 kg)	13,000 lb (5897 kg)	8,700 lb (3946 kg)	
10' (3.0 m)	33°	24,000 lb (10,886 kg)	20,000 lb (9072 kg)	61°	23,600 lb (10,705 kg)	20,000 lb (9072 kg)	69°	21,700 lb (9843 kg)	20,000 lb (9072 kg)	74°	16,500 lb (7484 kg)	16,500 lb (7484 kg)	11,000 lb (4990 kg)	7,400 lb (3357 kg)	
11.50' (3.5 m)	0°	20,100 lb (9117 kg)	15,000 lb (6804 kg)	56°	20,200 lb (9163 kg)	15,400 lb (6985 kg)	67°	19,700 lb (8936 kg)	15,400 lb (6985 kg)	72°	15,800 lb (7167 kg)	15,200 lb (6895 kg)	-	-	
12' (3.7 m)	-	-	-	55°	19,200 lb (8709 kg)	14,200 lb (6441 kg)	66°	19,000 lb (8618 kg)	14,200 lb (6441 kg)	71°	15,600 lb (7076 kg)	14,100 lb (6396 kg)	9,450 lb (4287 kg)	6,400 lb (2903 kg)	
14' (4.3 m)	-	-	-	48°	16,100 lb (7303 kg)	10,900 lb (4944 kg)	62°	15,900 lb (7212 kg)	10,800 lb (4899 kg)	68°	14,800 lb (6713 kg)	10,900 lb (4944 kg)	8,200 lb (3720 kg)	5,600 lb (2540 kg)	
16' (4.9 m)	-	-	-	41°	13,700 lb (6214 kg)	8,600 lb (3901 kg)	58°	13,600 lb (6169 kg)	8,700 lb (3946 kg)	66°	13,300 lb (6033 kg)	8,500 lb (3856 kg)	7,000 lb (3175 kg)	4,900 lb (2223 kg)	
18' (5.5 m)	-	-	-	33°	11,900 lb (5398 kg)	7,100 lb (3221 kg)	54°	11,800 lb (5353 kg)	7,100 lb (3221 kg)	63°	11,700 lb (5321 kg)	7,100 lb (3221 kg)	6,000 lb (2722 kg)	4,300 lb (1951 kg)	
20' (6.1 m)	-	-	-	21°	10,400 lb (4717 kg)	5,900 lb (2676 kg)	49°	10,350 lb (4695 kg)	6,000 lb (2722 kg)	60°	10,300 lb (4672 kg)	5,900 lb (2676 kg)	5,100 lb (2313 kg)	3,750 lb (1701 kg)	
21.00' (6.4 m)	-	-	-	0°	9,700 lb (4400 kg)	5,400 lb (2449 kg)	47°	9,650 lb (4377 kg)	5,600 lb (2540 kg)	58°	9,600 lb (4355 kg)	5,500 lb (2495 kg)	-	-	
22' (6.7 m)	-	-	-	-	-	-	44°	9,200 lb (4173 kg)	5,100 lb (2313 kg)	56°	9,100 lb (4128 kg)	5,000 lb (2268 kg)	4,400 lb (1996 kg)	3,300 lb (1497 kg)	
24' (7.3 m)	-	-	-	-	-	-	39°	8,300 lb (3765 kg)	4,400 lb (1996 kg)	53°	8,100 lb (3674 kg)	4,300 lb (1951 kg)	3,800 lb (1724 kg)	2,800 lb (1270 kg)	
26' (7.9 m)	-	-	-	-	-	-	33°	7,300 lb (3311 kg)	3,600 lb (1633 kg)	50°	7,200 lb (3266 kg)	3,700 lb (1678 kg)	3,350 lb (1520 kg)	2,450 lb (1111 kg)	
28' (8.5 m)	-	-	-	-	-	-	25°	6,500 lb (2948 kg)	3,200 lb (1452 kg)	46°	6,400 lb (2903 kg)	3,200 lb (1452 kg)	2,950 lb (1338 kg)	2,200 lb (998 kg)	
30' (9.1 m)	-	-	-	-	-	-	13°	6,100 lb (2767 kg)	2,800 lb (1270 kg)	42°	5,700 lb (2586 kg)	2,800 lb (1270 kg)	2,600 lb (1179 kg)	1,950 lb (885 kg)	
30.50' (9.3 m)	-	-	-	-	-	-	0°	6,000 lb (2722 kg)	2,700 lb (1225 kg)	41°	5,600 lb (2540 kg)	2,700 lb (1225 kg)	-	-	
32' (9.8 m)	-	-	-	-	-	-	-	-	-	38°	5,200 lb (2359 kg)	2,500 lb (1134 kg)	2,350 lb (1066 kg)	1,700 lb (771 kg)	
34' (10.4 m)	-	-	-	-	-	-	-	-	-	33°	4,700 lb (2132 kg)	2,200 lb (998 kg)	2,100 lb (953 kg)	1,500 lb (680 kg)	
36' (11.0 m)	-	-	-	-	-	-	-	-	-	27°	4,300 lb (1951 kg)	2,000 lb (907 kg)	1,950 lb (885 kg)	1,350 lb (612 kg)	
38' (11.6 m)	-	-	-	-	-	-	-	-	-	20°	4,000 lb (1814 kg)	1,800 lb (817 kg)	1,700 lb (771 kg)	1,200 lb (544 kg)	
40' (12.2 m)	Shaded areas are governed by structural strength. Do not rely on tipping.										0°	3,700 lb (1678 kg)	1,700 lb (771 kg)	1,550 lb (703 kg)	1,050 lb (476 kg)

For 360° rating on rubber, rear axle locks must be in place.

15' (4.6 m) Jib Capacities on Outriggers							
Main Boom Angle	Jib Offset Angle			Main Boom Angle	Jib Offset Angle		
	0°	15°	30°		0°	15°	30°
80°	-	5,000 lb (2268 kg)	3,500 lb (1588 kg)	35°	2,600 lb (1179 kg)	2,150 lb (975 kg)	1,900 lb (862 kg)
75°	*7,500 lb (3402 kg)	4,400 lb (1996 kg)	3,100 lb (1406 kg)	30°	2,400 lb (1089 kg)	2,080 lb (944 kg)	1,850 lb (839 kg)
70°	*6,100 lb (2767 kg)	3,900 lb (1769 kg)	2,800 lb (1270 kg)	25°	2,300 lb (1043 kg)	2,050 lb (930 kg)	-
65°	5,000 lb (2268 kg)	3,500 lb (1588 kg)	2,550 lb (1157 kg)	20°	2,200 lb (998 kg)	2,000 lb (907 kg)	-
60°	4,300 lb (1951 kg)	3,150 lb (1429 kg)	2,350 lb (1066 kg)	15°	2,100 lb (953 kg)	1,950 lb (885 kg)	-
55°	3,800 lb (1724 kg)	2,850 lb (1293 kg)	2,200 lb (998 kg)	10°	2,050 lb (930 kg)	-	-
50°	3,400 lb (1542 kg)	2,600 lb (1179 kg)	2,100 lb (953 kg)	5°	2,020 lb (916 kg)	-	-
45°	3,050 lb (1384 kg)	2,400 lb (1089 kg)	2,000 lb (907 kg)	0°	2,000 lb (907 kg)	-	-
40°	2,800 lb (1270 kg)	2,250 lb (1021 kg)	1,950 lb (885 kg)				

Shaded areas are governed by structural strength. Do not rely on tipping. Jib loads must not exceed main boom capacity. *Do not exceed 34' (10.4 m) main boom length.

Rating reduction for load handling devices installed.
Main block 210 lbs. (95.3 kg), hook & ball 94 lbs. (42.6 kg)

SPECIFICATIONS 5500 Series continued

ACCESSORIES & ATTACHMENTS

- Cold start kit
- LMI indicator system
- Flashing strobe light
- Rear hitch (pintle)
- Front hitch (pintle)
- Jib-15' (4.6 m) off-settable
- Hydraulic recessed winch
- Heater and defroster (hot water)
- Spare wheel and tire
- Engine shut down gauges
- 2 man work platform
- Dual rearview mirrors
- Sliding right window
- Foam filled tires
- Anti-skid pads on deck
- Fire extinguisher
- Lift lugs (four)
- Hook and ball, for single part line
- Catalytic convertor for diesel

HYDRAULIC SYSTEM

Main pump: Gear-type with three sections

Section 1.....	40 gpm (151.4 l/min)
Section 2.....	23 gpm (87.1 l/min)
Section 3.....	16 gpm (60.6 l/min)

Swing system: 360° hydraulic swing system has positive operator control.
Swing speed: continuous at 2.5 rpm.
System pressure: 3500 psi (24,133 kPa)

CYLINDERS

CYCLE TIME

800 rpm 2500 rpm

Hoist cylinder (full stroke):		
Extend	60.0 sec.....	18.0 sec
Retract.....	44.0 sec.....	13.0 sec
Crowd cylinder (full stroke):		
Extend.....	120.0 sec	32.0 sec
Retract.....	65.7 sec.....	49.8 sec
Outriggers (individual):		
Out	16.0 sec.....	1.8 sec
Down	42.0 sec.....	5.6 sec
Up	47.0 sec.....	4.5 sec
In.....	17.0 sec.....	1.2 sec

DRAWBAR PULL

Unit equipped with 385/65R22.5 tires, diesel engine and no load on deck.

TWO-WHEEL DRIVE

1st gear.....	15,150 lb (6872 kg)
2nd gear.....	8,750 lb (3969 kg)
3rd gear	4,788 lb (2172 kg)
4th gear.....	2,763 lb (1253 kg)

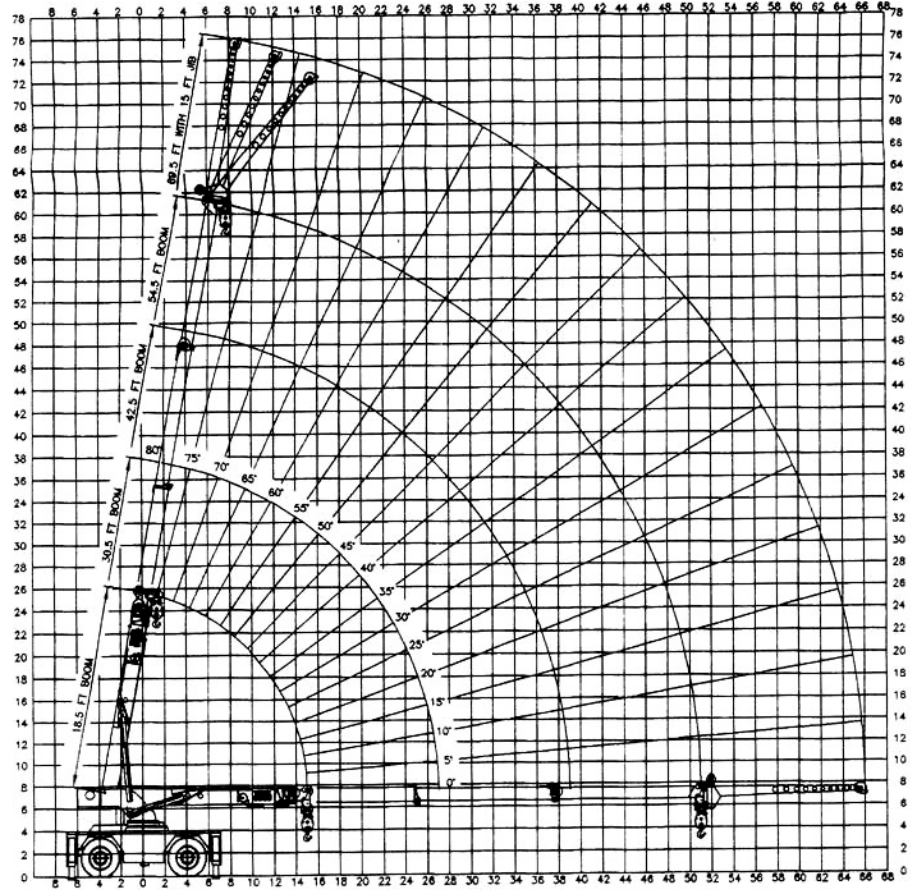

5560 4-SECTION BOOM WITH 15' (4.6M) JIB

15 ton (13.6 metric ton) main block, 210 lb (95.3 kg), and 5 ton (4.5 metric ton) ball and hook, 94 lb (42.6 kg)

FOUR-WHEEL DRIVE

1st gear.....	19,950 lb (9049 kg)
2nd gear.....	11,113 lb (5041 kg)
3rd gear	6,000 lb (2722 kg)
4th gear	3,500 lb (1588 kg)

ENGINE

5540 - Standard for 2-wheel drive

Make and model.....	Cummins 4B3.9 diesel
Number of cylinders.....	4
Horsepower	76 @ 2500 rpm

Optional Engine for 4-wheel drive

(5540 only)	
Make and model.....	Cummins 4BT3.9 diesel
Horsepower	110 @ 2500 rpm

5550RT & 5560RT - Standard

Make and model.....	Cummins 4BT3.9 diesel
Number of cylinders.....	4
Horsepower	110 @ 2500 rpm

Optional Engine

Make and model.....	GM 4.3L V-6
Fuel.....	Gas or dual fuel (Gas/LP)
Horsepower	
Gas	110 @ 2500 rpm
LP.....	101 @ 2500 rpm

ELECTRICAL

Starting	12 volt electric
Battery (1)	530 CCA @ 0° F (-18°C)
	for 30 sec. rate (2 batteries with cold-start option)
Alternator	63 amp

TRANSMISSION

Type	powershift transmission with 4-speed forward/4-speed reverse with electric powershift on column
------------	---

Unit standard with transmission oil cooler and filter.

RATED LOAD CAPACITIES 5560RT

Operating Radius	*On Extended and Down Outriggers Less Jib 360° or Retracted and Down Front /Rear **On Retracted and Down Outriggers Less Jib 360°												On Rubber Less Jib 360° <small>For 360° rating on rubber, rear axle locks must be in place.</small>	
	18.5' (5.6 m) Boom			30.5' (9.3 m) Boom			42.5' (13.0 m) Boom			54.5' (16.6 m) Boom			Any Boom Length	
	Boom Angle	*Rated Load	**Rated Load	Boom Angle	*Rated Load	**Rated Load	Boom Angle	*Rated Load	**Rated Load	Boom Angle	*Rated Load	**Rated Load	Front Rating	360° Rating
6' (1.8 m)	64°	30,000 lb (13,608 kg)	30,000 lb (13,608 kg)	75°	26,000 lb (11,794 kg)	26,000 lb (11,794 kg)	79°	24,000 lb (10,886 kg)	24,000 lb (10,886 kg)	-	-	-	16,000 lb (7258 kg)	10,900 lb (4944 kg)
8' (2.4 m)	57°	27,200 lb (12,338 kg)	27,200 lb (12,338 kg)	71°	25,000 lb (11,340 kg)	25,000 lb (11,340 kg)	77°	23,000 lb (10,433 kg)	23,000 lb (10,433 kg)	80°	19,000 lb (8618 kg)	19,000 lb (8618 kg)	13,000 lb (5897 kg)	8,700 lb (3946 kg)
10' (3.0 m)	49°	24,000 lb (10,886 kg)	16,000 lb (7258 kg)	67°	24,000 lb (10,886 kg)	22,000 lb (9979 kg)	74°	21,500 lb (9752 kg)	20,000 lb (9072 kg)	77°	18,000 lb (8165 kg)	18,000 lb (8165 kg)	11,000 lb (4990 kg)	7,400 lb (3357 kg)
12' (3.7 m)	39°	19,500 lb (8845 kg)	11,400 lb (5171 kg)	63°	20,000 lb (9072 kg)	12,900 lb (5851 kg)	71°	19,700 lb (8936 kg)	12,800 lb (5806 kg)	75°	17,100 lb (7757 kg)	13,000 lb (5897 kg)	9,100 lb (4128 kg)	6,400 lb (2903 kg)
14' (4.3 m)	25°	16,200 lb (7348 kg)	8,900 lb (4037 kg)	58°	16,800 lb (7621 kg)	9,900 lb (4491 kg)	68°	17,000 lb (7711 kg)	10,200 lb (4627 kg)	73°	16,300 lb (7394 kg)	10,600 lb (4808 kg)	7,800 lb (3538 kg)	5,600 lb (2540 kg)
15.0' (4.6 m)	0°	15,000 lb (4572 kg)	8,000 lb (3629 kg)	56°	15,500 lb (7031 kg)	8,900 lb (4037 kg)	66°	15,800 lb (7167 kg)	9,300 lb (4219 kg)	72°	15,800 lb (7167 kg)	9,500 lb (4309 kg)	-	-
16' (4.9 m)	-	-	-	53°	14,400 lb (6532 kg)	8,100 lb (3674 kg)	65°	14,600 lb (6623 kg)	8,500 lb (3856 kg)	71°	14,800 lb (6713 kg)	8,500 lb (3856 kg)	6,500 lb (2948 kg)	4,900 lb (2232 kg)
18' (5.5 m)	-	-	-	48°	12,500 lb (5670 kg)	6,800 lb (3085 kg)	62°	12,700 lb (5761 kg)	7,200 lb (3266 kg)	69°	13,000 lb (5897 kg)	7,200 lb (3266 kg)	5,600 lb (2540 kg)	4,200 lb (1905 kg)
20' (6.1 m)	-	-	-	43°	11,000 lb (4990 kg)	5,900 lb (2676 kg)	59°	11,200 lb (5080 kg)	6,200 lb (2812 kg)	66°	11,400 lb (5171 kg)	6,100 lb (2767 kg)	4,800 lb (2177 kg)	3,500 lb (1587 kg)
22' (6.7 m)	-	-	-	37°	9,800 lb (4445 kg)	5,000 lb (2268 kg)	55°	10,000 lb (4536 kg)	5,200 lb (2359 kg)	64°	10,100 lb (4581 kg)	5,300 lb (2404 kg)	4,200 lb (1905 kg)	3,000 lb (1361 kg)
24' (7.3 m)	-	-	-	29°	8,700 lb (3946 kg)	4,100 lb (1860 kg)	52°	9,000 lb (4082 kg)	4,500 lb (2041 kg)	61°	9,000 lb (4082 kg)	4,500 lb (2041 kg)	3,600 lb (1633 kg)	2,500 lb (1134 kg)
26' (7.9 m)	-	-	-	18°	7,800 lb (3538 kg)	3,600 lb (1633 kg)	48°	8,100 lb (3674 kg)	3,800 lb (1724 kg)	59°	8,100 lb (3674 kg)	3,900 lb (1769 kg)	3,150 lb (1429 kg)	2,200 lb (998 kg)
27.0' (8.2 m)	-	-	-	0°	7,400 lb (3357 kg)	3,400 lb (1542 kg)	46°	7,700 lb (3493 kg)	3,600 lb (1633 kg)	58°	7,800 lb (3538 kg)	3,600 lb (1633 kg)	-	-
28' (8.5 m)	-	-	-	-	-	-	44°	7,300 lb (3311 kg)	3,300 lb (1497 kg)	56°	7,400 lb (3357 kg)	3,300 lb (1497 kg)	2,800 lb (1270 kg)	1,900 lb (862 kg)
30' (9.1 m)	-	-	-	-	-	-	40°	6,500 lb (2948 kg)	2,900 lb (1315 kg)	54°	6,700 lb (3039 kg)	2,800 lb (1270 kg)	2,450 lb (1111 kg)	1,650 lb (748 kg)
32' (9.8 m)	-	-	-	-	-	-	36°	5,700 lb (2586 kg)	2,500 lb (1134 kg)	51°	6,000 lb (2722 kg)	2,500 lb (1134 kg)	2,100 lb (953 kg)	1,400 lb (635 kg)
34' (10.4 m)	-	-	-	-	-	-	30°	5,100 lb (2313 kg)	2,200 lb (998 kg)	48°	5,400 lb (2449 kg)	2,200 lb (998 kg)	1,900 lb (862 kg)	1,200 lb (544 kg)
36' (11.0 m)	-	-	-	-	-	-	24°	4,500 lb (2041 kg)	2,000 lb (907 kg)	45°	4,800 lb (2177 kg)	2,000 lb (907 kg)	1,750 lb (794 kg)	1,000 lb (454 kg)
38' (11.6 m)	-	-	-	-	-	-	15°	4,000 lb (1814 kg)	1,800 lb (817 kg)	42°	4,300 lb (1951 kg)	1,800 lb (817 kg)	1,525 lb (692 kg)	850 lb (386 kg)
39.0' (11.9 m)	-	-	-	-	-	-	0°	3,900 lb (1769 kg)	1,700 lb (771 kg)	41°	4,000 lb (1814 kg)	1,700 lb (771 kg)	-	-
40' (12.2 m)	-	-	-	-	-	-	-	-	-	39°	3,800 lb (1724 kg)	1,600 lb (726 kg)	1,350 lb (612 kg)	725 lb (329 kg)
42' (12.8 m)	-	-	-	-	-	-	-	-	-	35°	3,400 lb (1542 kg)	1,400 lb (635 kg)	1,150 lb (522 kg)	625 lb (284 kg)
44' (13.4 m)	-	-	-	-	-	-	-	-	-	31°	3,100 lb (1406 kg)	1,300 lb (590 kg)	1,050 lb (476 kg)	525 lb (238 kg)
46' (14.0 m)	-	-	-	-	-	-	-	-	-	27°	2,900 lb (1315 kg)	1,100 lb (499 kg)	950 lb (431 kg)	425 lb (193 kg)
48' (14.6 m)	-	-	-	-	-	-	-	-	-	21°	2,700 lb (1225 kg)	900 lb (408 kg)	850 lb (386 kg)	300 lb (136 kg)
51.0'	-	-	-	-	-	-	-	-	-	0°	2,400 lb (1089 kg)	700 lb (318 kg)	700 lb (318 kg)	200 lb (91 kg)

Shaded areas are governed by structural strength. Do not rely on tipping.

15' (4.6 m) Jib Capacities on Outriggers

Main Boom Angle	Jib Offset Angle					Main Boom Angle	Jib Offset Angle					Main Boom Angle	Jib Offset Angle				
	0°		15°		30°		0°		15°		30°		0°		15°		30°
	To 42.5 ft Main Boom	To 54.5 ft Main Boom	To 42.5 ft Main Boom	To 54.5 ft Main Boom	Any Boom Length		To 42.5 ft Main Boom	To 54.5 ft Main Boom	To 42.5 ft Main Boom	To 54.5 ft Main Boom	Any Boom Length		To 42.5 ft Main Boom	To 54.5 ft Main Boom	To 42.5 ft Main Boom	To 54.5 ft Main Boom	Any Boom Length
80°	-	-	5,000 lb (2268 kg)	5,000 lb (2268 kg)	3,500 lb (1588 kg)	50°	3,400 lb (1542 kg)	3,400 lb (1542 kg)	2,600 lb (1179 kg)	2,600 lb (1179 kg)	2,100 lb (953 kg)	20°	2,200 lb (998 kg)	1,600 lb (726 kg)	2,000 lb (907 kg)	1,590 lb (721 kg)	-
75°	7,500 lb (3402 kg)	-	4,400 lb (1996 kg)	4,400 lb (1996 kg)	3,100 lb (1406 kg)	45°	3,050 lb (1384 kg)	2,900 lb (1315 kg)	2,400 lb (1089 kg)	2,400 lb (1089 kg)	2,000 lb (907 kg)	15°	2,100 lb (953 kg)	1,500 lb (680 kg)	1,950 lb (885 kg)	1,520 lb (690 kg)	-
70°	6,100 lb (2767 kg)	-	3,900 lb (1769 kg)	3,900 lb (1769 kg)	2,800 lb (1270 kg)	40°	2,800 lb (1270 kg)	2,450 lb (1111 kg)	2,250 lb (1021 kg)	2,250 lb (1021 kg)	1,950 lb (885 kg)	10°	2,050 lb (930 kg)	1,460 lb (662 kg)	-	-	-
65°	5,000 lb (2268 kg)	5,000 lb (2268 kg)	3,500 lb (1588 kg)	3,500 lb (1588 kg)	2,550 lb (1157 kg)	35°	2,600 lb (1179 kg)	2,150 lb (975 kg)	2,150 lb (975 kg)	2,050 lb (930 kg)	1,900 lb (862 kg)	5°	2,020 lb (916 kg)	1,450 lb (658 kg)	-	-	-
60°	4,300 lb (1951 kg)	4,300 lb (1951 kg)	3,150 lb (1429 kg)	3,150 lb (1429 kg)	2,350 lb (1066 kg)	30°	2,400 lb (1089 kg)	1,930 lb (876 kg)	2,080 lb (944 kg)	1,850 lb (839 kg)	1,830 lb (830 kg)	0°	2,000 lb (907 kg)	1,440 lb (653 kg)	-	-	-
55°	3,800 lb (1724 kg)	3,800 lb (1724 kg)	2,850 lb (1293 kg)	2,850 lb (1293 kg)	2,200 lb (998 kg)	25°	2,300 lb (1043 kg)	1,750 lb (794 kg)	2,050 lb (930 kg)	1,720 lb (780 kg)	-	-	-	-	-	-	-

OPERATING DATA *5500 Series continued*

DRIVE AXLE - Front

Rigid mounted planetary drive/steer with limited slip.

DRIVE AXLE - Rear

Planetary drive/steer axle with 4° of oscillation.

TIRE SIZE

385/65R22.5 radial, high traction tread

TURNING SPECIFICATIONS

Turning radius: to \odot of outside wheels
2-wheel steer 21'6" (6.55 m)
4-wheel steer 12'4" (3.76 m)

TRAVEL SPEEDS

Standard tires, diesel engine
1st gear 4 mph (6.4 k/h)
2nd gear 7 mph (11.3 k/h)
3rd gear 13 mph (20.9 k/h)
4th gear:
2-wheel drive ... 19 mph (30.6 k/h)
4-wheel drive ... 21 mph (33.8 k/h)

MAXIMUM GRADEABILITY (PAVED SURFACE)

1st gear and torque converted
(calculated), standard tires:
No load 68%
20,000 lb (9072 kg) load 40%

NOTE: Gradeability is a measure of tractive effort only and does not represent grades on which the machine can operate.

NOTE: All specifications are stated in accordance with PCSA definitions, SAE standards or recommended practices, where applicable.

IMPORTANT: Shuttlelift reserves the right to change these specifications without notice and without incurring any obligation relating to such changes.



Leading the Way in Material Handling

SHUTTLELIFT, INC., 49 E. Yew St., P.O. Box 66, Sturgeon Bay, WI 54235-0066 USA
Phone: 920-743-8650 ■ Fax: 920-743-1522

■ E-mail: lifts@shuttlelift.com ■ Web-site: www.shuttlelift.com