



Grue Tout-Terrain Capacité 200 Tonnes
All-Terrain Crane Capacity 200 Tons



Demag AC180

Key



counterweight



Lifting capacities on outriggers 360°

„D“

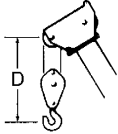

Contents

Specifications

Dimensions	4
Specifications	8

Main boom

Working ranges	9
Lifting capacities	10

Main boom extension

Working ranges, main boom 181.1 ft	18
Lifting capacities (181.1 ft + 31.8 ft/47.5 ft/67.2 ft)	19
Working ranges, main boom 197.0 ft	20
Lifting capacities (197.0 ft + 31.8 ft/47.5 ft/67.2 ft)	21
Working ranges, main boom 181.1 ft	22
Lifting capacities (181.1 ft + 86.9 ft/106.6 ft/126.3 ft)	23
Working ranges, main boom 197.0 ft	24
Lifting capacities (197.0 ft + 86.9 ft/106.6 ft)	25

Luffing fly jib

Lifting capacities, main boom (48.2 ft)	26
Lifting capacities, main boom (81.7 ft)	27
Lifting capacities, main boom (114.8 ft)	29
Working ranges, main boom 82° to 65° (48.2 ft/81.7 ft/114.8 ft)	30
Working ranges, main boom 82° to 65° (131.6 ft/148.0 ft/164.7 ft/181.1 ft)	31
Lifting capacities, main boom (131.6 ft + 148.0 ft)	32
Lifting capacities, main boom (164.7 ft + 181.1 ft)	33

Technical description

Carrier · Superstructure · Optional equipment	34
---	----

Dimensions of 6-axle-carrier

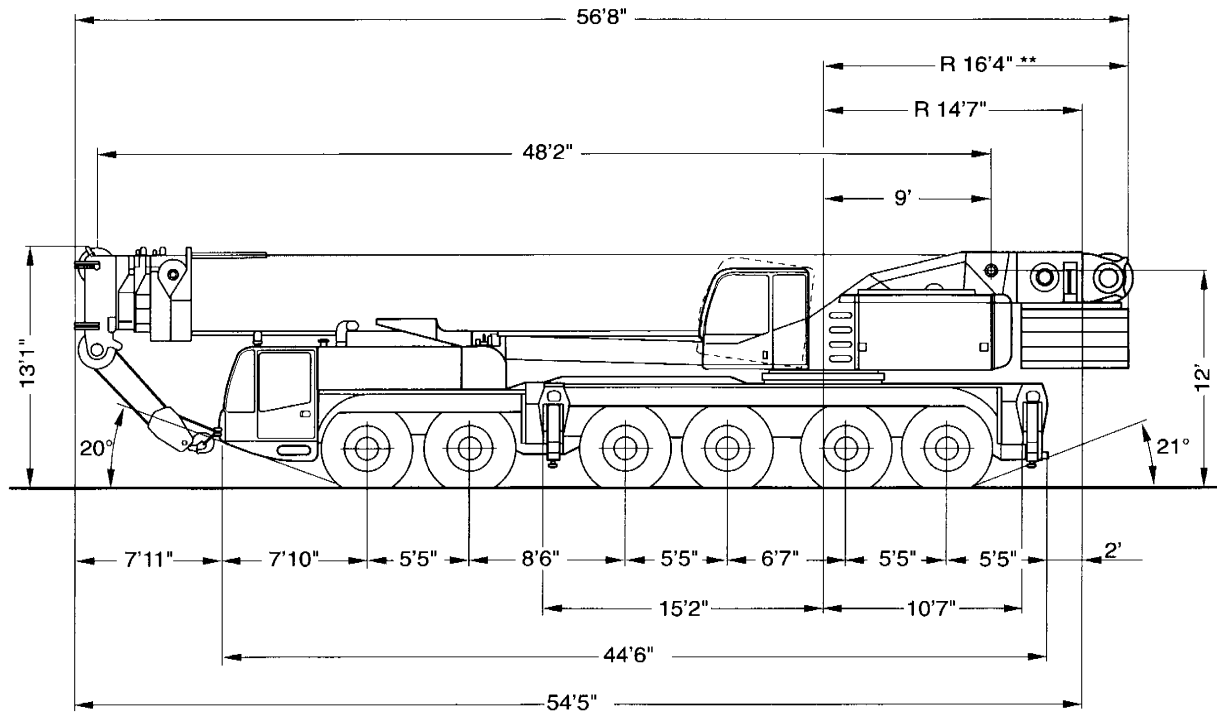

**up to 88,000 lb

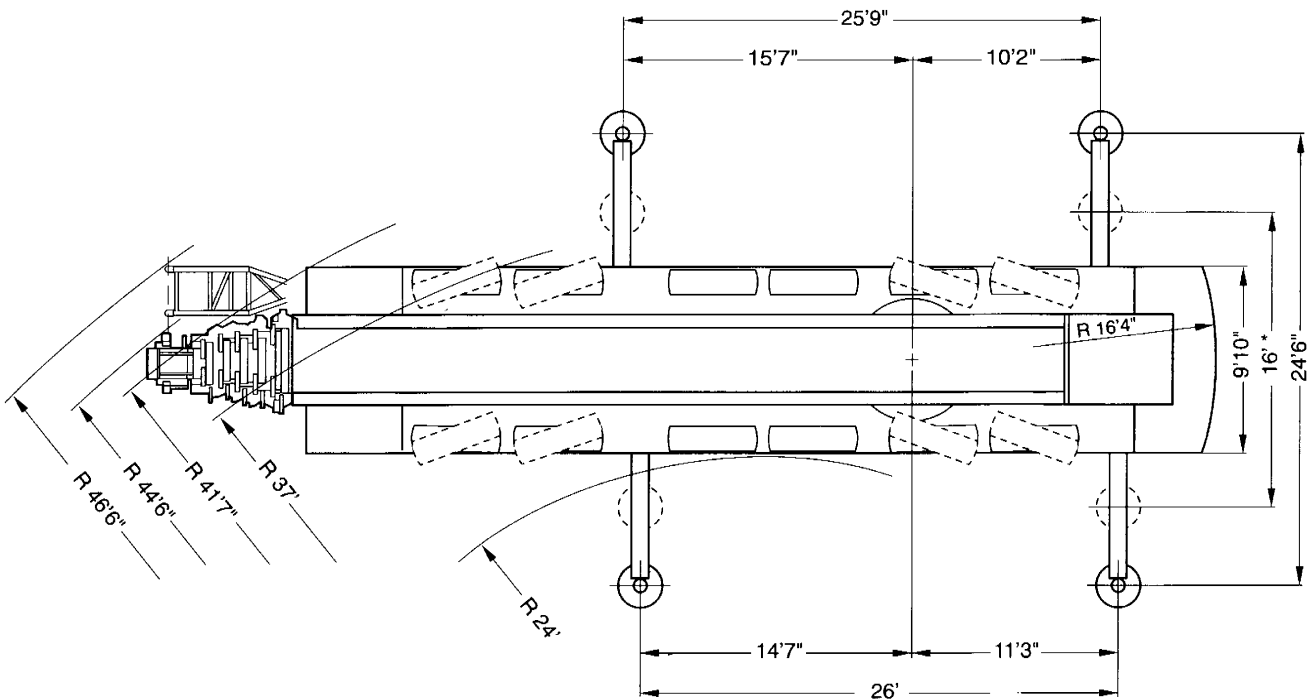

* Duties with reduced outrigger base on request

Dimensions of 6-axle-carrier

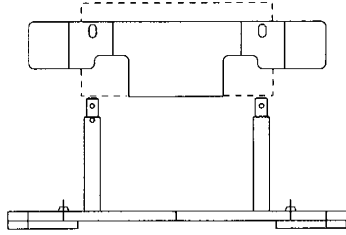

13,500 lb (9,200 lb carrier + 4,300 lb superstructure)
counterweight + hoist II
or equivalent weight for hoist II

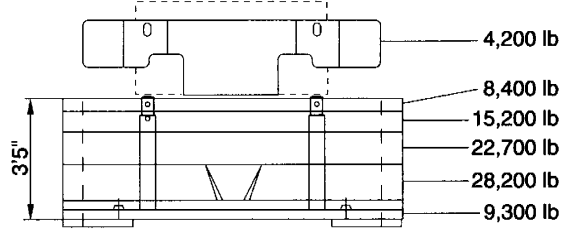

88,000 lb counterweight

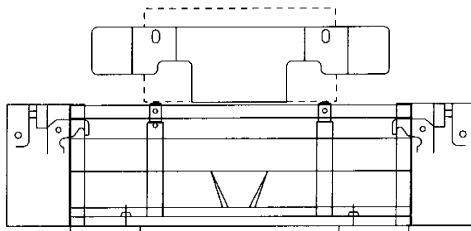
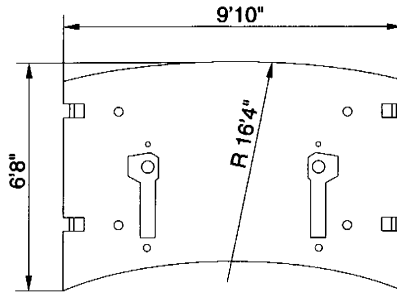

119,000 lb counterweight (optional)

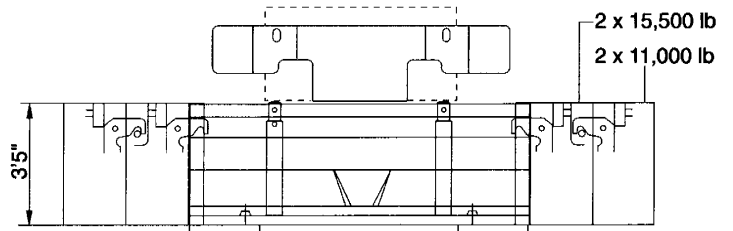

141,000 lb counterweight (optional)

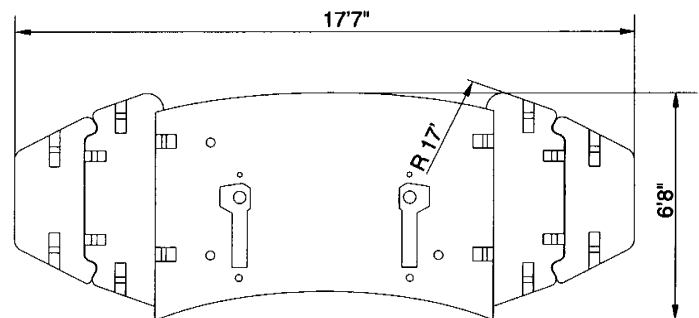
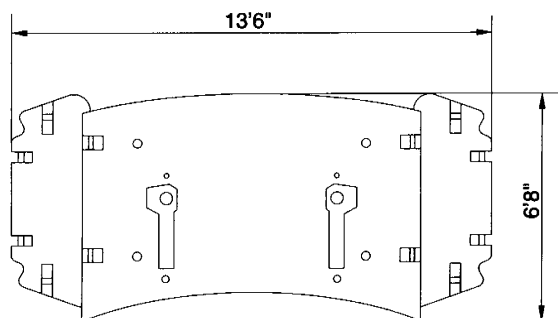

Dimensions of 5-axle carrier (option)

Weight in travel order: 132,300 lb

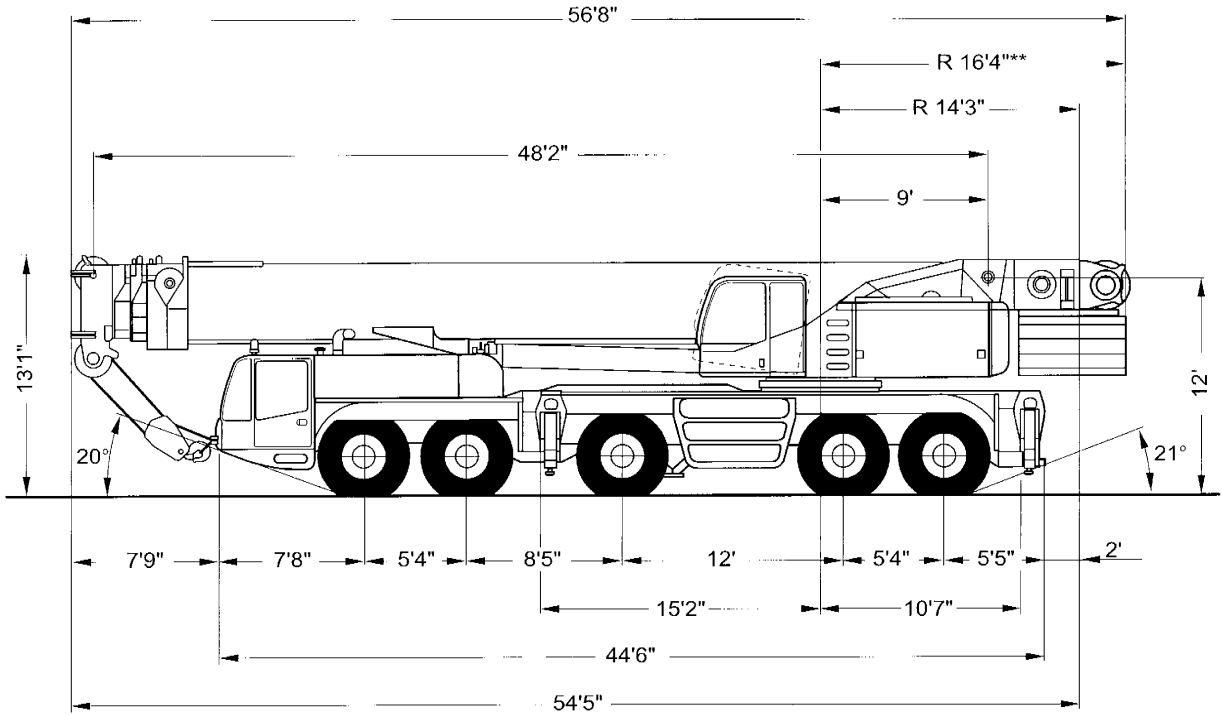

** up to 88,000 lb

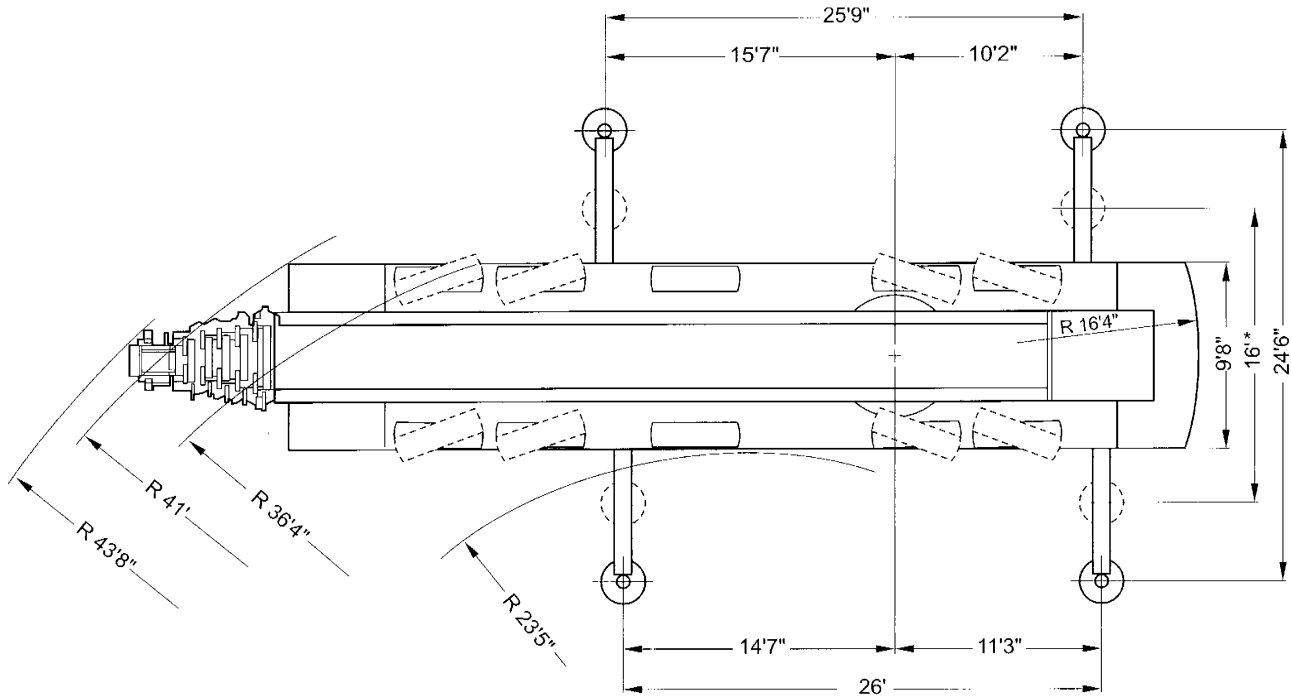

* Duties with reduced outrigger base on request

Dimensions of 5-axle carrier (option)

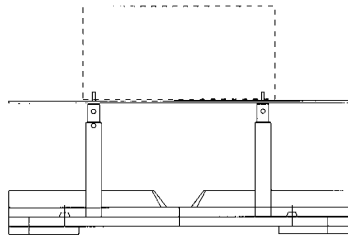

27,500 lb counterweight + hoist II
or equivalent weight for hoist II

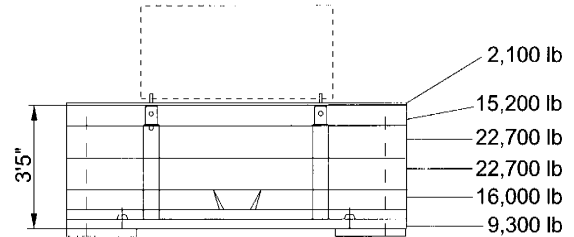

88,000 lb counterweight

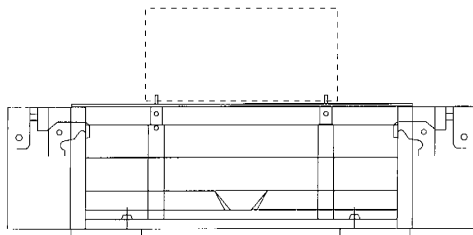
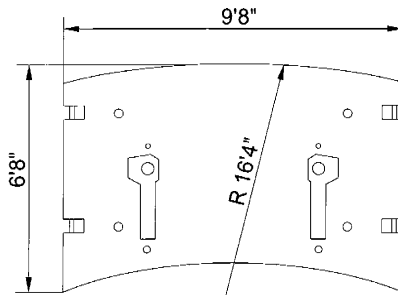

119,000 lb counterweight (optional)

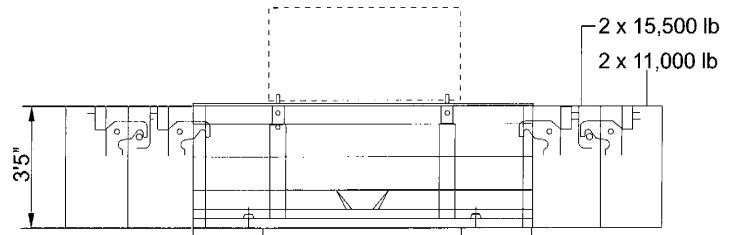

141,000 lb counterweight (optional)

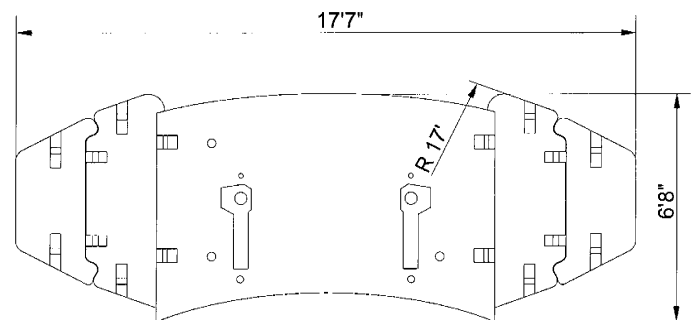
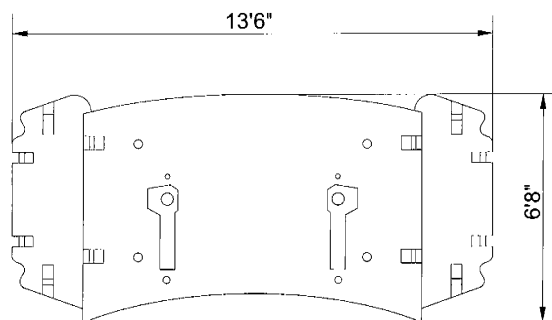

Specifications

Working speeds (infinitely variable)

Mechanisms	Normal speed	High speed	Max. permissible line pull ¹⁾	Rope Ø / Rope length
Hoist I	131 ft/min	400 ft/min	21,000 lb	23 mm / 984 ft
Hoist II	131 ft/min	400 ft/min	21,000 lb	23 mm / 984 ft
Slewing				max. 1.5 1/min
Telescoping speed				48.2 – 81.7 ft: 40 s 48.2 – 114.8 ft: 85 s 48.2 – 197.0 ft: 250 s
Boom elevation				-1.3° – +82.5°: 85 s

Carrier performance

Travel speed	0..45/49 mph ²⁾
Gradeability	65%
Ground clearance	1'4" / 1'6" ²⁾

Hook block/Single line hook

Type	Possible load ¹⁾	Number of sheaves	Weight	„D“	Max. reeving	Heavy-lift attachment
200	396,800 lb	11	4.400 lb	10 ft	22	5 add. sheaves
200	357,200 lb	9	4.200 lb	10 ft	19	5 add. sheaves
160	286,600 lb	7	3.300 lb	10 ft	15	2 add. sheaves
125	213,800 lb	5	2.600 lb	10 ft	11	-
80	138,900 lb	3	2.300 lb	10 ft	7	-
40	61,700 lb	1	1.700 lb	9 ft	3	-
12,5	20,500 lb	Single line hook	1.100 lb	7 ft	1	-

Remarks

¹⁾ varies depending on national regulations

²⁾ depending on type of tires (14.00/16.00)

Working ranges main boom

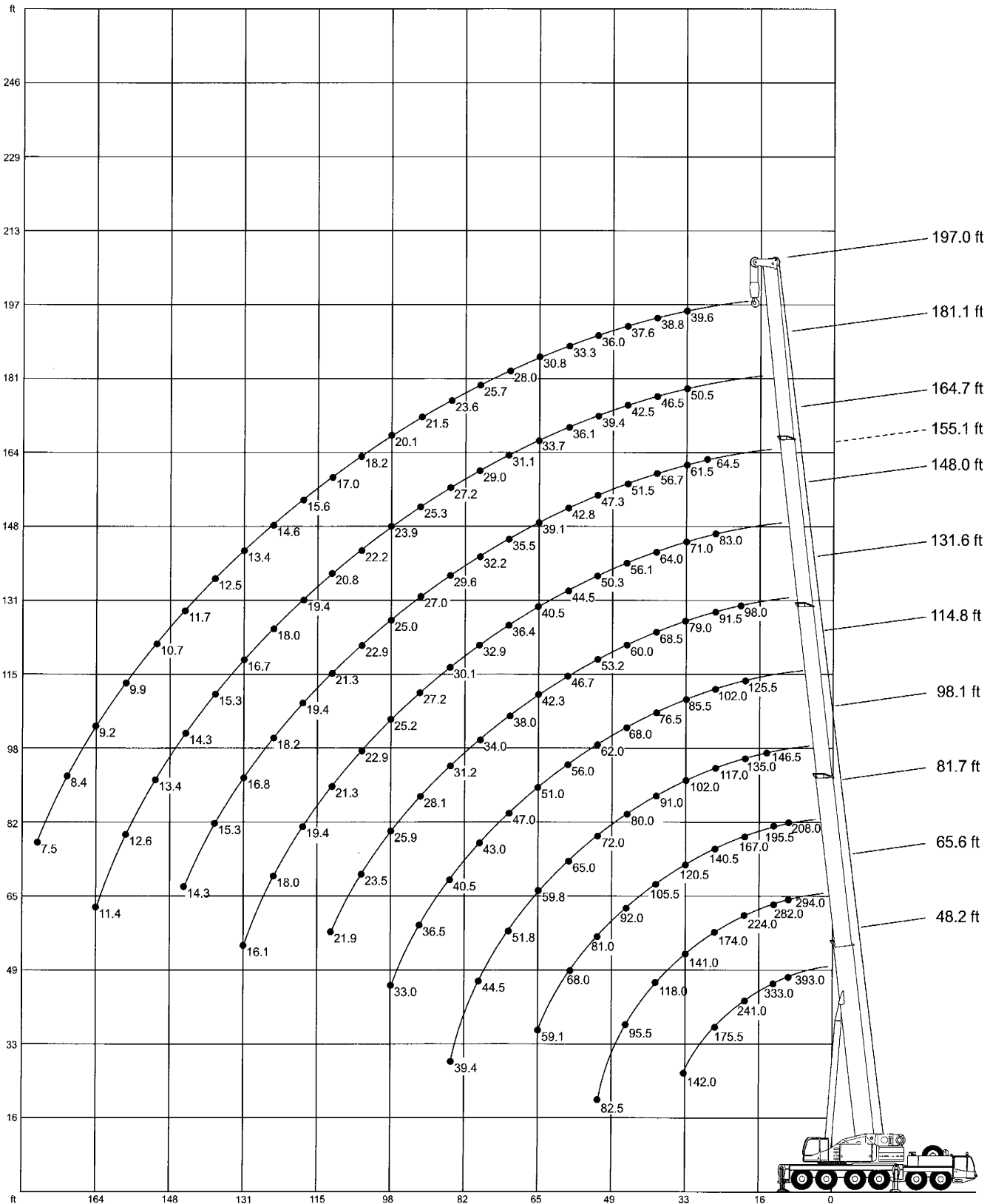

Lifting capacities main boom

141,000 lb



360°

85%

Radius ft	Main boom											
	48.2 ft**	48.2 ft	65.6 ft	81.7 ft	98.1 ft	114.8 ft	114.8 ft	131.6 ft	148.0 ft	164.7 ft	181.1 ft	197.0 ft
	1,000 lb											
10	400.0 ¹⁾	338.0	294.0	208.0	-	-	-	-	-	-	-	-
11	375.0 ¹⁾	321.0	290.0	203.0	-	-	-	-	-	-	-	-
13	333.0 ¹⁾	290.0	282.0	195.5	-	-	-	-	-	-	-	-
15	300.0 ¹⁾	264.0	263.0	185.0	146.5	-	-	-	-	-	-	-
16	285.0 ¹⁾	253.0	251.0	180.0	143.5	-	-	-	-	-	-	-
19	241.0	224.0	224.0	167.0	135.0	125.5	109.0	-	-	-	-	-
23	198.0	193.5	192.0	150.5	124.0	111.0	101.0	98.0	-	-	-	-
26	175.5	175.5	174.0	140.5	117.0	102.0	96.0	91.5	83.0	-	-	-
29	159.0	159.0	159.0	131.5	110.0	94.5	91.0	85.5	78.0	64.5	-	-
33	142.0	142.0	141.0	120.5	102.0	85.5	85.5	79.0	71.0	61.5	50.5	39.6
39	-	-	118.0	105.5	91.0	74.5	76.5	68.5	64.0	56.7	46.5	38.8
46	-	-	95.5	92.0	80.0	63.5	68.0	60.0	56.1	51.5	42.5	37.6
52	-	-	82.5	81.0	72.0	56.5	62.0	53.2	50.3	47.3	39.4	36.0
59	-	-	-	68.0	65.0	49.6	56.0	46.7	44.5	42.8	36.1	33.3
65	-	-	-	59.1	59.8	44.6	51.4	42.3	40.5	39.1	33.7	30.8
72	-	-	-	-	51.8	39.8	47.0	38.0	36.4	35.5	31.1	28.0
79	-	-	-	-	44.5	35.8	43.3	34.0	32.9	32.2	29.0	25.7
85	-	-	-	-	39.4	32.7	40.6	31.2	30.1	29.6	27.2	23.6
92	-	-	-	-	-	29.7	36.7	28.1	27.2	27.0	25.3	21.5
98	-	-	-	-	-	27.7	33.1	25.9	25.2	25.0	23.9	20.1
105	-	-	-	-	-	-	-	23.5	22.9	22.9	22.2	18.2
111	-	-	-	-	-	-	-	21.9	21.3	21.3	20.8	17.0
118	-	-	-	-	-	-	-	-	19.4	19.4	19.4	15.6
124	-	-	-	-	-	-	-	-	18.0	18.2	18.0	14.6
131	-	-	-	-	-	-	-	-	16.1	16.8	16.7	13.4
138	-	-	-	-	-	-	-	-	-	15.3	15.3	12.5
144	-	-	-	-	-	-	-	-	-	14.3	14.3	11.7
151	-	-	-	-	-	-	-	-	-	-	13.4	10.7
157	-	-	-	-	-	-	-	-	-	-	12.6	9.9
164	-	-	-	-	-	-	-	-	-	-	11.4	9.2
170	-	-	-	-	-	-	-	-	-	-	-	8.4
177	-	-	-	-	-	-	-	-	-	-	-	7.5

Boom extension sequence in %

Tele 1	0	0	23	45	45	90	45	90	90	90	90	100
Tele 2	0	0	23	45	45	90	45	90	90	90	90	100
Tele 3	0	0	0	0	45	0	45	45	90	90	90	100
Tele 4	0	0	0	0	0	0	45	0	0	45	90	100

Remarks

** special equipment required

1) only 0° over rear

Lifting capacities main boom

119,000 lb



360°

85%

Radius ft	Main boom										
	48.2 ft	65.6 ft	81.7 ft	98.1 ft	114.8 ft	114.8 ft	131.6 ft	148.0 ft	164.7 ft	181.1 ft	197.0 ft
	1,000 lb										
10	334.0	294.0	208.0	-	-	-	-	-	-	-	-
11	317.0	290.0	203.0	-	-	-	-	-	-	-	-
13	286.0	282.0	195.5	-	-	-	-	-	-	-	-
15	259.0	259.0	185.0	146.5	-	-	-	-	-	-	-
16	249.0	249.0	180.0	143.5	-	-	-	-	-	-	-
19	221.0	221.0	167.0	135.0	125.5	109.0	-	-	-	-	-
23	190.0	190.0	150.5	124.0	111.0	101.0	98.0	-	-	-	-
26	172.0	172.0	140.5	117.0	102.0	96.0	91.5	83.0	-	-	-
29	156.5	156.5	131.5	110.0	94.5	91.0	85.5	78.0	64.5	-	-
33	135.5	134.5	120.5	102.0	85.5	85.5	79.0	71.0	61.5	50.5	39.6
39	-	110.5	105.5	91.0	74.5	76.5	68.5	64.0	56.7	46.7	38.8
46	-	89.0	88.0	80.0	63.5	68.0	60.0	56.1	51.5	42.5	37.6
52	-	71.5	71.5	72.0	56.5	62.0	53.2	50.3	47.3	39.4	36.0
59	-	-	58.0	60.5	49.6	56.0	46.7	44.5	42.8	36.1	33.3
65	-	-	49.1	51.6	44.6	51.4	42.3	40.5	39.1	33.7	30.8
72	-	-	-	43.2	39.8	45.7	38.0	36.4	35.5	31.1	28.0
79	-	-	-	36.6	33.7	39.2	34.0	32.9	32.2	29.0	25.7
85	-	-	-	32.1	28.9	34.6	30.8	30.1	29.6	27.2	23.6
92	-	-	-	-	24.1	30.1	26.1	27.2	27.0	25.3	21.5
98	-	-	-	-	20.9	26.7	22.7	24.0	25.0	23.9	20.1
105	-	-	-	-	-	-	19.1	20.4	22.7	22.2	18.2
111	-	-	-	-	-	-	16.7	18.0	20.0	20.8	17.0
118	-	-	-	-	-	-	-	15.4	17.4	18.9	15.6
124	-	-	-	-	-	-	-	13.4	15.4	16.9	14.6
131	-	-	-	-	-	-	-	11.5	13.3	14.8	13.4
138	-	-	-	-	-	-	-	-	11.4	12.9	12.5
144	-	-	-	-	-	-	-	-	10.2	11.5	11.7
151	-	-	-	-	-	-	-	-	-	10.1	10.1
157	-	-	-	-	-	-	-	-	-	8.9	8.9
164	-	-	-	-	-	-	-	-	-	7.7	7.7
170	-	-	-	-	-	-	-	-	-	-	6.7
177	-	-	-	-	-	-	-	-	-	-	5.7

Boom extension sequence in %

Tele 1	0	23	45	45	90	45	90	90	90	90	100
Tele 2	0	23	45	45	90	45	90	90	90	90	100
Tele 3	0	0	0	45	0	45	45	90	90	90	100
Tele 4	0	0	0	0	0	45	0	0	45	90	100

Lifting capacities main boom

88,000 lb 

 360°

85%

Radius	Main boom													
	48.2 ft	65.6 ft	81.7 ft	98.1 ft	114.8 ft	114.8 ft	114.8 ft	131.6 ft	131.6 ft	148.0 ft	155.1 ft	164.7 ft	181.1 ft	197.0 ft
ft	1,000 lb													
10	327.0	294.0	208.0	-	-	-	-	-	-	-	-	-	-	-
11	310.0	290.0	203.0	-	-	-	-	-	-	-	-	-	-	-
13	281.0	278.0	195.5	-	-	-	-	-	-	-	-	-	-	-
15	255.0	255.0	185.0	146.5	-	-	-	-	-	-	-	-	-	-
16	244.0	244.0	180.0	143.5	-	-	66.5	-	-	-	-	-	-	-
19	217.0	217.0	167.0	135.0	125.5	109.0	62.0	-	66.5	-	-	-	-	-
23	187.0	187.0	150.5	124.0	111.0	101.0	56.1	98.0	60.0	-	-	-	-	-
26	164.5	164.5	140.5	117.0	102.0	96.0	51.9	91.5	56.3	83.0	51.7	-	-	-
29	144.5	144.5	131.5	110.0	94.5	91.0	48.0	85.5	52.4	78.0	49.3	64.5	-	-
33	123.5	122.5	120.0	102.0	85.5	85.5	43.7	79.0	48.1	71.0	46.1	61.5	50.5	39.6
39	-	93.0	92.0	91.0	74.5	76.5	38.4	68.5	42.4	64.0	41.3	56.7	46.7	38.8
46	-	69.0	68.0	71.5	63.5	68.0	33.4	60.0	37.4	56.1	36.3	51.5	42.5	37.6
52	-	56.1	55.5	58.1	54.7	60.5	30.0	53.2	33.8	50.3	32.7	47.3	39.4	36.0
59	-	-	43.9	46.3	43.5	49.4	26.9	45.4	30.4	44.5	29.1	42.8	36.1	33.3
65	-	-	36.6	38.9	36.0	41.7	24.7	38.2	28.0	39.3	26.7	39.1	33.7	30.8
72	-	-	-	32.1	28.8	34.7	22.3	31.0	25.4	32.5	24.3	34.5	31.1	28.0
79	-	-	-	26.5	23.1	29.3	20.4	25.1	23.2	26.7	22.1	29.1	28.9	25.7
85	-	-	-	22.4	19.1	25.3	19.0	21.1	21.6	22.6	20.5	24.9	26.5	23.6
92	-	-	-	-	15.3	21.3	17.6	17.3	20.2	18.6	18.9	20.8	22.6	21.5
98	-	-	-	-	12.7	18.5	16.4	14.5	19.0	15.8	17.7	18.0	19.8	19.7
105	-	-	-	-	-	-	-	11.6	17.6	13.0	16.5	14.9	16.7	16.9
111	-	-	-	-	-	-	-	9.6	16.6	10.9	15.5	12.9	14.5	14.7
118	-	-	-	-	-	-	-	-	-	8.8	14.5	10.8	12.3	12.6
124	-	-	-	-	-	-	-	-	-	7.2	12.9	9.0	10.7	10.7
131	-	-	-	-	-	-	-	-	-	5.5	11.2	7.3	8.8	9.0
138	-	-	-	-	-	-	-	-	-	-	9.6	5.9	7.4	7.4
144	-	-	-	-	-	-	-	-	-	-	-	4.7	6.2	6.2
151	-	-	-	-	-	-	-	-	-	-	-	-	5.0	5.0
157	-	-	-	-	-	-	-	-	-	-	-	-	4.0	4.0
164	-	-	-	-	-	-	-	-	-	-	-	-	3.0	3.0
170	-	-	-	-	-	-	-	-	-	-	-	-	-	2.2

Boom extension sequence in %

Tele 1	0	23	45	45	90	45	0	90	23	90	45	90	90	100
Tele 2	0	23	45	45	90	45	0	90	23	90	45	90	90	100
Tele 3	0	0	0	45	0	45	90	45	90	90	100	90	90	100
Tele 4	0	0	0	0	0	45	90	0	90	0	100	45	90	100

Remarks

Special boom extension sequence

Lifting capacities main boom

72,500 lb 

 360°

85%

Radius	Main boom													
	48.2 ft	65.6 ft	81.7 ft	98.1 ft	114.8 ft	114.8 ft	114.8 ft	131.6 ft	131.6 ft	148.0 ft	155.1 ft	164.7 ft	181.1 ft	197.0 ft
ft	1,000 lb													
10	325.0	294.0	208.0	-	-	-	-	-	-	-	-	-	-	-
11	308.0	290.0	203.0	-	-	-	-	-	-	-	-	-	-	-
13	277.0	276.0	195.5	-	-	-	-	-	-	-	-	-	-	-
15	253.0	253.0	185.0	146.5	-	-	-	-	-	-	-	-	-	-
16	242.0	242.0	180.0	143.5	-	-	66.5	-	-	-	-	-	-	-
19	215.0	215.0	167.0	135.0	125.5	109.0	62.0	-	66.5	-	-	-	-	-
23	181.5	181.5	150.5	124.0	111.0	101.0	56.1	98.0	60.0	-	-	-	-	-
26	156.0	156.0	140.5	117.0	102.0	96.0	51.9	91.5	56.3	83.0	51.7	-	-	-
29	136.5	136.5	131.5	110.0	94.5	91.0	48.0	85.5	52.4	78.0	49.3	64.5	-	-
33	110.0	110.0	109.0	101.5	85.5	85.5	43.7	79.0	48.1	71.0	46.1	61.5	50.5	39.6
39	-	81.0	80.0	82.5	74.5	76.5	38.4	68.5	42.4	64.0	41.3	56.7	46.7	38.8
46	-	59.6	59.1	62.0	58.9	65.5	33.4	60.0	37.4	56.1	36.3	51.5	42.5	37.6
52	-	47.7	47.0	49.7	46.8	53.0	30.0	48.9	33.8	50.1	32.7	47.3	39.4	36.0
59	-	-	36.6	39.3	36.2	42.1	26.9	38.4	30.4	39.9	29.1	42.1	36.1	33.3
65	-	-	30.0	32.6	29.3	35.5	24.7	31.5	28.0	33.1	26.7	35.3	33.7	30.8
72	-	-	-	26.1	22.8	29.2	22.3	25.0	25.4	26.6	24.3	29.0	30.7	28.0
79	-	-	-	21.0	17.9	24.0	20.4	19.9	23.2	21.4	22.1	23.6	25.6	25.6
85	-	-	-	17.5	14.2	20.4	19.0	16.2	21.6	17.8	20.5	20.0	21.8	22.0
92	-	-	-	-	10.9	16.9	17.6	12.9	20.2	14.2	18.9	16.4	18.2	18.4
98	-	-	-	-	8.5	14.5	16.4	10.3	18.6	11.6	17.7	13.8	15.6	15.8
105	-	-	-	-	-	-	-	7.7	16.0	9.2	14.9	11.2	13.0	13.2
111	-	-	-	-	-	-	-	5.8	14.0	7.2	13.1	9.4	10.9	11.2
118	-	-	-	-	-	-	-	-	-	5.3	11.2	7.3	9.0	9.0
124	-	-	-	-	-	-	-	-	-	3.9	9.6	5.8	7.4	7.6
131	-	-	-	-	-	-	-	-	-	2.4	8.2	4.4	6.0	6.0
138	-	-	-	-	-	-	-	-	-	-	6.7	3.0	4.5	4.8
144	-	-	-	-	-	-	-	-	-	-	-	-	3.5	3.6
151	-	-	-	-	-	-	-	-	-	-	-	-	2.4	2.6

Boom extension sequence in %

Tele 1	0	23	45	45	90	45	0	90	23	90	45	90	90	100
Tele 2	0	23	45	45	90	45	0	90	23	90	45	90	90	100
Tele 3	0	0	0	45	0	45	90	45	90	90	100	90	90	100
Tele 4	0	0	0	0	0	45	90	0	90	0	100	45	90	100

Remarks

Special boom extension sequence

Lifting capacities main boom

50,500 lb 

 360°

85%

Radius	Main boom													
	48.2 ft	65.6 ft	81.7 ft	98.1 ft	114.8 ft	114.8 ft	114.8 ft	131.6 ft	131.6 ft	148.0 ft	155.1 ft	164.7 ft	181.1 ft	197.0 ft
ft	1,000 lb													
10	321.0	294.0	208.0	-	-	-	-	-	-	-	-	-	-	-
11	303.0	290.0	203.0	-	-	-	-	-	-	-	-	-	-	-
13	275.0	274.0	195.5	-	-	-	-	-	-	-	-	-	-	-
15	250.0	250.0	185.0	146.5	-	-	-	-	-	-	-	-	-	-
16	240.0	240.0	180.0	143.5	-	-	66.5	-	-	-	-	-	-	-
19	208.0	208.0	167.0	135.0	125.5	109.0	62.0	-	66.5	-	-	-	-	-
23	167.0	166.0	150.5	124.0	111.0	101.0	56.1	98.0	60.0	-	-	-	-	-
26	141.0	140.5	133.5	117.0	102.0	96.0	51.9	91.5	56.3	83.0	51.7	-	-	-
29	113.5	113.0	111.5	108.5	94.5	91.0	48.0	85.5	52.4	78.0	49.3	64.5	-	-
33	86.5	86.0	86.0	89.5	82.0	85.0	43.7	78.5	48.1	71.0	46.1	61.5	50.5	39.6
39	-	62.5	62.0	65.5	61.5	68.0	38.4	63.0	42.4	62.0	41.3	56.7	46.7	38.8
46	-	45.0	44.6	47.5	44.4	51.0	33.4	46.6	37.4	48.3	36.3	49.5	42.5	37.6
52	-	35.4	34.5	37.4	34.3	40.7	30.0	36.5	33.8	38.3	32.7	40.4	39.4	36.0
59	-	-	25.6	28.5	25.2	31.8	26.9	27.6	30.4	29.1	29.1	31.5	33.5	32.8
65	-	-	20.1	22.6	19.5	25.9	24.7	21.7	28.0	23.3	26.7	25.7	27.7	27.4
72	-	-	-	17.3	14.2	20.4	22.3	16.4	25.2	17.9	24.3	20.2	22.1	22.1
79	-	-	-	13.3	10.0	16.1	20.4	12.2	20.8	13.7	19.9	15.9	17.7	17.9
85	-	-	-	10.5	6.9	13.3	19.0	8.9	17.7	10.5	16.9	12.9	14.7	14.9
92	-	-	-	-	4.1	10.3	16.2	6.1	14.7	7.6	13.8	9.8	11.6	11.8
98	-	-	-	-	-	8.3	14.2	3.9	12.5	5.4	11.6	7.6	9.4	9.6
105	-	-	-	-	-	-	-	-	10.3	3.3	9.2	5.5	7.2	7.2
111	-	-	-	-	-	-	-	-	8.7	-	7.6	3.8	5.4	5.6
118	-	-	-	-	-	-	-	-	-	-	5.9	2.2	3.7	3.9
124	-	-	-	-	-	-	-	-	-	-	4.7	-	2.5	2.7
131	-	-	-	-	-	-	-	-	-	-	3.5	-	-	-
138	-	-	-	-	-	-	-	-	-	-	2.6	-	-	-

Boom extension sequence in %

Tele 1	0	23	45	45	90	45	0	90	23	90	45	90	90	100
Tele 2	0	23	45	45	90	45	0	90	23	90	45	90	90	100
Tele 3	0	0	0	45	0	45	90	45	90	90	100	90	90	100
Tele 4	0	0	0	0	0	45	90	0	90	0	100	45	90	100

Remarks

 Special boom extension sequence

Lifting capacities main boom for counterweight page 5

13,500 lb 

 360°

85%

Radius	Main boom													
	48.2 ft	65.6 ft	81.7 ft	98.1 ft	114.8 ft	114.8 ft	114.8 ft	131.6 ft	131.6 ft	148.0 ft	155.1 ft	164.7 ft	181.1 ft	197.0 ft
ft	1,000 lb													
10	312.0	294.0	208.0	-	-	-	-	-	-	-	-	-	-	-
11	296.0	290.0	203.0	-	-	-	-	-	-	-	-	-	-	-
13	268.0	268.0	195.5	-	-	-	-	-	-	-	-	-	-	-
15	238.0	237.0	185.0	146.5	-	-	-	-	-	-	-	-	-	-
16	220.0	215.0	180.0	143.5	-	-	66.5	-	-	-	-	-	-	-
19	169.0	158.0	140.0	126.5	110.0	111.0	62.0	-	66.5	-	-	-	-	-
23	103.0	102.0	98.5	95.5	83.5	93.5	56.1	79.0	60.0	-	-	-	-	-
26	76.0	76.0	75.5	78.5	68.0	77.0	51.9	66.5	56.3	64.5	51.7	-	-	-
29	59.8	59.2	59.0	62.5	57.4	65.5	48.0	56.4	52.4	55.2	49.3	54.7	-	-
33	44.2	43.8	43.6	46.9	43.3	50.6	43.7	44.7	48.0	44.3	46.0	44.6	44.4	39.4
39	-	28.7	28.2	31.5	28.0	35.3	38.4	30.6	40.1	31.6	39.0	33.1	33.7	31.9
46	-	17.7	17.3	20.2	17.1	23.5	29.9	19.3	28.3	20.4	27.4	21.9	22.8	21.7
52	-	12.1	11.3	14.1	11.0	17.0	23.0	13.0	21.7	13.9	20.8	15.7	16.6	15.9
59	-	-	5.5	8.6	5.1	11.7	17.4	7.5	16.1	8.6	15.0	10.1	11.5	10.6
65	-	-	-	4.8	-	8.2	13.8	3.9	12.6	5.2	11.5	6.9	8.0	7.5
72	-	-	-	-	-	4.7	10.6	-	9.3	-	8.2	3.8	4.9	4.4
79	-	-	-	-	-	-	8.3	-	6.7	-	5.6	-	2.5	2.1
85	-	-	-	-	-	-	6.4	-	4.7	-	3.8	-	-	-
92	-	-	-	-	-	-	4.3	-	2.8	-	-	-	-	-
98	-	-	-	-	-	-	3.1	-	-	-	-	-	-	-

Boom extension sequence in %

Tele 1	0	23	45	45	90	45	0	90	23	90	45	90	90	100
Tele 2	0	23	45	45	90	45	0	90	23	90	45	90	90	100
Tele 3	0	0	0	45	0	45	90	45	90	90	100	90	90	100
Tele 4	0	0	0	0	0	45	90	0	90	0	100	45	90	100

Remarks

Special boom extension sequence

Lifting capacities main boom for counterweight page 7

27,500 lb 

 360°

85%

Radius	Main boom													
	48.2 ft	65.6 ft	81.7 ft	98.1 ft	114.8 ft	114.8 ft	114.8 ft	131.6 ft	131.6 ft	148.0 ft	155.1 ft	164.7 ft	181.1 ft	197.0 ft
ft	1,000 lb													
10	316.0	294.0	208.0	-	-	-	-	-	-	-	-	-	-	-
11	299.0	290.0	203.0	-	-	-	-	-	-	-	-	-	-	-
13	270.0	270.0	195.5	-	-	-	-	-	-	-	-	-	-	-
15	245.0	245.0	185.0	146.5	-	-	-	-	-	-	-	-	-	-
16	232.0	232.0	180.0	143.5	-	-	66.5	-	-	-	-	-	-	-
19	192.0	188.5	163.5	135.0	127.0	109.0	62.0	-	66.5	-	-	-	-	-
23	126.0	125.0	123.0	117.5	104.5	101.0	56.1	97.5	60.0	-	-	-	-	-
26	94.0	94.0	93.5	96.5	86.0	95.0	51.9	83.5	56.3	80.0	51.7	-	-	-
29	73.5	73.5	72.5	77.0	71.5	80.5	48.0	71.5	52.4	69.0	49.3	65.0	-	-
33	56.0	55.9	55.4	58.7	55.2	62.0	43.7	57.8	48.1	57.9	46.1	57.7	50.5	39.6
39	-	39.1	38.7	41.6	38.5	44.9	38.4	40.7	42.4	42.4	41.3	44.6	45.0	38.8
46	-	26.5	26.1	29.0	25.9	32.1	33.4	28.1	36.7	29.8	35.8	32.1	33.2	32.1
52	-	19.5	18.8	21.5	18.6	24.6	30.0	20.6	29.0	22.2	28.3	24.4	25.5	24.4
59	-	-	12.8	15.2	12.3	18.1	23.6	14.3	22.3	15.9	21.6	17.6	18.7	18.1
65	-	-	8.7	11.4	7.9	14.0	19.3	10.3	18.0	11.8	17.4	13.4	14.7	14.0
72	-	-	-	7.1	3.8	10.4	15.5	6.0	14.2	7.8	13.5	9.5	10.9	10.2
79	-	-	-	4.0	-	7.1	12.4	2.9	11.3	4.5	10.4	6.7	7.8	7.4
85	-	-	-	-	-	4.7	10.4	-	9.1	-	8.4	4.5	5.8	5.3
92	-	-	-	-	-	2.6	8.5	-	7.0	-	6.1	2.1	3.7	3.2
98	-	-	-	-	-	-	7.1	-	5.4	-	4.5	-	2.3	-
105	-	-	-	-	-	-	-	-	3.7	-	2.8	-	-	-
111	-	-	-	-	-	-	-	-	2.5	-	-	-	-	-

Boom extension sequence in %

Tele 1	0	23	45	45	90	45	0	90	23	90	45	90	90	100
Tele 2	0	23	45	45	90	45	0	90	23	90	45	90	90	100
Tele 3	0	0	0	45	0	45	90	45	90	90	100	90	90	100
Tele 4	0	0	0	0	0	45	90	0	90	0	100	45	90	100

Remarks

Special boom extension sequence

Lifting capacities main boom for counterweight page 7

0 lb



360°

75% / 85%

Radius	Main boom													
	48.2 ft	65.6 ft	81.7 ft	98.1 ft	114.8 ft	114.8 ft	114.8 ft	131.6 ft	131.6 ft	148.0 ft	155.1 ft	164.7 ft	181.1 ft	197.0 ft
ft	1,000 lb													
10	275.0	275.0	208.0	-	-	-	-	-	-	-	-	-	-	-
11	260.0	260.0	203.0	-	-	-	-	-	-	-	-	-	-	-
13	235.0	235.0	195.5	-	-	-	-	-	-	-	-	-	-	-
15	199.0	177.5	150.0	135.5	-	-	-	-	-	-	-	-	-	-
16	182.5	155.5	133.5	122.0	-	-	66.5	-	-	-	-	-	-	-
19	126.5	111.5	97.5	92.0	76.0	86.0	62.0	-	66.5	-	-	-	-	-
23	72.5	72.5	68.0	65.5	56.3	65.5	56.1	53.8	60.0	-	-	-	-	-
26	53.7	53.3	52.8	53.2	44.0	53.2	51.9	43.0	55.3	41.6	49.1	-	-	-
29	40.7	40.1	39.9	42.8	34.8	43.7	48.0	34.7	46.7	34.1	41.4	34.2	-	-
33	27.6	27.4	26.9	30.4	25.6	34.0	41.6	26.1	37.5	26.3	33.4	27.0	27.5	26.2
39	-	16.3	15.8	18.8	15.4	22.1	28.5	16.8	26.8	17.5	24.3	18.8	19.4	18.3
46	-	8.5	7.8	10.7	7.4	13.8	19.3	8.9	18.2	9.8	16.0	11.1	12.0	11.1
52	-	3.7	3.0	5.9	2.8	9.4	14.5	4.5	13.4	5.4	11.4	6.9	7.8	7.1
59	-	-	-	-	-	4.8	10.3	-	9.2	-	7.5	3.1	4.2	3.5
65	-	-	-	-	-	-	7.9	-	6.6	-	4.9	-	-	-
72	-	-	-	-	-	-	5.5	-	4.0	-	2.7	-	-	-
79	-	-	-	-	-	-	3.4	-	-	-	-	-	-	-

Boom extension sequence in %

Tele 1	0	23	45	45	90	45	0	90	23	90	45	90	90	100
Tele 2	0	23	45	45	90	45	0	90	23	90	45	90	90	100
Tele 3	0	0	0	45	0	45	90	45	90	90	100	90	90	100
Tele 4	0	0	0	0	45	90	0	90	0	100	45	90	100	

Remarks

Special boom extension sequence

Working ranges main boom extension, main boom 181.1 ft

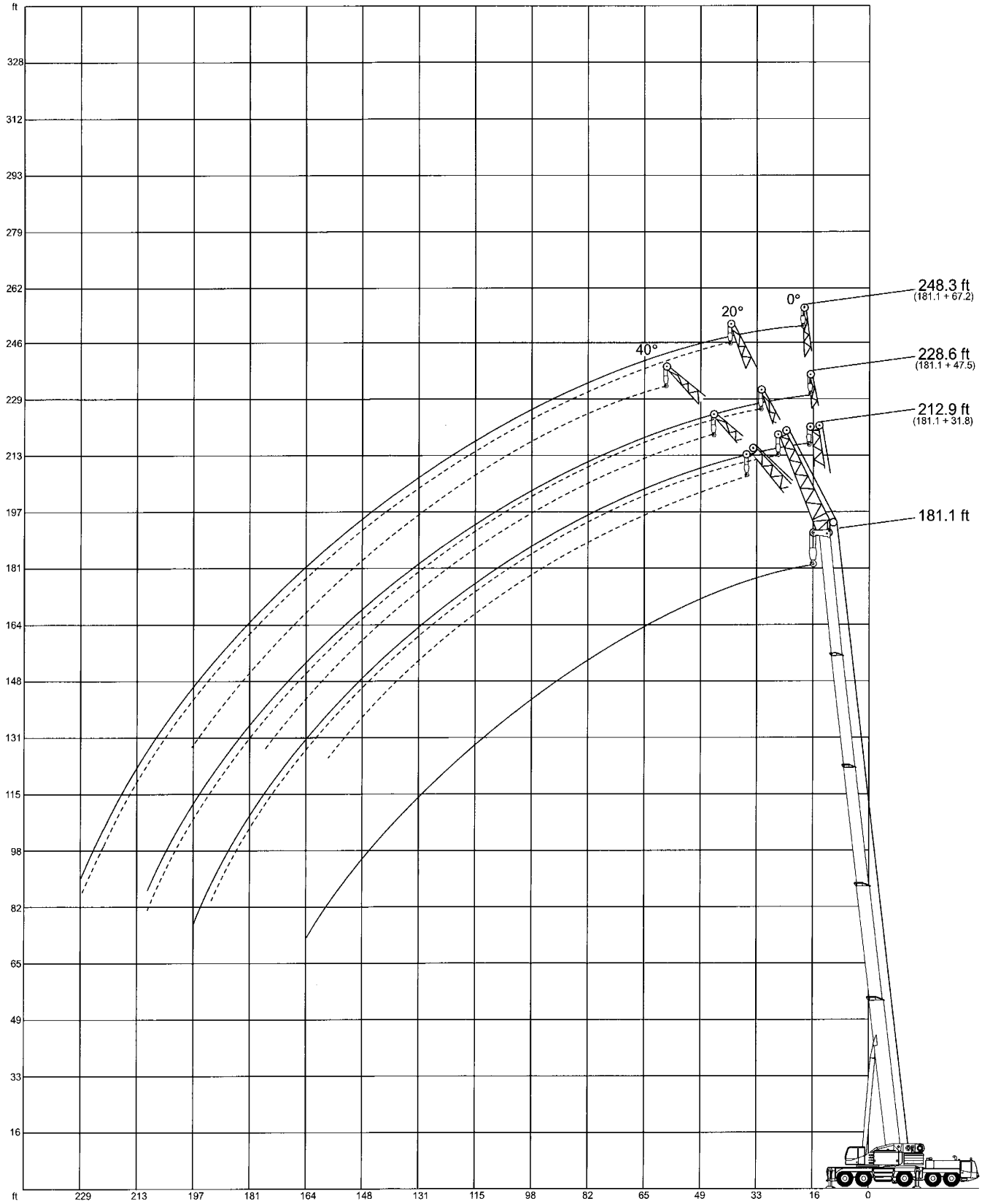

Lifting capacities main boom extension

Main boom: 181.1 ft

141,000 lb   360° 75%/85%

Radius	Extension		
	31.8 ft		
	0°	20°	40°
ft	1,000 lb		
29	29.3	-	-
33	29.2	-	-
39	28.0	24.6	-
46	26.4	24.6	21.3
52	25.2	23.4	21.3
59	23.8	22.2	20.5
65	22.6	21.2	19.7
72	21.2	20.0	18.7
79	20.0	19.1	17.8
85	19.0	18.1	17.0
92	17.8	17.1	16.2
98	17.0	16.1	15.4
105	15.8	15.2	14.7
111	15.0	14.6	14.1
118	14.1	13.6	13.4
124	13.5	13.0	12.8
131	12.8	12.3	12.1
138	11.8	11.6	11.4
144	11.4	11.0	10.8
151	10.7	10.3	10.1
157	10.1	9.7	9.5
164	9.2	9.2	-
170	8.2	8.8	-
177	7.2	7.7	-
184	6.3	6.5	-
190	5.5	5.7	-
197	4.8	-	-

141,000 lb   360° 75%/85%

Radius	Extension		
	47.5 ft		
	0°	20°	40°
ft	1,000 lb		
46	-	18.5	-
52	-	18.5	-
59	20.2	17.4	14.9
65	19.4	16.6	14.9
72	18.3	15.8	14.3
79	17.3	14.9	13.6
85	16.5	14.3	13.2
92	15.6	13.6	12.5
98	15.0	13.2	12.1
105	14.1	12.5	11.6
111	13.5	12.1	11.2
118	12.7	11.4	10.8
124	12.1	11.0	10.4
131	11.4	10.5	9.9
138	10.7	10.1	9.4
144	10.3	9.7	9.2
151	9.6	9.2	8.8
157	9.2	8.8	8.4
164	8.8	8.3	8.1
170	8.4	7.9	7.7
177	7.7	7.5	7.2
184	6.7	7.2	-
190	5.9	6.6	-
197	5.2	5.7	-
203	4.6	4.9	-
210	3.9	4.1	-
216	-	-	-

141,000 lb   360° 75%/85%

Radius	Extension		
	67.2 ft		
	0°	20°	40°
ft	1,000 lb		
33	17.1	-	-
39	17.1	-	-
46	16.7	-	-
52	16.3	-	-
59	15.8	12.3	-
65	15.2	12.3	-
72	14.7	11.9	9.7
79	14.3	11.6	9.6
85	13.6	11.2	9.4
92	13.2	10.7	9.0
98	12.6	10.5	8.8
105	12.1	10.1	8.5
111	11.5	9.7	8.3
118	11.0	9.2	8.1
124	10.6	9.0	7.9
131	9.9	8.6	7.5
138	9.4	8.1	7.2
144	9.0	7.9	7.0
151	8.5	7.4	6.8
157	8.1	7.2	6.6
164	7.7	7.0	6.3
170	7.3	6.6	6.1
177	6.8	6.3	6.1
184	6.5	6.1	5.9
190	6.1	5.9	5.7
197	5.7	5.7	5.5
203	5.1	5.5	-
210	4.4	5.0	-
216	3.8	4.4	-
223	3.3	3.7	-
229	2.7	3.1	-

Working ranges main boom extension, main boom 197.0 ft

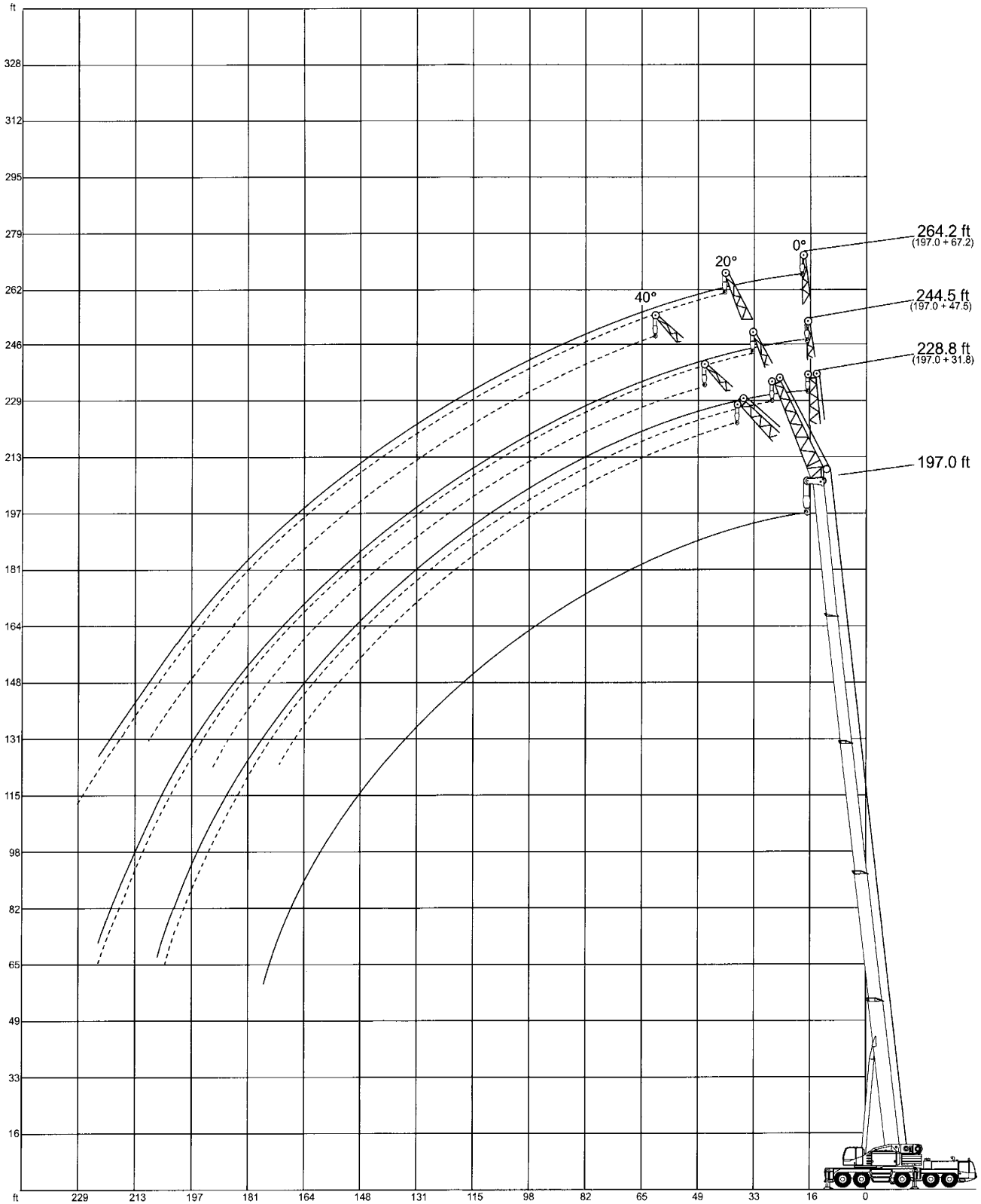

Lifting capacities main boom extension

Main boom: 197.0 ft

141,000 lb   360° 75%/85%

Radius ft	Extension 31.8 ft		
	0°	20°	40°
	1,000 lb		
26	23.5	-	-
29	23.5	-	-
33	23.5	-	-
39	23.5	21.3	-
46	22.6	21.3	17.8
52	21.8	20.5	17.8
59	20.7	19.6	17.8
65	19.9	18.8	17.0
72	18.7	17.6	16.1
79	17.8	16.7	15.3
85	16.8	15.9	14.5
92	15.8	14.7	13.8
98	14.8	13.9	13.0
105	13.8	13.0	12.3
111	12.8	12.1	11.5
118	11.9	11.2	10.8
124	11.1	10.4	10.2
131	10.1	9.5	9.5
138	9.2	8.7	8.7
144	8.6	8.1	8.1
151	7.9	7.4	7.4
157	7.1	6.8	6.8
164	6.3	6.3	6.1
170	5.9	5.7	5.5
177	5.3	5.3	-
184	4.8	4.8	-
190	4.4	4.4	-
197	3.9	4.1	-
203	3.7	3.7	-
210	3.3	-	-

141,000 lb   360° 75%/85%

Radius ft	Extension 47.5 ft		
	0°	20°	40°
	1,000 lb		
39	-	-	-
46	-	14.9	-
52	-	14.9	-
59	16.7	14.9	12.7
65	16.1	14.3	12.7
72	15.4	13.9	12.7
79	14.9	13.2	12.1
85	14.1	12.5	11.7
92	13.4	11.8	11.0
98	12.6	11.2	10.6
105	11.9	10.8	9.9
111	11.2	10.1	9.5
118	10.5	9.4	8.8
124	9.9	9.0	8.4
131	9.2	8.4	7.7
138	8.5	7.9	7.2
144	7.9	7.3	6.8
151	7.2	6.8	6.3
157	6.8	6.4	5.9
164	6.3	5.9	5.5
170	5.9	5.3	5.1
177	5.3	5.0	4.6
184	4.8	4.6	4.3
190	4.4	4.2	3.9
197	3.9	3.7	-
203	3.5	3.5	-
210	3.0	3.3	-
216	2.8	3.1	-
223	2.4	2.8	-
229	-	-	-

141,000 lb   360° 75%/85%

Radius ft	Extension 67.2 ft		
	0°	20°	40°
	1,000 lb		
29	12.5	-	-
33	12.5	-	-
39	12.5	-	-
46	12.5	-	-
52	12.5	-	-
59	12.3	10.5	-
65	11.9	10.5	-
72	11.6	10.3	8.5
79	11.2	9.9	8.5
85	10.8	9.7	8.5
92	10.3	9.2	8.3
98	9.9	9.0	8.1
105	9.4	8.8	7.9
111	9.0	8.4	7.7
118	8.8	8.1	7.2
124	8.4	7.7	7.0
131	7.9	7.2	6.6
138	7.4	7.0	6.3
144	7.0	6.6	5.9
151	6.6	6.1	5.7
157	6.2	5.9	5.3
164	5.7	5.5	5.0
170	5.3	5.1	4.6
177	4.8	4.8	4.4
184	4.6	4.3	3.9
190	4.2	3.9	3.7
197	3.7	3.7	3.5
203	3.3	3.3	3.1
210	3.0	3.0	2.8
216	2.6	2.6	-
223	2.4	2.4	-
229	-	2.2	-

Working ranges main boom extension, main boom 181.1 ft

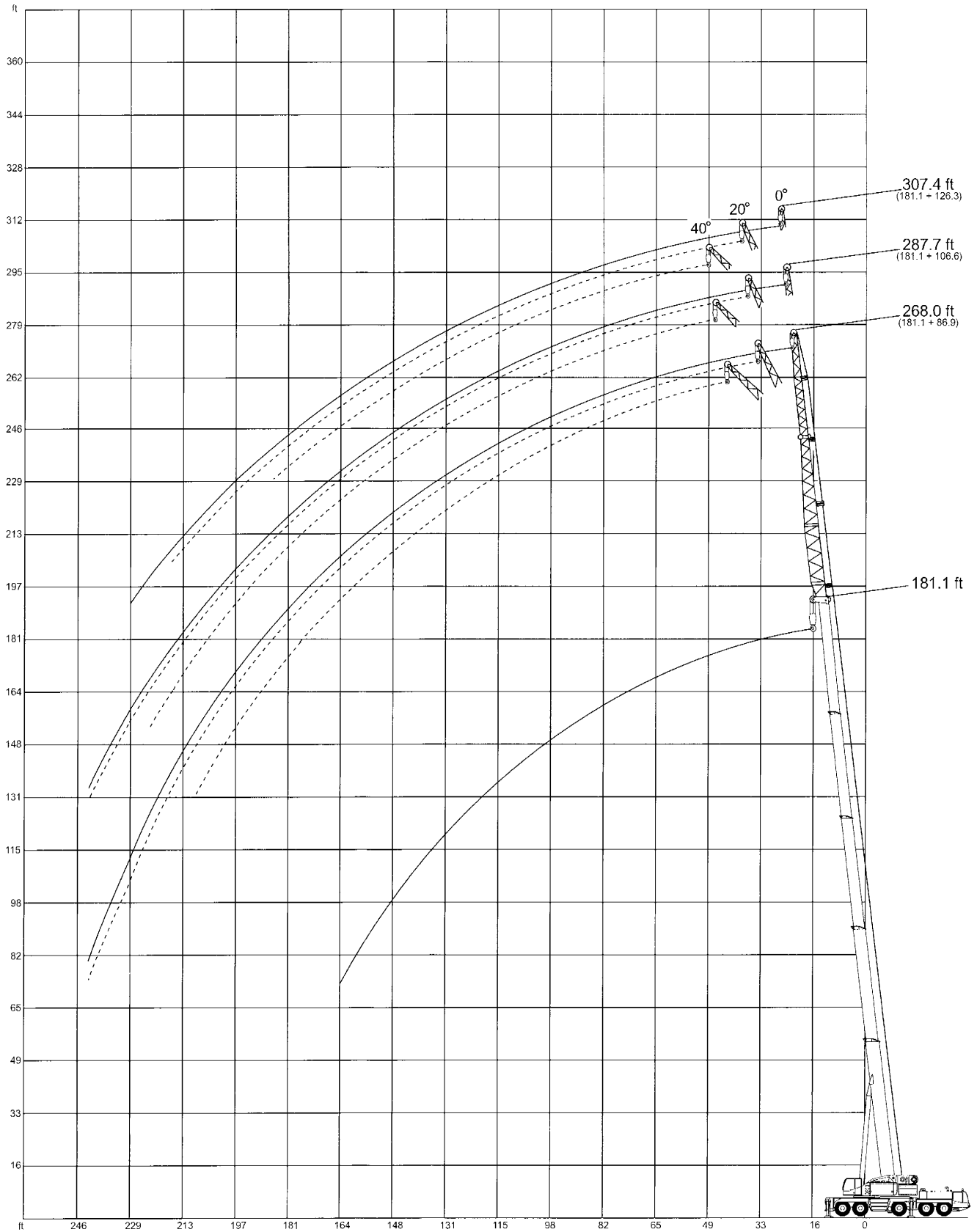

Lifting capacities main boom extension

Main boom: 181.1 ft

141,000 lb   360° 75%/85%

Radius ft	Extension 86.9 ft		
	0°	20°	40°
	1,000 lb		
39	12.1	-	-
46	12.1	-	-
52	11.7	9.0	-
59	11.2	9.0	8.1
65	10.8	8.6	8.1
72	10.3	8.1	7.9
79	10.1	7.9	7.7
85	9.7	7.7	7.7
92	9.2	7.2	7.4
98	9.0	7.0	7.2
105	8.5	6.8	7.0
111	8.3	6.6	6.8
118	8.1	6.3	6.6
124	7.7	6.1	6.6
131	7.5	5.9	6.4
138	7.2	5.7	6.1
144	6.8	5.5	5.9
151	6.6	5.5	5.7
157	6.4	5.3	5.7
164	6.1	5.0	5.5
170	5.9	5.0	5.3
177	5.7	4.8	5.0
184	5.4	4.6	4.8
190	5.0	4.6	4.6
197	4.8	4.4	4.4
203	4.6	4.4	4.2
210	4.4	4.1	3.9
216	4.2	3.9	-
223	3.7	3.9	-
229	3.1	3.5	-
243	2.1	2.4	-

141,000 lb   360° 75%/85%

Radius ft	Extension 106.6 ft		
	0°	20°	40°
	1,000 lb		
39	7.7	-	-
46	7.7	-	-
52	7.7	7.0	-
59	7.7	7.0	-
65	7.5	6.8	5.9
72	7.2	6.8	5.9
79	7.2	6.6	5.9
85	7.0	6.4	5.7
92	6.8	6.3	5.7
98	6.6	6.1	5.5
105	6.6	5.9	5.2
111	6.4	5.9	5.2
118	6.1	5.7	5.0
124	5.9	5.5	4.8
131	5.7	5.2	4.8
138	5.7	5.2	4.6
144	5.5	5.0	4.4
151	5.2	4.8	4.4
157	5.0	4.8	4.2
164	4.8	4.6	4.1
170	4.8	4.4	3.9
177	4.6	4.1	3.7
184	4.4	4.1	3.7
190	4.1	3.9	3.5
197	3.9	3.7	3.3
203	3.9	3.5	3.3
210	3.7	3.5	3.0
216	3.5	3.3	2.8
223	3.3	3.0	2.6
229	3.1	2.8	-
243	2.1	2.4	-

141,000 lb   360° 75%/85%

Radius ft	Extension 126.3 ft		
	0°	20°	40°
	1,000 lb		
46	5.9	-	-
52	5.9	-	-
59	5.7	5.2	-
65	5.5	5.2	4.6
72	5.5	5.0	4.6
79	5.2	4.8	4.4
85	5.0	4.6	4.4
92	4.8	4.4	4.1
98	4.8	4.4	3.9
105	4.6	4.1	3.9
111	4.4	3.9	3.7
118	4.1	3.9	3.5
124	4.1	3.7	3.3
131	3.9	3.5	3.3
138	3.7	3.5	3.0
144	3.7	3.3	2.8
151	3.5	3.0	2.8
157	3.3	3.0	2.6
164	3.3	2.8	2.4
170	3.1	2.8	2.4
177	2.8	2.6	2.2
184	2.8	2.6	2.2
190	2.6	2.4	-
197	2.6	2.4	-
203	2.4	2.2	-
210	2.4	2.2	-
216	2.4	2.2	-
223	2.2	-	-
229	2.2	-	-
243	2.2	-	-

Working ranges main boom extension, main boom 197.0 ft

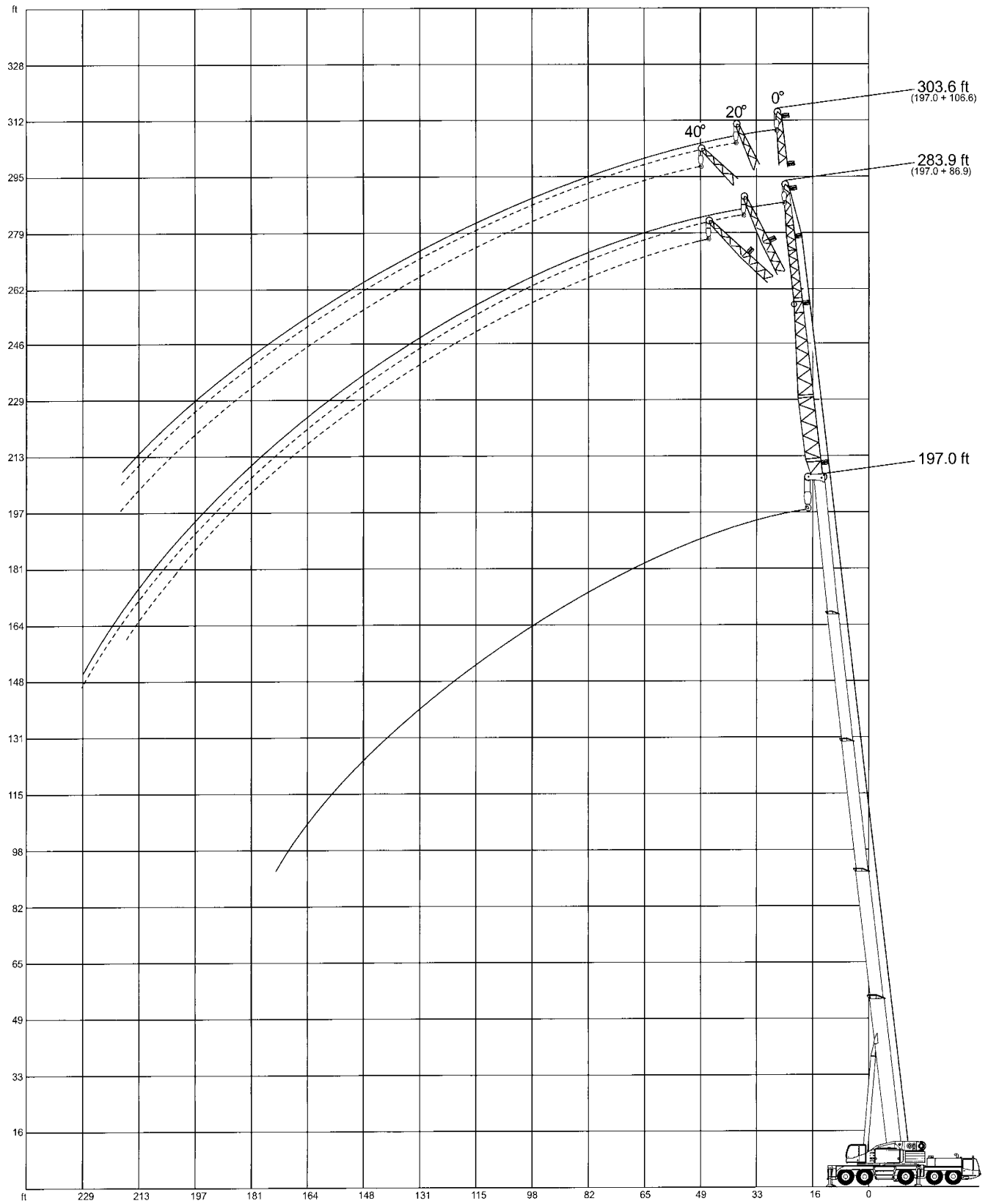

Lifting capacities main boom extension

Main boom: 197.0 ft

141,000 lb   360° 75%/85%

Radius ft	Extension 86.9 ft		
	0°	20°	40°
	1,000 lb		
33	8.5	-	-
39	8.5	-	-
46	8.5	-	-
52	8.5	7.7	-
59	8.5	7.7	6.8
65	8.3	7.7	6.8
72	8.3	7.5	6.8
79	8.1	7.4	6.8
85	7.9	7.2	6.6
92	7.7	7.0	6.6
98	7.5	7.0	6.4
105	7.2	6.8	6.1
111	7.0	6.6	6.1
118	6.8	6.3	5.9
124	6.6	6.1	5.7
131	6.4	5.9	5.5
138	6.1	5.7	5.2
144	5.9	5.5	5.0
151	5.7	5.2	4.8
157	5.3	5.0	4.6
164	5.0	4.8	4.4
170	4.8	4.4	4.2
177	4.6	4.1	3.9
184	4.1	3.9	3.7
190	3.9	3.7	3.5
197	3.5	3.3	3.0
203	3.3	3.1	2.8
210	3.0	2.8	2.6
216	2.6	2.6	2.4
223	2.4	2.4	-
229	2.2	2.2	-

141,000 lb   360° 75%/85%

Radius ft	Extension 106.6 ft		
	0°	20°	40°
	1,000 lb		
33	-	-	-
39	6.3	-	-
46	6.3	-	-
52	6.3	5.9	-
59	6.3	5.9	5.7
65	6.1	5.9	5.7
72	5.9	5.7	5.7
79	5.7	5.7	5.5
85	5.7	5.5	5.3
92	5.5	5.2	5.0
98	5.3	5.0	4.8
105	5.0	4.8	4.8
111	5.0	4.8	4.6
118	4.8	4.6	4.4
124	4.6	4.4	4.4
131	4.4	4.4	4.1
138	4.4	4.1	3.9
144	4.2	3.9	3.9
151	3.9	3.9	3.7
157	3.7	3.7	3.5
164	3.7	3.5	3.5
170	3.5	3.5	3.3
177	3.3	3.3	3.0
184	3.0	3.0	3.0
190	2.8	2.8	2.8
197	2.6	2.8	2.6
203	2.4	2.6	2.6
210	2.4	2.4	2.4
216	2.2	2.2	2.2
223	-	-	-
229	-	-	-

Notes to lifting capacity

Lifting capacities do not exceed 75%/85% of tipping load.

Weight of hook blocks and slings are part of the load, and are to be deducted from the capacity ratings.

Crane operation is permissible up to a
wind speed of 32 ft/s

Consult operation manual for further details on wind speed.

All capacities above the parting line are based on structural strength. Capacities below the parting line are based on machine stability.

Crane operation subject to computer charts, only!

For crane operation consult operation manual first!

Technical description

Carrier

Drive/Steering:	12 x 6 x 8.
Frame:	Demag-built monobox main frame with outrigger boxes integrated, fabricated from high strength fine grain structural steel.
Outriggers:	4-point outrigger system, fully hydraulic horizontal and vertical extension.
Engine:	Daimler-Benz OM 442 LA water-cooled 8-cylinder diesel engine, rating 405 kW (550 hp) at 2100 1/min, torque 2350 Nm at 1100 1/min, fuel tank capacity 132 gallons.
Transmission:	ZF Transmatik transmission with converter (14 speeds forward and 1 reverse), transfer case with differential lockout control.
Axles:	Axles 2, 5 and 6 driven, 1, 2, 5 and 6 steering. Differential lockout control: axles 2, 5 and 6 with transverse lockout; 5th axle with longitudinal lockout.
Suspension:	Hydropneumatic suspension on all axles, all axles hydraulically blockable.
Wheels and tires:	12 disk-type wheels 9.5 – 25/1,7 fitted with 16.00 R 25 tires, tubeless, single wheels.
Steering:	Dual-circuit semiblock mechanical steering with hydraulic booster.
Brakes:	to EC directives. Sustained action brake: constant decompression with butterfly valve, engine exhaust brake, hydraulic retarder.
Electrical equipment:	24 V system.
Driver's cab:	Rubber-mounted all steel low-line cab, ergonomic design, with pneumatically suspended driver's seat and one passenger seat; adjustable steering wheel; heated outside mirrors, electr. adjustable on right-hand side; dashboard with clearly arranged full instrumentation and carrier controls.

Superstructure

Engine:	Daimler-Benz OM 904 LA water-cooled 4-cylinder diesel engine, rating 125 kW (170 hp) at 2300 1/min, torque 660 Nm at 1200 1/min, fuel tank capacity: 80 gallons.
Hydraulic system:	Two variable displacement axial piston pumps with automatic power control and one fixed displacement pump to provide three hydraulic working circuits and three simultaneous working movements, one fixed displacement pump for the low pressure servo control.
Hoist:	Variable displacement axial piston hydraulic motor, hoist drum with integrated planetary gear reducer and brake.
Slew unit:	Axial piston hydraulic motor with planetary gear reducer, pedal-operated brake and spring-applied holding brake.
Boom elevation:	One differential cylinder with pilot-controlled lowering brake valve.
Crane cab:	Spacious all-steel (tiltable) comfortable cab with sliding door and large hinged window, roof window of armoured glass, full instrumentation and crane controls, comfortable seat with ergonomic armrest mounted joystick controls, working light. Self-contained and engine-dependent hot water heater with engine preheating and 7-day programmable timer, thermostat-controlled. Intermittent control window wiper and washer.
Main boom:	Boom base and four telescopic sections fabricated from fine grain structural steel, hydraulically telescoping. Anti-deflection Demag ovaloid design with diagonal self centering slider shoes, hydraulic pin-connection of boom sections.
Counterweight:	88,000 lb.
Safety devices:	Electronic safe load indicator with easy-to-read graphic display and sealed touch-type keyboard, and digital readout for hook load, nominal load, radius, boom length and angle. Analog display to indicate capacity utilization and monitoring code to assist in trouble shooting. Integrated control system for boom telescoping, display for duty charts and theoretical outrigger loading. Further safety devices: limit switches on hoist and lowering motions, pressure relief and safety holding valves, hoist rotation indicator and anemometer.

Optional equipment

Drive/steering:	12 x 8 x 8. Additional 1st axle drive.
5-axle carrier:	Drive/steering 10 x 6 x 8: axles 4 and 5 driven; axles 1, 2, 4 and 5 steering. Differential lockout control: axles 2, 4 and 5 transverse lockout control; 4th axle longitudinal lockout control.
Outrigger loading indicator:	Indication of outrigger loading on carrier and in upper cab.
Eddy-current brake:	Eddy-current brake serves as additional sustained action brake.
Night heater:	Self-contained water heater for carrier cab.
Independent rear axle steering (crab steer):	Rear and front axles are steered independently. The rigid axles are raised hydraulically.
Main boom extension:	Lengths: 31.8 ft, 47.5 ft, 67.2 ft, 86.9 ft, 106.6 ft, 126.3 ft* (*only usable with up to max. 181.1 ft main boom). Max. system lengths: up to 197.0 ft main boom: 197.0 ft + 106.6 ft = 303.6 ft; up to 181.1 ft main boom: 181.1 ft + 126.3 ft = 307.4 ft.
Luffing fly jib:	65.6-190.2 ft, with luffing mast and 9.8 ft adapter, pendant bars, electrical equipment and safety devices (the 2nd hoist drum is required when using the luffing fly jib).
Additional counterweight:	53,000 lb, comprising of 2 x 11,000 lb and 2 x 15,500 lb.
Additional jack leg:	For special duties with 47.5 ft main boom.
Hoist II:	Hoist frame with hoist drum integral. Powered by Hydromatik variable displacement axial piston motor, hoist drum with planetary reducer integral, brake and hoist rope. Hoist II mounts on the rear of the superstructure frame.