

GUAY



GROVE[®]
worldwide



RT745

Rough-Terrain Hydraulic Crane Specifications

Superstructure specifications

Boom	34 ft. to 104 ft. (10.4m - 31.7m) four section trapezoidal boom consisting of a base section, two full power sections and one power pinned section. Telescopic sections slide on adjustable and replaceable Nylatron wear pads. Maximum Tip Height: 112 ft. (34.1m).
Optional Boom	33 ft. to 80 ft. (10.1m-24.4m) three section trapezoidal full power boom consisting of a base section and two full power sections. Telescopic sections slide on adjustable and replaceable Nylatron wear pads. Maximum Tip Height: 88 ft. (26.8m)
Swingaway Extension (4 section boom)	32 ft. (9.8m) lattice swingaway boom extension with integral offset mechanism, offsettable at 0°, 15° or 30°. Stows alongside base boom section when not in use. Maximum Tip Height: 142 ft. (43.3m).
Swingaway Extension (3 section boom)	32 ft. (9.8m) lattice swingaway boom extension stows alongside base boom section. Maximum Tip Height: 120 ft. (36.6m).
Optional Telescopic Swingaway Extension (4 section boom)	32 ft. to 44 ft. or 56 ft. (9.8m to 13.4m or 17.1m) telescopic lattice swingaway extension with integral offset mechanism, offsettable at 0°, 15° or 30°. Stows alongside of base boom section. Maximum Tip Height: 165 ft. (50.3m).
Boom Nose	Four steel sheaves mounted on heavy duty tapered roller bearings with removable pin-type rope guards. *Optional auxiliary boom nose.
Boom Elevation	Dual, double acting hydraulic cylinders with integral holding valves provides elevation from -4° to 76°.
Load Moment & Anti-Two Block System	Standard load moment and anti-two block system with audio-visual warning and control lever lockout. These systems provide electronic display of boom angle, length, radius, tip height, relative load moment, maximum permissible load, load indication and warning of impending two-block conditions.
Cab	Full vision, all steel fabricated with acoustical lining and tinted safety glass throughout. Complete driving controls and engine instrumentation. Dash mounted control levers for all craning functions. Other standard features include: hinged skylight, sliding left side door and sliding right side window, electric windshield washer-wiper, propane heater, circulating air fan, fire extinguisher, seat belt.
Swing	Ball bearing swing circle with 360° continuous rotation. Grove planetary glide-swing with foot applied multi-disc brake. Spring applied hydraulically released parking brake and plunger type one-position mechanical house lock operated from cab. Maximum speed: 2.6 RPM.
Counterweight	Integral with turntable mast. 11,000 lbs. (4989 kg) with main hoist only. 9,250 lbs. (4195 kg) with main and auxiliary hoists.

HYDRAULIC SYSTEM

Pumps	4 main gear pumps, combined capacity 146 GPM (553 LPM) driven by carrier engine through P.T.O. Standard pump disconnect.
Valves	Precision four way double acting control valves, 4 individual valve banks permit simultaneous control of multiple crane functions.
Filter	Return line type, full flow with bypass protection and service indicator. Replaceable cartridge, with micron filtration rating of 15/30/38.
Reservoir	154 gallons (583 L) with spin-on breather filter, external sight gauge, clean out access, strap mounted to frame.
Oil Cooler	Remote mounted with Cummins and radiator mounted with Caterpillar.
Pressure Check Panel	System pressure test panel permits easy verification of circuit pressures.

HOIST SPECIFICATIONS

Power up and down equal speed, planetary reduction with automatic spring applied multi-disc brake. Electronic hoist drum rotation indicator and hoist drum cable follower.

Main and *Auxiliary Hoist Grove HO30B-16

Make/Model		High Range	Low Range
Maximum single line speed	Bottom layer	386 FPM (118m/min)	193 FPM (59m/min)
	Intermediate layer	448 FPM (137m/min)	224 FPM (68m/min)
	Top layer	510 FPM (155m/min)	255 FPM (78m/min)
Maximum single line pull	Bottom layer	8,161 lbs. (3702 kg)	16,322 lbs. (7402 kg)
	Intermediate layer	7,028 lbs. (3187 kg)	14,056 lbs. (6375 kg)
	Top layer	6,172 lbs. (2799kg)	12,344 lbs. (5598 kg)
Maximum permissible line pull		12,920 lbs. (5860 kg)	
w/5:1 strength factor		3/4 in. (19mm) 18x19 class	
Maximum rope stowage		508 ft. (155m) 3/4 in (19mm)	
		Note: 500 ft. (152.4m) of wire rope supplied with standard unit.	

*Denotes optional equipment

Carrier specifications

Frame	High strength alloy steel all welded box-type construction with integral outrigger housings and front/rear lifting, towing and tie down lugs.
Outrigger System	Hydraulic single stage double box telescopic beam and jack outriggers with integral holding valves. All steel fabricated quick release type outrigger floats, 24" (610mm) diameter. Maximum outrigger pad load 67,539 lbs. (30,636 kg).
Outrigger Controls	Located in cab on right side console requires two hand operation. Crane level indicator located in cab.
Engine	Cummins 6BTA5.9 six cylinder turbo-charged water cooled diesel - 5.9 L, 192 bhp (143 kw) (Gross) @ 2,800 RPM. Maximum torque 458 ft. lbs. (63 kg/m) @ 1,700 RPM.
Optional Engine	CAT 3208 eight cylinder naturally aspirated water cooled diesel , 195 bhp (145 kw) (Gross) @ 2,600 RPM. Maximum torque 489 ft. lbs. (68 kg/m) @ 1,200 RPM.
Fuel Tank Capacity	60 gallons (227 L)
Electrical System	Two (four with CAT) 12 volt maintenance free batteries, 625 CCA @ 0° degree F. 24 volt starting.
Drive	4 x 4
Steering	Fully independent power steering: Front: Full hydraulic controlled by steering wheel. Rear: Full hydraulic hand lever controlled. Provides infinite variations of 4 main steering modes - front only, rear only, crab and coordinated. Rear wheel steer indicator.
Transmission	Remote mounted powershift with 6 speeds forward and 6 reverse, 3 in high range, 3 in low range. Rear axle disconnect for 4 x 2 travel.
Axles	Front: Drive-steer with differential and planetary reduction hubs rigid mounted to the chassis. Rear: Drive-steer with differential and planetary reduction hubs, pivot mounted at the center of chassis frame, providing up to 10" (254mm) oscillation. Optional: *No-spin differential on rear axle.
Oscillation Lockouts	Automatic full hydraulic lockouts on rear axle permits oscillation only with boom centered over the front. *Optional oscillation lockout override control.
Tires	Standard 21.00 x 25-24PR earthmover type tubeless.
Optional Tires	*26.5 x 25-26PR earthmover type tubeless;
Tires	29.5 x 25-22PR earthmover type tubeless.
Brakes	Dual braking system, full air operating on all four wheels. Spring-applied, air released parking brake operating on all four wheels.
Lights	Full lighting package including turn indicators, head, tail, brake and hazard warning lights.
Maximum Speed	20.3 MPH (32.7 kph)

Maximum Gradeability	128% theoretical based on 84,500 lbs. (38,329 kg) GVW. 21.00 x 25 tires, pump disengaged, 80 ft. (24.4m) boom plus 32 ft. (9.8m) swingaway.
Gross Vehicle Weight & Axle Loads	BASIC STANDARD MACHINE (3 Section Boom) Front: 36,845 lbs. (16,713 kgs) Rear: 41,855 lbs. (18,985 kgs) G.V.W.: 78,700 lbs. (35,698 kgs) BASIC STANDARD MACHINE (4 Section Boom) Front: 40,108 lbs. (18,193 kgs) Rear: 40,592 lbs. (18,413 kgs) G.V.W. 80,700 lbs. (36,606 kgs)
Miscellaneous Standard Equipment	Full width steel fenders, dual rear view mirrors, hookblock tiedown, electronic back-up alarm, light package, front stowage well.
Optional Equipment	* Auxiliary hoist * Worklights * 360° rotating beacon * Cab spotlight * Outrigger spin locks * Engine block heater * Manual skylight wiper * Hookblocks * Tow winch (front mounted-maximum single line pull - 15,000 lbs. [6804 kg]; maximum speed - 92 FPM [28.0 m/m]) * Spare wheel assembly * Tire inflation kit * Tool kit * Pintle hook front/rear * Diesel heater/defroster

*Denotes optional equipment.

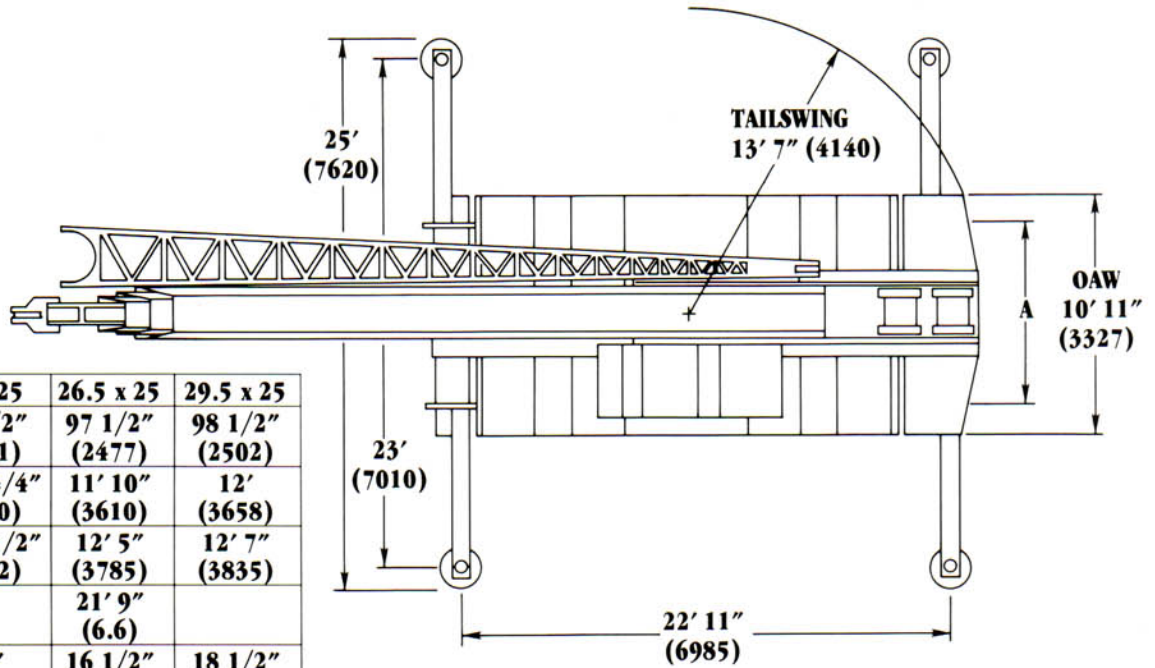

TIRE SIZE	21 x 25	26.5 x 25	29.5 x 25
A (Track)	96 1/2" (2451)	97 1/2" (2477)	98 1/2" (2502)
B (OAH)	11' 9 3/4" (3600)	11' 10" (3610)	12' (3658)
C	12' 4 1/2" (3772)	12' 5" (3785)	12' 7" (3835)
Turning Radius		21' 9" (6.6)	
Ground Clearance	16" (406)	16 1/2" (419)	18 1/2" (470)

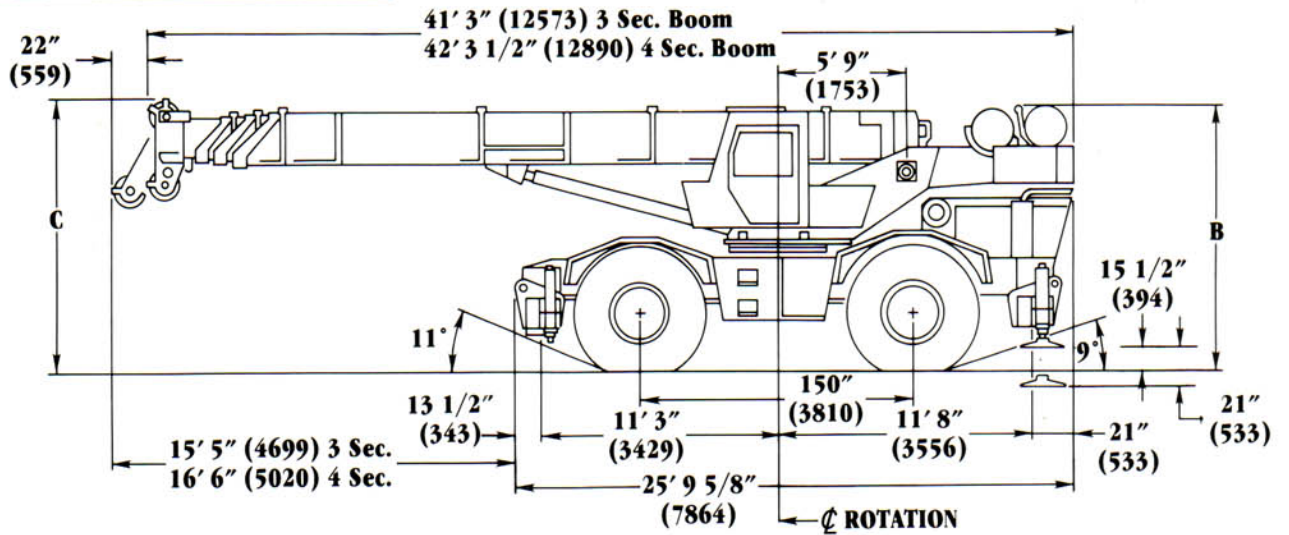



GROVE®
worldwide

RT745

Rough terrain hydraulic crane/85% Domestic
34 ft.-104 ft. powered pinned boom

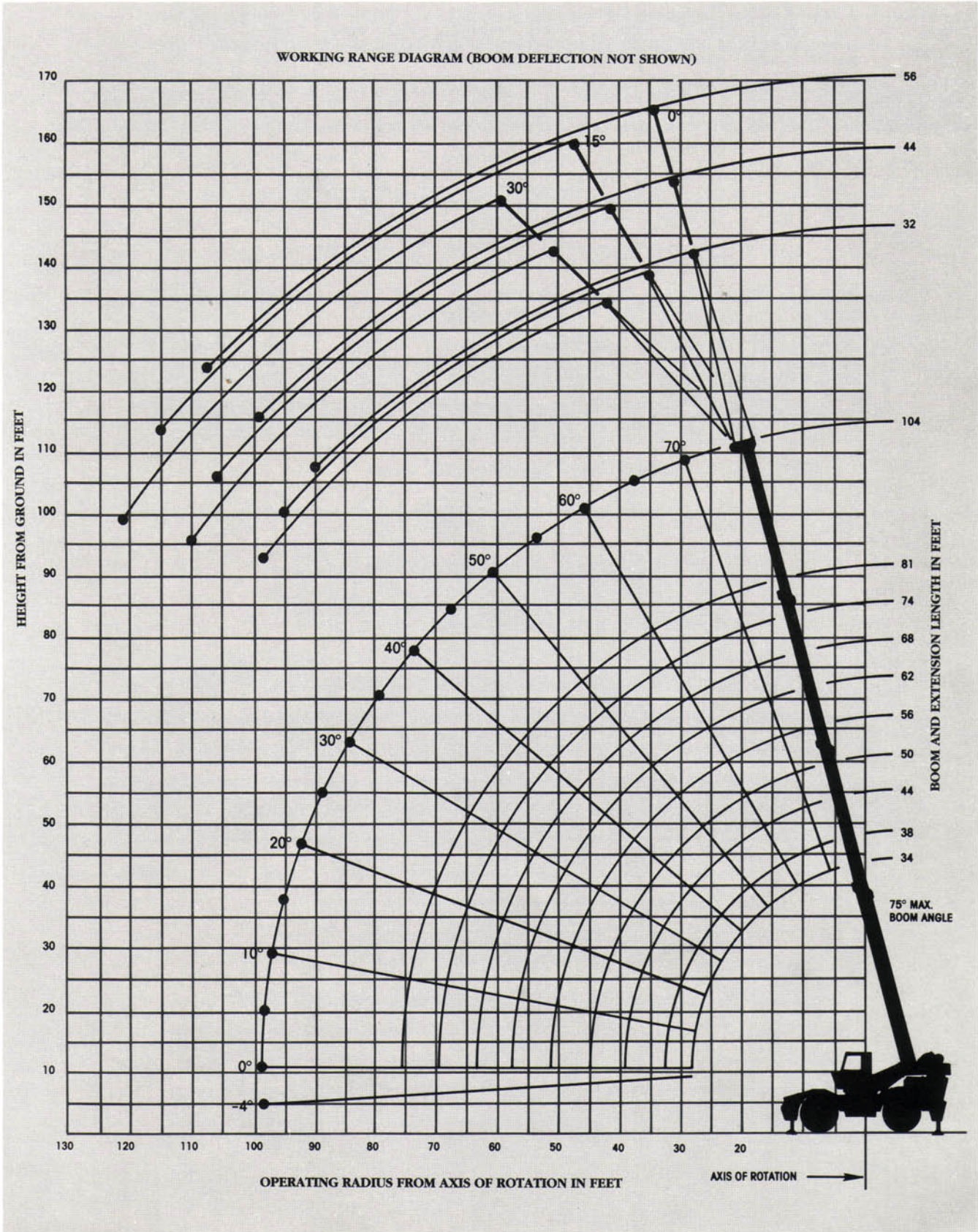

NOTES FOR LIFTING CAPACITIES

WARNING: THIS CHART IS ONLY A GUIDE. The Notes below are for illustration only and should not be relied upon to operate the crane. The individual crane's load chart, operating instructions and other instruction plates must be read and understood prior to operating the crane.

- All rated loads have been tested to and meet minimum requirements of SAE J1063 OCT80 - Cantilevered Boom Crane Structures - Method of Test, and do not exceed 85% of the tipping load on outriggers (75% of the tipping load on rubber) as determined by SAE J765 OCT 80 Crane Stability Test Code.
- Capacities given do not include the weight of hookblocks, slings, auxiliary lifting equipment and load handling devices. Their weights **MUST** be added to the load to be lifted. When more than minimum required reeving is used, the additional rope weight shall be considered part of the load.
- Defined Arc $\pm 6^\circ$ on either side of longitudinal centerline of machine.
- Capacities appearing above the bold line are based on structural strength and tipping should not be relied upon as a capacity limitation.
- All capacities are for crane on firm, level surface. It may be necessary to have structural supports under the outrigger floats or tires to spread the load to a larger bearing surface.
- When either boom length or radius or both are between values listed, the smallest load shown at either the next larger radius or boom length shall be used.
- Tires shall be inflated to the recommended pressure before lifting on rubber
- For outrigger operation, ALL outriggers shall be fully extended with tires raised free of ground before raising the boom or lifting loads.
- Unless otherwise stated, capacities are with powered boom sections equally extended.
- With tele boom extension in working position and main boom length greater than 81 ft., boom angle must not be less than 30° , since loss of stability will occur causing a tipping condition.

Constant improvement and engineering progress make it necessary that we reserve the right to make specification, equipment, and price changes without notice. Illustrations shown may include optional equipment and accessories and may not include all standard equipment.



Grove Worldwide - World Headquarters
 1565 Buchanan Trail East
 Shady Grove, Pennsylvania 17256
 Phone: (717) 597-8121 Telex: 1842308 Fax: (717) 597-4062

Grove North America
 P.O. Box 21, Shady Grove, Pennsylvania 17256
 Western Hemisphere, Asia/Pacific
 Phone: (717) 597-8121 Telex: 1842308 Fax: (717) 597-4062

Grove Europe*
 Sunderland, England SR4 6TT
 Europe, Africa, Middle East, Near East
 Phone: (091) 565-6281 Telex: 53484 CRANESG FAX: (091) 564-0442
 *Grove Europe Limited, Registered in England, Number 1845128, Registered office, Crown Works, Pallion, Sunderland, Tyne & Wear, England SR4 6TT.

ON RUBBER 21.00X25 - 24 PLY TIRES (STATIONARY - DEFINED ARC OVER FRONT)

Radius in Feet	#9005								
	Main Boom Length in Feet								
	34	38	44	50	56	62	68	74	81
10	64,000 (63.5)	41,900 (67)							
12	58,350 (60)	36,000 (63.5)							
15	50,500 (53.5)	29,450 (58.5)	25,450 (63.5)						
20	32,400 (42)	24,500 (49)	21,950 (55.5)	21,950 (60.5)					
25	21,600 (26)	21,600 (37.5)	17,950 (47)	16,950 (53.5)	16,950 (58)	16,950 (62)			
30		15,850 (21.5)	15,850 (37)	13,400 (46)	13,400 (52)	13,400 (56.5)	13,400 (60)	13,400 (63)	13,400 (66)
35			11,850 (23.5)	10,700 (37)	10,700 (45)	10,700 (50.5)	10,700 (55)	10,700 (58.5)	10,700 (62)
40				9,080 (25.5)	8,600 (37)	8,600 (44)	8,600 (49.5)	8,600 (53.5)	8,600 (58)
45					7,010 (26.5)	7,010 (36.5)	6,900 (43.5)	6,900 (48.5)	6,900 (53.5)
50					5,420 (8)	5,420 (27.5)	5,420 (36.5)	5,420 (43)	5,420 (48.5)
55						4,160 (13)	4,160 (28.5)	4,160 (36.5)	4,160 (43.5)
60							3,130 (16.5)	3,130 (29)	3,130 (37.5)
65								2,280 (19)	2,280 (31)
70									1,570 (22.5)

A6-829-009321

ON RUBBER (STATIONARY CAPACITIES - 360°)

Radius in Feet	#9005							
	Main Boom Length in Feet							
	34	38	44	50	56	62	68	74
10	46,700 (63.5)	29,800 (67)						
12	36,550 (60)	25,000 (63.5)						
15	26,450 (53.5)	19,600 (58.5)	19,600 (63.5)					
20	16,800 (42)	16,800 (49)	13,850 (55.5)	13,850 (60.5)				
25	11,250 (28)	11,250 (37.5)	11,250 (47)	9,980 (53.5)	9,980 (58)	9,980 (62)		
30		7,640 (21.5)	7,640 (37)	7,640 (46)	7,280 (52)	7,280 (56.5)	7,280 (60)	7,280 (63)
35			5,290 (23.5)	5,290 (37)	5,290 (45)	5,270 (50.5)	5,270 (55)	5,270 (58.5)
40				3,590 (25.5)	3,590 (37)	3,590 (44)	3,590 (49.5)	3,590 (53.5)
45					2,310 (28.5)	2,310 (36.5)	2,310 (43.5)	2,310 (48.5)
50					1,300 (8)	1,300 (27.5)	1,300 (36.5)	1,300 (43)

A6-829-009322

PICK & CARRY CAPACITIES (UP TO 2.5 MPH) BOOM CENTERED OVER FRONT

Radius in Feet	#9008								
	Main Boom Length in Feet								
	34	38	44	50	56	62	68	74	81
10	56,500 (63.5)	39,900 (67)							
12	49,100 (60)	34,500 (63.5)							
15	40,650 (53.5)	28,400 (58.5)	28,400 (63.5)	28,400 (67)					
20	30,900 (42)	21,300 (49)	21,300 (55.5)	21,300 (60.5)	21,300 (64)	21,300 (67)	21,300 (69.5)		
25	21,600 (28)	16,600 (37.5)	16,600 (47)	16,600 (53.5)	16,600 (58)	16,600 (62)	16,600 (66)		
30		15,850 (21.5)	13,100 (37)	13,100 (46)	13,100 (52)	13,100 (56.5)	13,100 (60)		
35			11,850 (23.5)	10,500 (37)	10,500 (46)	10,500 (50.5)	10,500 (55)	10,500 (58.5)	10,500 (62)
40				9,080 (25.5)	8,500 (37)	8,500 (44)	8,500 (49.5)	8,500 (53.5)	8,500 (58)
45					7,010 (26.5)	6,800 (36.5)	6,800 (43.5)	6,800 (48.5)	6,800 (53.5)
50					5,420 (8)	5,400 (27.5)	5,400 (36.5)	5,400 (43)	5,400 (48.5)
55						4,160 (13)	4,160 (28.5)	4,160 (36.5)	4,160 (43.5)
60							3,130 (16.5)	3,130 (29)	3,130 (37.5)
65								2,280 (19)	2,280 (31)
70									1,570 (22.5)

NOTE: Boom angles are in degrees.

A6-829-009323

NO LOAD STABILITY ON RUBBER

	No Load Stability Data	Main Boom Fly Ret.
Front (No load)	Min. boom angle (deg.) for indicated length	0
	Max. boom length (ft.) at 0 deg. boom angle	81
360 Deg. (No load)	Min. boom angle (deg.) for indicated length	47
	Max. boom length (ft.) at 0 deg. boom angle	62

32 FT. SWINGAWAY - 360°

Main Boom Angle (Deg.)	0° OFFSET	15° OFFSET	30° OFFSET
POWER PINNED FLY RETRACTED			
	#0051	#0052	#0053
75	18,200 (25.5)	10,300 (31.6)	6,900 (36.6)
70	14,900 (34.6)	9,000 (40.4)	6,400 (45.0)
65	12,200 (43.4)	8,000 (48.9)	6,100 (53)
60	10,200 (51.8)	7,100 (57.0)	5,600 (60.6)
55	8,800 (59.8)	6,600 (64.6)	5,400 (67.6)
50	7,900 (67.4)	6,100 (71.7)	5,100 (74.1)
45	7,020 (74.4)	5,700 (78.2)	5,000 (80)
POWER PINNED FLY EXTENDED			
	#0055	#0056	#0057
75	11,000 (35.8)	8,500 (41.6)	6,400 (46.0)
70	9,200 (46.6)	7,500 (52.2)	5,900 (56.4)
65	7,800 (57.1)	6,500 (62.4)	5,500 (66.2)
60	6,600 (67.2)	5,700 (72.1)	5,100 (75.6)
55	5,700 (76.7)	5,000 (81.3)	4,700 (84.3)
50	5,000 (85.7)	4,400 (89.8)	4,200 (92.4)
45	4,220 (94.0)	3,700 (97.6)	3,410 (99.8)

A6-829-008562 & 008563

MAIN BOOM ON OUTRIGGERS FULLY EXTENDED - 360°

Radius in Feet	#0001										#0002
	Main Boom Length in Feet (Power Pinned Fly Retracted)										Power Pin. Fly Ext. @ 81 ft.
	34	38	44	50	56	62	68	74	81	104	
10	90,000 (63.5)	73,750 (67)	69,950 (70.5)	68,200 (73)	63,350 (75)						
12	75,000 (60)	73,750 (63.5)	66,700 (67.5)	61,600 (70.5)	57,150 (73)	53,750 (75)					
15	62,000 (53.5)	62,000 (58.5)	58,050 (63.5)	54,000 (67)	51,000 (70)	46,650 (72)	43,850 (74)	40,850 (75.5)			
20	47,300 (42)	47,300 (49)	47,300 (55.5)	43,950 (60.5)	40,550 (64)	38,000 (67)	35,700 (69.5)	33,100 (71.5)	30,000 (74)		
25	36,000 (26)	36,000 (37.5)	36,000 (47)	36,000 (53.5)	34,050 (58)	31,800 (62)	29,900 (65)	27,600 (67)	25,200 (70)	21,800 (75.5)	
30		29,000 (21.5)	29,000 (37)	29,000 (46)	29,000 (52)	27,100 (56.5)	25,600 (60)	23,500 (63)	21,500 (66)	18,800 (72.5)	
35			23,800 (23.5)	23,800 (37)	23,800 (45)	23,500 (50.5)	22,250 (55)	20,350 (58.5)	18,650 (62)	16,400 (69.5)	
40				19,200 (25.5)	19,200 (37)	19,200 (44)	19,200 (49.5)	17,800 (53.5)	16,200 (58)	14,500 (66.5)	
45					15,900 (26.5)	15,900 (36.5)	15,900 (43.5)	15,750 (48.5)	14,250 (53.5)	12,750 (63.5)	
50					13,150 (8)	13,150 (27.5)	13,150 (36.5)	13,150 (43)	12,600 (48.5)	11,300 (60.5)	
55						11,200 (13)	11,200 (28.5)	11,200 (36.5)	11,200 (43.5)	10,000 (57)	
60							9,560 (16.5)	9,560 (29)	9,560 (37.5)	9,060 (53.5)	
65								8,000 (19)	8,000 (31)	8,150 (50)	
70									6,670 (22.5)	7,360 (46)	
75										6,660 (42)	
80										6,040 (37)	
85										5,380 (17)	
90										4,450 (25.5)	
95										3,580 (17)	
Minimum boom angle (deg.) for indicated length (no load)										0	0
Maximum boom length (ft.) at 0 deg. boom angle (no load)										81	104

A6-829-008671

WEIGHT REDUCTION FOR LOAD HANDLING DEVICES

32 ft. Extension with 34 ft. - 104 ft. Boom	
*Stowed-	884 lbs.
*Erected -	5,730 lbs.

32 ft. - 56 ft. Tele. Ext. with 34 ft.-104 ft. Boom	
*Stowed -	1,038 lbs.
*Erected (ret) -	7,268 lbs.
*Erected (ext) -	9,367 lbs.

AUXILIARY BOOM HEAD		220 lbs.
HOOKBLOCKS & HEADACHE BALLS:		
15 Ton, 1 Sheave		400 lbs.
45 Ton, 3 Sheave		1,100 lbs.
7.5 Ton Headache Ball		338 lbs.
10 Ton Headache Ball		560 lbs.

DIMENSIONS ARE FOR LARGEST GROVE FURNISHED HOOK BLOCK AND HEADACHE BALL, WITH ANTI-TWO BLOCK ACTIVATED.

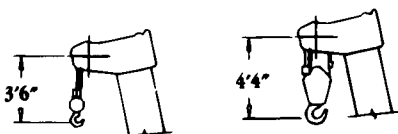

32 FT. - 56 FT. TELE. SWINGAWAY - 360°

Main Boom Angle (Deg.)	32 ft. LENGTH			44 ft. LENGTH			56 ft. LENGTH		
	0° OFFSET	15° OFFSET	30° OFFSET	0° OFFSET	15° OFFSET	30° OFFSET	0° OFFSET	15° OFFSET	30° OFFSET
POWER PINNED FLY RETRACTED									
	#0021	#0022	#0023	#0031	#0032	#0033	#0041	#0042	#0043
75	17,500 (25.5)	9,600 (31.6)	6,500 (36.6)	11,700 (30.3)	6,400 (40.0)	4,500 (47.3)	8,900 (35.1)	4,800 (48.5)	3,200 (57.1)
70	14,200 (34.6)	8,300 (40.4)	5,800 (45.0)	9,400 (40.5)	5,200 (49.8)	3,900 (56.4)	7,100 (46.1)	4,200 (58.9)	2,800 (66.8)
65	11,500 (43.4)	7,300 (48.9)	5,400 (53.0)	7,700 (50.3)	4,800 (59.1)	3,700 (65.1)	5,700 (56.8)	3,600 (68.8)	2,600 (76.0)
60	9,500 (51.8)	6,500 (57.0)	5,000 (60.6)	6,400 (59.7)	4,500 (68.0)	3,600 (73.3)	4,800 (67.0)	3,200 (78.2)	2,500 (84.6)
55	8,100 (59.8)	5,900 (64.6)	4,700 (67.6)	5,200 (68.7)	4,100 (76.4)	3,400 (80.9)	4,000 (76.7)	2,800 (87.0)	2,400 (92.5)
50	7,200 (67.4)	5,400 (71.7)	4,400 (74.1)	4,800 (77.1)	3,800 (84.1)	3,300 (87.8)	3,400 (85.8)	2,600 (95.1)	2,300 (99.6)
45	6,500 (74.4)	5,000 (78.2)	4,300 (80.0)	4,500 (84.9)	3,600 (91.2)	3,200 (94.0)	3,200 (94.2)	2,500 (102.4)	2,200 (106.0)
POWER PINNED FLY EXTENDED									
	#0025	#0026	#0027	#0035	#0036	#0037	#0045	#0046	#0047
75	10,300 (35.8)	7,800 (41.6)	6,000 (46.0)	8,700 (41.5)	5,800 (50.9)	4,200 (57.7)	7,000 (47.4)	4,400 (58.6)	3,000 (67.3)
70	8,500 (46.6)	6,800 (52.2)	5,300 (56.4)	7,100 (53.3)	5,200 (62.5)	3,900 (68.6)	5,900 (60.0)	3,800 (70.9)	2,700 (78.7)
65	7,100 (57.1)	5,800 (62.4)	4,800 (66.2)	5,900 (64.8)	4,600 (73.6)	3,700 (79.0)	5,000 (72.2)	3,300 (82.6)	2,500 (89.5)
60	5,900 (67.2)	5,100 (72.1)	4,500 (75.6)	4,900 (75.8)	4,100 (84.2)	3,400 (88.7)	4,200 (83.9)	3,000 (93.8)	2,400 (99.6)
55	5,000 (76.7)	4,300 (81.3)	4,000 (84.3)	4,000 (86.3)	3,600 (94.1)	3,000 (97.8)	3,400 (95.0)	2,600 (104.3)	2,100 (109.0)
50	4,300 (85.7)	3,700 (89.8)	3,500 (92.4)	3,400 (96.1)	3,100 (103.3)	2,700 (106.1)	2,700 (105.4)	2,400 (114.0)	2,000 (117.5)
45	3,500 (94.0)	3,200 (97.6)	2,900 (99.8)	2,900 (105.3)	2,460 (111.8)	2,290 (113.6)	2,400 (115.0)	2,160 (122.9)	1,900 (125.1)

A6-829-008232

ZERO DEGREE BOOM ANGLE CHARTS

ON OUTRIGGERS - 360°

Boom Angle	Main Boom Length in Feet									
	34	38	44	50	56	62	68	74	81	104
0°	20,250 (28)	17,050 (32.3)	13,650 (38.3)	11,000 (44.3)	9,010 (50.3)	7,370 (56.3)	6,020 (62.3)	4,900 (68.3)	3,860 (74.8)	2,670 (98.2)

ON RUBBER 21.00 x 25 TIRES

Stationary Capacity Defined Arc (3) Over Front

Boom Angle	Main Boom Length in Feet								
	34	38	44	50	56	62	68	74	74
0°	17,900 (28)	13,850 (32.3)	9,960 (38.3)	7,290 (44.3)	5,350 (50.3)	3,880 (56.3)	2,730 (62.3)	1,800 (68.3)	1,800 (68.3)

Stationary Capacity 360° Arc

Boom Angle	Main Boom Length in Feet				
	34	38	44	50	56
0°	8,920 (28)	6,480 (32.3)	4,130 (38.3)	2,480 (44.3)	1,260 (50.3)

Pick & Carry Capacities Up to 2.5 MPH Boom Centered (7) Over Front

Boom Angle	Main Boom Length in Feet									
	34	38	44	50	56	62	68	74	81	81
0°	17,900 (28)	11,200 (32.3)	9,470 (38.3)	6,860 (44.3)	5,170 (50.3)	3,750 (56.3)	2,670 (62.3)	1,780 (68.3)	1,050 (74.8)	1,050 (74.8)

9380

Note: () Reference radii in feet

Refer to in-cab load chart for notes.

ON RUBBER 26.5 x 25 TIRES

Stationary Capacity Defined Arc (3) Over Front

Boom Angle	Main Boom Length in Feet							
	34	38	44	50	56	62	68	74
0°	17,650 (28)	13,500 (32.3)	9,680 (38.3)	7,160 (44.3)	5,300 (50.3)	3,720 (56.3)	2,660 (62.3)	1,760 (68.3)

Stationary Capacity 360° Arc

Boom Angle	Main Boom Length in Feet				
	34	38	44	50	56
0°	8,310 (28)	5,975 (32.3)	3,910 (38.3)	2,370 (44.3)	1,235 (50.3)

Pick & Carry Capacities Up to 2.5 MPH Boom Centered (7) Over Front

Boom Angle	Main Boom Length in Feet							
	34	38	44	50	56	62	68	74
0°	17,650 (28)	11,600 (32.3)	8,820 (38.3)	6,780 (44.3)	5,160 (50.3)	3,650 (56.3)	2,610 (62.3)	1,680 (68.3)

9385

ON RUBBER 29.5 x 25 TIRES

Stationary Capacity Defined Arc (3) Over Front

Boom Angle	Main Boom Length in Feet								
	34	38	44	50	56	62	68	74	81
0°	18,350 (28)	13,600 (32.3)	9,930 (38.3)	7,320 (44.3)	5,455 (50.3)	3,990 (56.3)	2,780 (62.3)	1,950 (68.3)	1,080 (74.8)

Stationary Capacity 360° Arc

Boom Angle	Main Boom Length in Feet				
	34	38	44	50	56
0°	8,740 (28)	6,280 (32.3)	4,060 (38.3)	2,440 (44.3)	1,330 (50.3)

Pick & Carry Capacities Up to 2.5 MPH Boom Centered (7) Over Front

Boom Angle	Main Boom Length in Feet								
	34	38	44	50	56	62	68	74	81
0°	18,350 (28)	13,108 (32.3)	9,930 (38.3)	7,320 (44.3)	5,455 (50.3)	3,990 (56.3)	2,780 (62.3)	1,950 (68.3)	1,080 (74.8)

9390

**ON RUBBER 26.5 X 25-26PR TIRE
(STATIONARY-DEFINED ARC OVER FRONT)**

Radius in Feet	Main Boom Length in Feet									
	34	38	44	50	56	62	68	74	81	
10	55,810 (63.5)	38,700 (67)	29,800 (70.5)							
12	52,230 (60)	33,300 (63.5)	28,450 (67.5)							
15	46,000 (53.5)	27,100 (58.5)	27,100 (63.5)	27,100 (67)	27,100 (70)					
20	31,914 (42)	26,000 (49)	20,100 (55.5)	20,100 (60.5)	20,100 (64)	20,100 (67)				
25	21,400 (26)	21,400 (37.5)	19,400 (47)	15,400 (53.5)	15,400 (58)	15,400 (62)	15,400 (65)			
30		15,530 (21.5)	15,530 (37)	12,000 (46)	12,000 (52)	12,000 (56.5)	12,000 (60)	12,000 (63)		
35			11,580 (23.5)	11,500 (37)	9,500 (46)	9,500 (50.5)	9,500 (55)	9,500 (58.5)	9,500 (62)	
40				8,830 (25.5)	8,300 (37)	8,300 (44)	7,500 (49.5)	7,500 (53.5)	7,500 (58)	
45					6,910 (26.5)	6,910 (36.5)	6,700 (43.5)	5,900 (48.5)	5,900 (53.5)	
50						5,380 (8)	5,380 (27.5)	5,380 (36.5)	4,600 (43)	4,600 (48.5)
55							3,970 (13)	3,970 (28.5)	3,500 (36.5)	3,500 (43.5)
60								3,020 (16.5)	3,020 (29)	2,600 (37.5)
65									2,250 (19)	1,800 (31)
70										1,500 (22.5)

A6-829-009277

**ON RUBBER 29.5 X 25-22PR TIRE
(STATIONARY-DEFINED ARC OVER FRONT)**

Radius in Feet	Main Boom Length in Feet									
	34	38	44	50	56	62	68	74	81	
10	56,980 (63.5)									
12	55,200 (60)									
15	50,170 (53.5)									
20		33,400 (42)	27,000 (49)	22,000 (55.5)	22,000 (60.5)					
25		22,740 (26)	22,740 (37.5)	19,000 (47)	17,300 (53.5)	17,300 (58)				
30			15,970 (21.5)	15,970 (37)	13,600 (46)	13,600 (52)	13,600 (56.5)			
35				11,550 (23.5)	10,900 (37)	10,900 (45)	10,900 (50.5)	10,900 (55)		
40					9,120 (25.5)	8,800 (37)	8,800 (44)	8,800 (49.5)	8,800 (53.5)	8,800 (58)
45						7,060 (26.5)	7,060 (36.5)	7,060 (43.5)	7,060 (48.5)	7,060 (53.5)
50							5,520 (8)	5,520 (27.5)	5,520 (36.5)	5,520 (43.5)
55								4,280 (13)	4,280 (28.5)	4,280 (36.5)
60									3,210 (16.5)	3,210 (29)
65										2,360 (31)
70										1,700 (22.5)

A-829-009076

**ON RUBBER
(STATIONARY CAPACITIES - 360°)**

Radius in Feet	Main Boom Length in Feet						
	34	38	44	50	56	62	68
10	43,040 (63.5)	29,800 (67)	29,800 (70.5)				
12	37,470 (60)	25,000 (63.5)	25,000 (67.5)				
15	27,150 (53.5)	19,700 (58.5)	19,700 (63.5)	19,700 (67)	19,700 (70)		
20	16,470 (42)	16,470 (49)	13,800 (55.5)	13,800 (60.5)	13,800 (64)	13,800 (67)	
25	10,520 (26)	10,520 (37.5)	10,520 (47)	10,000 (53.5)	10,000 (58)	10,000 (62)	10,000 (65)
30		7,020 (21.5)	7,020 (37)	7,020 (46)	7,020 (52)	7,020 (56.5)	7,020 (60)
35			4,880 (23.5)	4,880 (37)	4,880 (45)	4,880 (50.5)	4,880 (55)
40				3,350 (25.5)	3,350 (37)	3,350 (44)	3,350 (49.5)
45					2,220 (26.5)	2,220 (36.5)	2,220 (43.5)
50						1,270 (8)	1,270 (27.5)

A-829-009278

**ON RUBBER
(STATIONARY CAPACITIES - 360°)**

Radius in Feet	Main Boom Length in Feet						
	34	38	44	50	56	62	68
10	46,400 (63.5)						
12	37,940 (60)						
15	27,080 (53.5)						
20	16,500 (42)	16,500 (49)	14,500 (55.5)	14,500 (60.5)			
25	11,050 (26)	11,050 (37.5)	11,050 (47)	10,100 (53.5)	10,100 (58)		
30		7,440 (21.5)	7,440 (37)	7,440 (46)	7,440 (52)	7,440 (56.5)	
35			5,160 (23.5)	5,160 (37)	5,160 (45)	5,160 (50.5)	5,160 (55)
40				3,610 (25.5)	3,610 (37)	3,610 (44)	3,610 (49.5)
45					2,290 (26.5)	2,290 (36.5)	2,290 (43.5)
50						1,370 (8)	1,370 (27.5)

A-829-009077

**PICK & CARRY CAPACITIES - (UP TO 2.5MPH)
BOOM CENTERED OVER FRONT**

Radius in Feet	Main Boom Length in Feet									
	34	38	44	50	56	62	68	74	81	
10	48,220 (63.5)	38,700 (67)	29,800 (70.5)							
12	42,060 (60)	33,300 (63.5)	28,450 (67.5)							
15	35,010 (53.5)	27,100 (58.5)	27,100 (63.5)	27,100 (67)	27,100 (70)					
20	30,320 (42)	20,100 (49)	20,100 (55.5)	20,100 (60.5)	20,100 (64)	20,100 (67)				
25	21,400 (26)	18,800 (37.5)	15,400 (47)	15,400 (53.5)	15,400 (58)	15,400 (62)	15,400 (65)	15,400 (67)		
30		15,530 (21.5)	12,000 (37)	12,000 (46)	12,000 (52)	12,000 (56.5)	12,000 (60)	12,000 (63)	12,000 (66)	
35			10,260 (23.5)	9,500 (37)	9,500 (45)	9,500 (50.5)	9,500 (55)	9,500 (58.5)	9,500 (62)	
40				8,150 (25.5)	7,500 (37)	7,500 (44)	7,500 (49.5)	7,500 (53.5)	7,500 (58)	
45					6,580 (26.5)	5,900 (36.5)	5,900 (43.5)	5,900 (48.5)	5,900 (53.5)	
50						5,230 (8)	4,600 (27.5)	4,600 (36.5)	4,600 (43)	4,600 (48.5)
55							3,900 (13)	3,500 (28.5)	3,500 (36.5)	3,500 (43.5)
60								2,970 (16.5)	2,600 (29)	2,600 (37.5)
65									2,200 (19)	1,800 (31)
70										1,170 (22.5)

A-829-009279

**PICK & CARRY CAPACITIES - (UP TO 2.5MPH)
BOOM CENTERED OVER FRONT**

Radius in Feet	Main Boom Length in Feet									
	34	38	44	50	56	62	68	74	81	
10	52,100 (63.5)									
12	45,410 (60)									
15	37,780 (53.5)									
20	30,540 (42)	27,000 (49)	22,200 (55.5)	22,200 (60.5)						
25	22,740 (26)	19,000 (37.5)	19,000 (47)	17,300 (53.5)	17,300 (58)					
30		15,970 (21.5)	13,600 (37)	13,600 (46)	13,600 (52)	13,600 (56.5)				
35			11,550 (23.5)	10,900 (37)	10,900 (45)	10,900 (50.5)	10,900 (55)			
40				9,120 (25.5)	8,800 (37)	8,800 (44)	8,800 (49.5)	8,800 (53.5)	8,800 (58)	
45					7,060 (26.5)	7,060 (36.5)	7,060 (43.5)	7,060 (48.5)	7,060 (53.5)	
50						5,520 (8)	5,520 (27.5)	5,520 (36.5)	5,520 (43)	5,520 (48.5)
55							4,280 (13)	4,280 (28.5)	4,280 (36.5)	4,280 (43.5)
60								3,210 (16.5)	3,210 (29)	3,210 (37.5)
65									2,360 (19)	2,360 (31)
70										1,700 (22.5)

A-829-009078